

EWELLIX

MAKERS IN MOTION

Profile rail guides - LLT catalogue



Contents

1 Introduction	4	4 Mounting instruction and maintenance	74
1.1 Product description.....	5	4.1 Design rules	75
1.2 Design	6	4.1.1 Typical mounting examples.....	75
1.2.1 Components and material specifications.....	7	4.1.2 Interface design, screw sizes and tightening torques	76
1.2.2 Standard carriage components	8	4.1.3 Position tolerances for attachment holes.....	77
1.3 Features and benefits	9	4.1.4 Permissible height deviation.....	78
1.4 Product range	10	4.1.5 Parallelism	79
1.4.1. Product overview	10	4.2 Mounting profile rail guides	80
1.4.2 Preferred range.....	11	4.2.1 Packaging (Shipment).....	80
2 Selection guide	14	4.2.2 Mounting the carriages	80
2.1 Technical data	15	4.2.3 Preparation	80
2.1.1 Load rating	15	4.2.4 Mounting the master rail.....	81
2.1.2 Preload classes.....	16	4.2.5 Parallel alignment of subsidiary rail	82
2.1.3 Accuracy	17	4.2.6 Mounting a retaining strip	84
2.1.4 Rigidity	18	4.2.7 Mounting jointed rails	84
2.1.5 Permissible operating conditions	19	4.2.8 Installing plastic caps.....	85
2.1.6 Friction.....	20	4.2.9 Installing metal plugs.....	85
2.1.7 Applications in corrosive environments.....	22	4.3 Mounting accessories	86
2.1.8 Jointed rail tracks.....	23	4.3.1 Mounting the scraper plate (S1).....	86
2.2 Calculation of bearing loads.....	24	4.3.2 Mounting an additional front seal (S7)	86
2.2.1 Calculation bases	24	4.3.3 Mounting the seal kit (S3).....	87
2.2.2 Constant mean load	26	4.3.4 Mounting the low friction shield (S0).....	87
2.2.3 Factors of influence	30	4.3.5 Mounting the LLT Lube element (S6)	88
2.2.4 Load conditions.....	31	4.3.6 Mounting an adapter plate (PL).....	89
2.2.5 Modified basic rating life	32	4.3.7 Mounting the grease nipple and lubrication connector (VN UA)	89
2.2.6 Linear guide calculation tools	33	4.3.8 Mounting the bellows	90
2.2.7 Legend	34	4.4 Maintenance and repairs	91
3 Product range	36	4.4.1 Preventative maintenance	91
3.1 Carriage data.....	37	4.4.2 Lubrication.....	91
3.1.1 Carriage LLTHC ... SA.....	38	4.4.3 Replacement	94
3.1.2 Carriage LLTHC ... A.....	40	4.5 Typical application areas	95
3.1.3 Carriage LLTHC ... LA	42	4.6 Customized solution	96
3.1.4 Carriage LLTHC ... SU	44	4.7 FAQ.....	97
3.1.5 Carriage LLTHC ... U	46	4.8 Ordering key.....	102
3.1.6 Carriage LLTHC ... LU	48	4.8.1 Ordering key system.....	102
3.1.7 Carriage LLTHC ... R.....	50	4.8.2 Ordering key carriages.....	103
3.1.8 Carriage LLTHC ... LR	52	4.8.3 Ordering key rails	104
3.2 Rail data	55	4.8.4 Ordering key accessories (delivered separately)..	104
3.2.1 LLTHR rails.....	56	4.8.5 Ordering key bellows.....	105
3.2.2 LLTHR rails ... D4 rails	58	5 Customer specification sheet	106
3.2.3 LLTHR ... D6 rails	60		
3.3 Accessories	62		
3.3.1 Scraper plate (S1)	64		
3.3.2 Additional front seal (S7)	65		
3.3.3 Seal kit (S3).....	66		
3.3.4 Low friction shield (S0)	67		
3.3.5 Lube element (S6)	68		
3.3.6 Adapter plate (PL).....	69		
3.3.7 Lubrication connectors	70		
3.3.8 Bellows	72		

The heritage of innovation

Ewellix is a global innovator and manufacturer of linear motion and actuation solutions used in assembly automation, medical applications and mobile machinery. Formerly part of SKF Group, the Ewellix Group consists of 16 sales units and eight factories. External net sales are approximately 2.3 SEK billion and we employ around 1200 people. Ewellix is headquartered in Gothenburg, Sweden and is owned by Triton.

Technology leadership

Our journey began **over 50 years** ago as part of the SKF Group, a leading global technology provider, with the world's first precision ball and roller screw factories. Our history with SKF provided us with the **expertise to continuously develop new technologies** and use them to create cutting edge products that offer our customers a competitive advantage.

In 2019, we became independent from SKF and changed our name to Ewellix. **We are proud of our heritage.** This gives us a unique foundation on which to build an agile business with engineering excellence and innovation as our core strengths.

Global presence and local support

With our **global presence**, we are uniquely positioned to deliver **standard components and custom-engineered solutions**, with full technical and applications support around the world. The long lasting relationships with our distributor partners allow us to support customers in a variety of different industries. At Ewellix, we don't just provide products; **we engineer integrated solutions** that help customers realise their ambitions.



1200 employees



16 sales units



8 factories

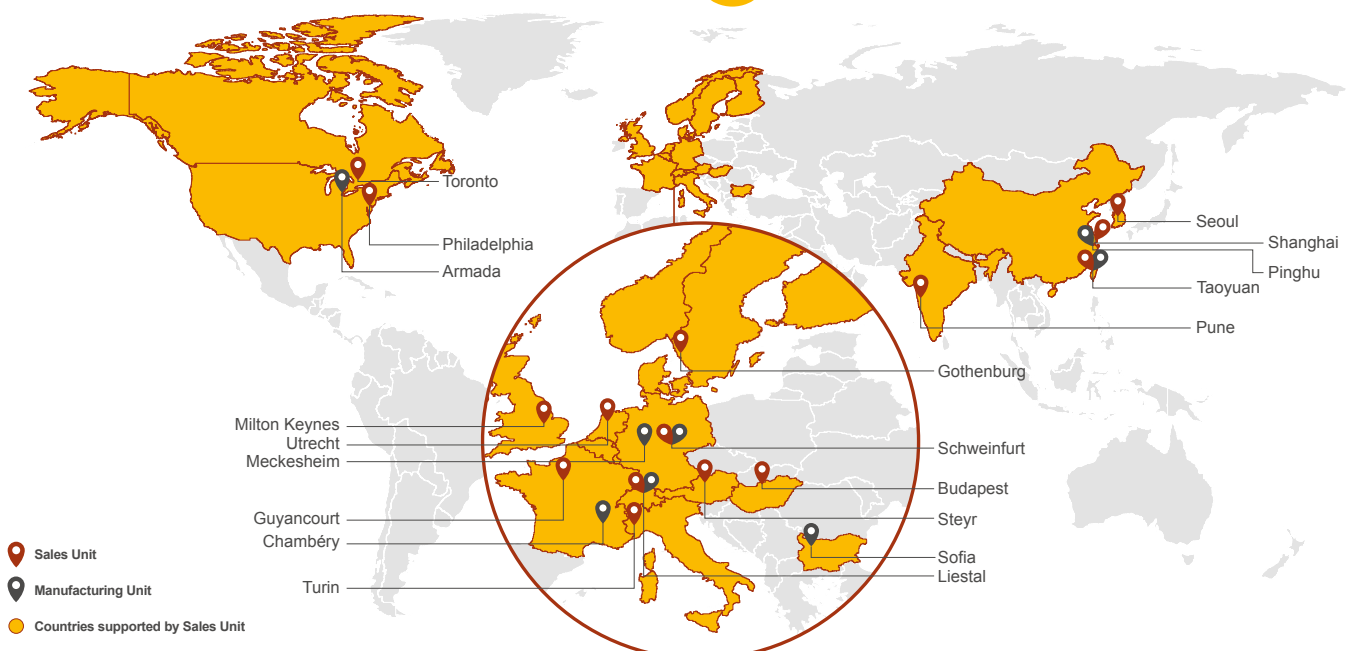

Trusted engineering expertise

Our industry is in motion; pushing towards solutions that reduce environmental impact and leverage new technology. We provide technical and manufacturing expertise to overcome our customers' challenges.

Engineering for the future

We work in a **wide range of industries**, where our solutions provide key functionality for business critical applications.

For the **medical industry**, we provide precision components for use in core medical equipment.

Our unparalleled understanding of **industrial automation** systems is based on decades of research into advanced automation components and techniques.

Our deep knowledge of **mobile machinery** provides powerful and reliable electromechanical solutions for the harshest conditions. In an **industrial distribution** setting, we supply linear expertise to our partners, empowering them to serve customers with greater efficiency.

We offer excellence

We have a **unique understanding of linear equipment** and how it's integrated in customers' applications to provide the best performance and machine efficiency.

We assist our customers by creating equipment that runs faster, longer and that is safe and sustainable.

We provide a wide variety of **linear motion components** and **electromechanical actuators** for equipping any automation application, thus helping our customers **reduce their footprint, energy use and maintenance**.

We push for lower energy consumption that **increase productivity and reduce the environmental impact**.

Actuation systems



Ball and roller screws



Linear guides and systems

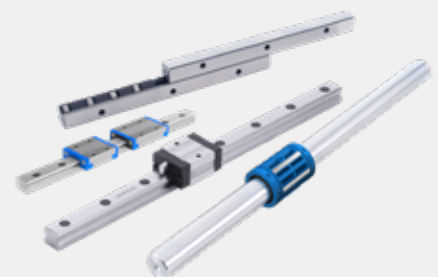

1

Introduction

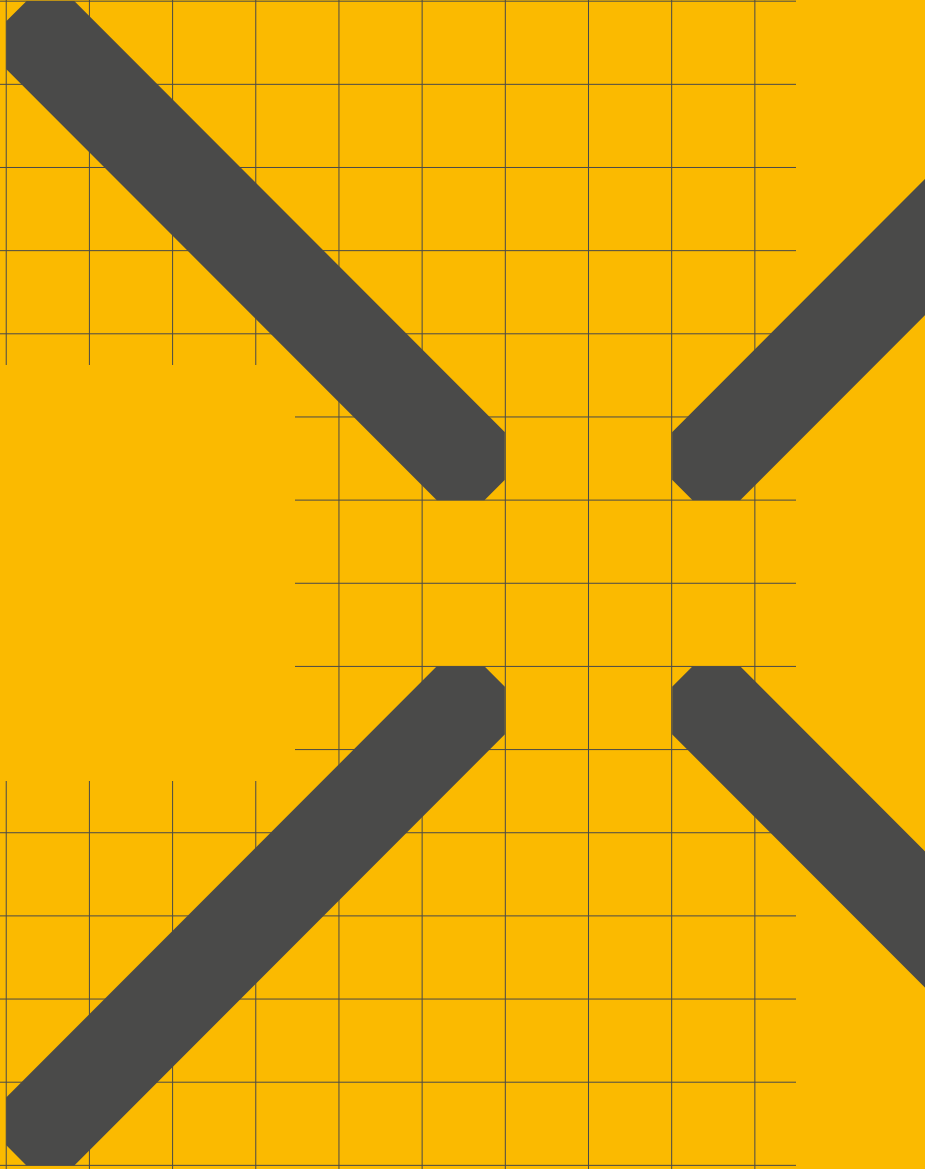

1.1 Product description

The productivity and economic success of a given application depends, to a large extent, on the quality of the selected linear components. Often these components determine market acceptance and thus help to obtain a competitive edge for the manufacturer. To do this, the linear components have to be as adaptable as possible to precisely meet the application's requirements, ideally with standard components.

The Ewellix profile rail guide series LLT satisfies these market demands: available in a wide range of sizes, carriages and accessories as well as in various preload and precision classes, LLT profile rail guides facilitate adaptation to individual application demands. In combination with their ability to operate at virtually unlimited stroke, this opens up almost any design option.

The range of possible applications include material handling, plastic injection moulding, woodworking, printing, packaging and medical devices, to name only a few. In these types of applications, the design of the LLT reveals its full capabilities.

Ewellix manufactures LLT profile rail guides in an X-arrangement with a 45° contact angle between the rolling elements and raceways. This design promotes equal load sharing in all four main load directions to provide greater design flexibility. Moreover, deviations in parallelism and height, which usually occur in multi-axis systems, can be compensated for more efficiently, resulting in reliable and smooth operation under a variety of operating conditions.

In addition, Ewellix offers a miniature profile rail guide series and a series of ready assembled and driven profile rail guide slides. Contact your Ewellix representative for additional information.



1.2 Design

Just as with rotary bearings, the raceways of profile rail guides can be arranged in an X- or O-configuration. The technical characteristics of these two arrangements are essentially the same. Therefore, there are no basic differences in behaviour in the vast majority of load situations, except when they are subjected to moment loads around the x-axis.

The Profile rail guides from Ewellix feature an X-arrangement, based on the contact angle of the rolling elements (\rightarrow fig. 1).

The advantage of this arrangement is that deviations in parallelism and height, which usually appear in multi-axes systems, can be accommodated more effectively (\rightarrow fig. 2).

Due to the design-related smaller lever arm, the X-arrangement provides better self-aligning capability.

In combination with a two-point contact of the rolling elements, running friction is kept to a minimum.

This results in a smooth and stick-slip-free operation of the guidance system.

Fig. 1

Schematic illustration of the different ball-arrangements



Fig. 2

Self-aligning capability in comparison

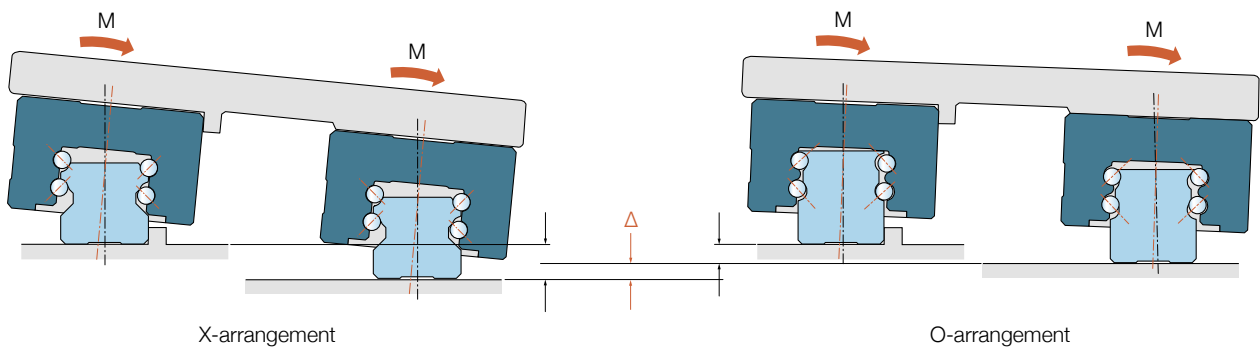

1.2.1 Components and material specifications

1

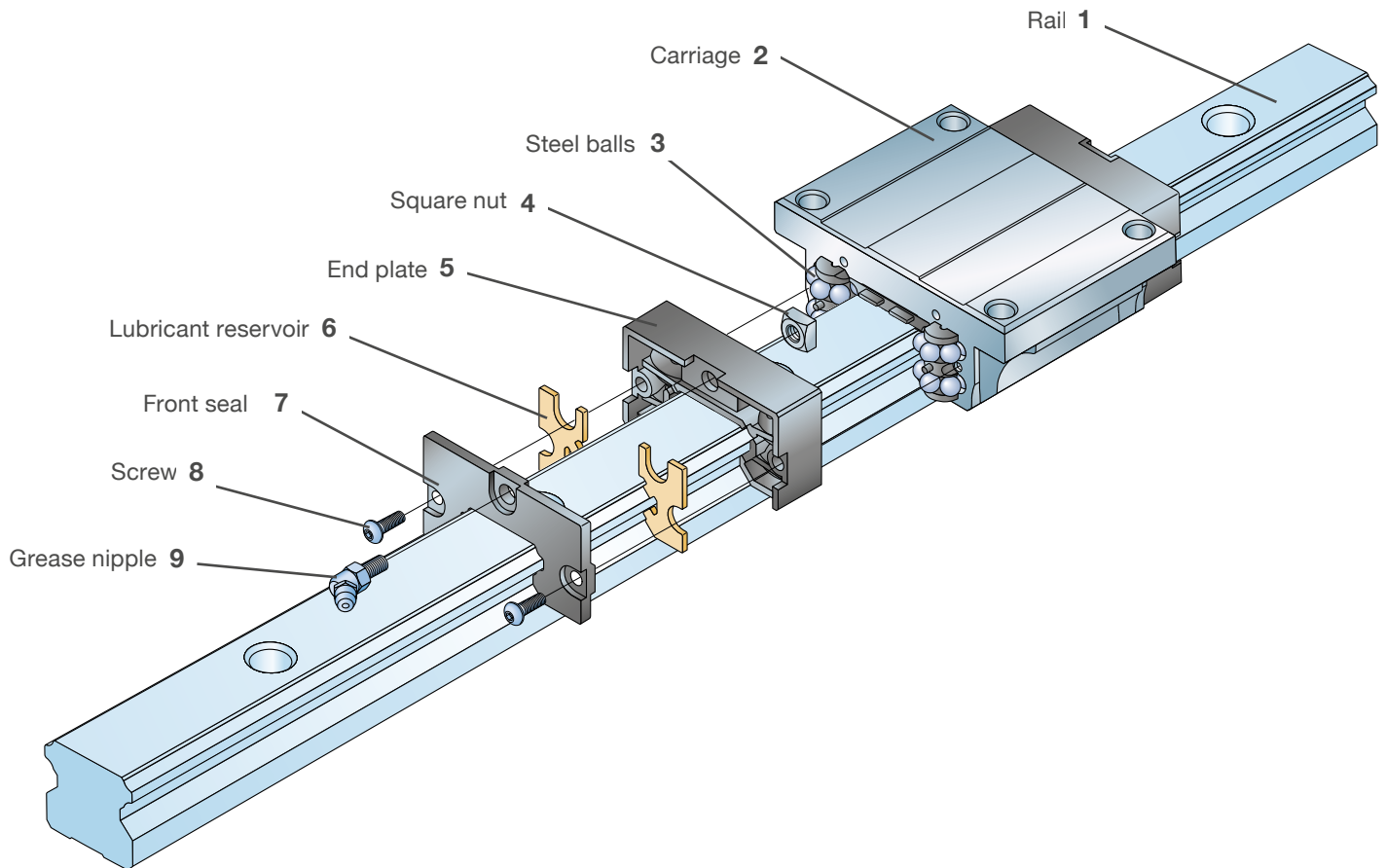

Material specifications

1. Steel, inductive hardened
2. Steel, case hardened
3. Bearing steel
4. Steel, zinc coated
5. POM, reinforced
6. EPU foam
7. PA 6.6 and Elastomer; alternative low friction S0 shield made from PA 6.6
8. Steel
9. Steel, nickel coated

1.2.2 Standard carriage components

Seals

The ingress of dirt, swarf and liquids, as well as lubricant leakage can significantly reduce the service life of a profile rail guide system. Ewellix LLT profile rail guide carriages are therefore supplied with front, side and inner seals as standard, which can significantly extend service life.

Front seal

Front seals are especially important since they provide protection for the carriage in the direction of movement. They are designed as double-lip seals in order to provide improved wiping properties (↳ fig. 3).

Side seal

Side seals effectively prevent contaminants from working environment into the system from below. Seal design can deviate based on size (↳ fig. 4).

Inner seal

Inner seals are an additional means of protection against lubricant leakage. Seal design can deviate based on size (↳ fig. 5).

Grease nipple

Two lube ports with metal thread are located on both front sides of each carriage. As standard, one grease nipple for manual relubrication is supplied along with the carriage, while the opposite side is secured by a set screw. The metal thread also enables the easy and reliable mounting of automatic lubricators.

Grease nipples are according to standard JIS 1575:2000 (↳ page 70).

If some accessories require longer grease nipples, they will be provided.

Fig. 3

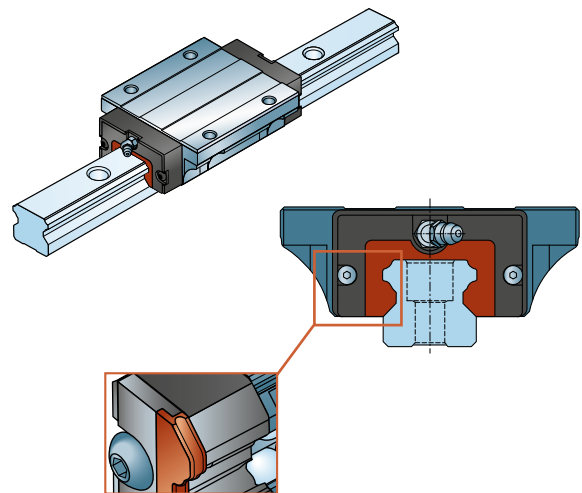

Fig.4

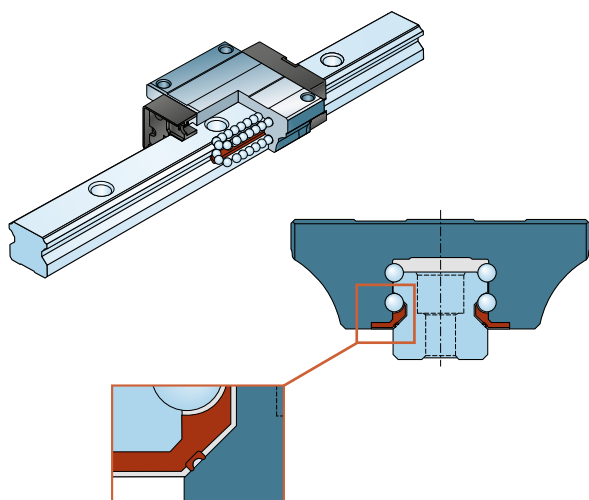
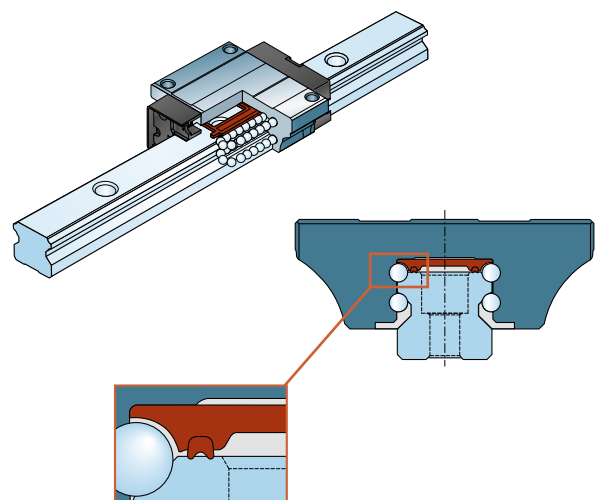
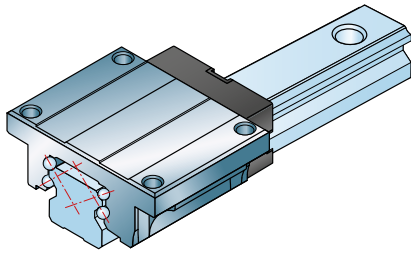

Fig. 5



1.3 Features and benefits



Improved running performance

The LLT profile rail guide has four rows of balls with a 45° contact angle between the rolling elements and raceways. This X-arrangement improves the system's self-aligning capability. Mounting deviations can be accommodated even under preload, resulting in smooth running performance. Friction is kept to a minimum due to two-point ball contact. This enables reliable, stick-slip-free operation for the life of the rail guide.

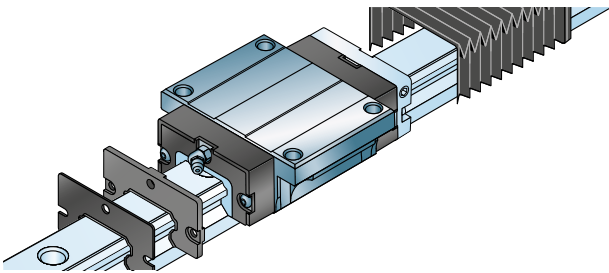

Modular concept for customized solutions

Applications have different speed, precision and environmental requirements. As a result, Ewellix LLT rail guides use modular components so that cost-effective solutions can be built based on the needs of the application. Various precision and preload classes are available to meet different precision and rigidity requirements. Furthermore, a wide range of accessories supports its adaptation to specific environmental needs.

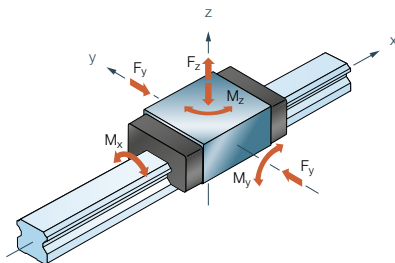

Rigidity, strength and precision for improved production processes

The four-row arrangement of balls at a 45° angle optimizes load sharing in all four main load directions and is in accordance with ISO 14728. This feature provides a high degree of design flexibility. The ability to accommodate high loads and moment loads makes these rail guides ideal even for single carriage systems.

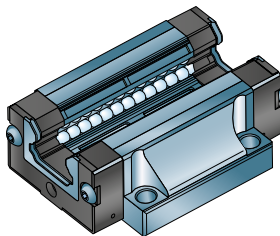

Longer service life and reduced maintenance

Ewellix profile rail guide carriages are pre-lubricated at the factory. The integrated lubricant reservoirs, located in the end plates, constantly relubricate the circulating balls. Both ends of the carriage have threaded metal lubrication ports to accommodate an automatic re-lubrication system. One grease nipple is provided as standard with each carriage. These fully sealed carriages have double lip seals on both ends as well as side and inner seals. The low-friction seals are highly effective against the ingress of contaminants.

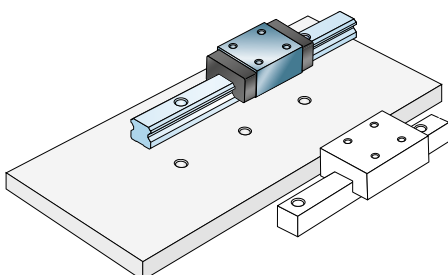

Interchangeability and global availability

The main dimensions of Ewellix profile rail guides are in accordance with ISO 12090-1. This enables dimensional interchangeability with all ISO-compliant brands. Ewellix's global sales and distribution network results in availability of replacement parts and serviceability for all systems worldwide.

1.4 Product range

1.4.1. Product overview

LLTHC ... SA

Flanged carriage, short length, standard height
Further information on **page 38**



LLTHC ... A

Flanged carriage, standard length, standard height.
Further information on **page 40**



LLTHC ... LA

Flanged carriage, extended length, standard height
Further information on **page 42**



LLTHC ... R

Slim-line carriage, standard length, extended height
Further information on **page 50**



LLTHR profile rail with blind holes
Additional information on **page 58**

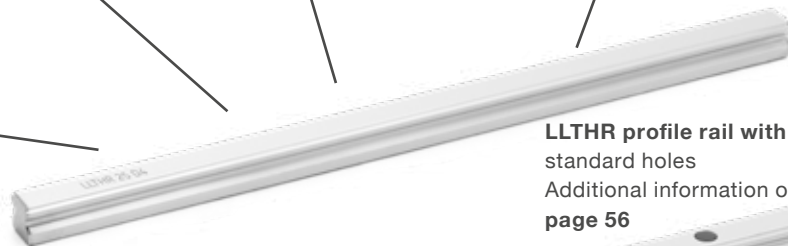

LLTHR profile rail with standard holes
Additional information on **page 56**



LLTHR profile rail with protective metal plugs
Additional information on **page 60**

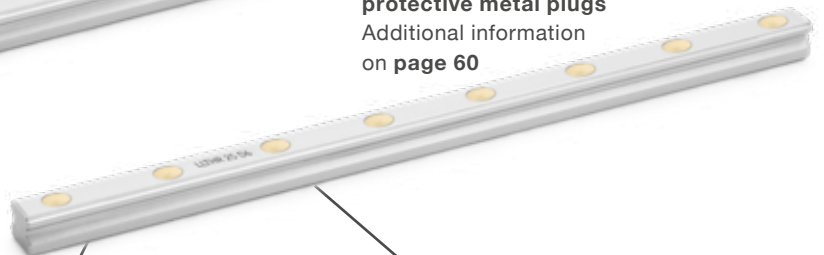

LLTHC ... LR

Slim-line carriage, extended length, extended height
Further information on **page 52**



LLTHC ... SU

Slim-line carriage, short length, standard height
Further information on **page 44**



LLTHC ... U

Slim-line carriage, standard length, standard height
Further information on **page 46**



LLTHC ... LU

Slim-line carriage, extended length, standard height
Further information on **page 48**



1.4.2 Preferred range

Carriages

Table 1

Size	Precision class	Designation		
		Preload class		
		T0	T1	T2
15	P5	LLTHC 15 SA T0 P5	LLTHC 15 SA T1 P5	–
		LLTHC 15 A T0 P5	LLTHC 15 A T1 P5	LLTHC 15 A T2 P5
		LLTHC 15 SU T0 P5	LLTHC 15 SU T1 P5	–
		LLTHC 15 U T0 P5	LLTHC 15 U T1 P5	LLTHC 15 U T2 P5
		LLTHC 15 R T0 P5	LLTHC 15 R T1 P5	LLTHC 15 R T2 P5
		LLTHC 15 SA T0 P3	LLTHC 15 SA T1 P3	–
	P3	LLTHC 15 A T0 P3	LLTHC 15 A T1 P3	–
		LLTHC 15 SU T0 P3	LLTHC 15 SU T1 P3	–
		LLTHC 15 U T0 P3	LLTHC 15 U T1 P3	–
		LLTHC 15 R T0 P3	LLTHC 15 R T1 P3	–
		LLTHC 20 SA T0 P5	LLTHC 20 SA T1 P5	–
		LLTHC 20 A T0 P5	LLTHC 20 A T1 P5	LLTHC 20 A T2 P5
		LLTHC 20 LA T0 P5	LLTHC 20 LA T1 P5	LLTHC 20 LA T2 P5
		LLTHC 20 SU T0 P5	LLTHC 20 SU T1 P5	–
LLTHC 20 U T0 P5	LLTHC 20 U T1 P5	LLTHC 20 U T2 P5		
LLTHC 20 LR T0 P5	LLTHC 20 LR T1 P5	LLTHC 20 LR T2 P5		
P3	LLTHC 20 SA T0 P3	LLTHC 20 SA T1 P3	–	
	LLTHC 20 A T0 P3	LLTHC 20 A T1 P3	–	
	LLTHC 20 LA T0 P3	LLTHC 20 LA T1 P3	–	
	LLTHC 20 SU T0 P3	LLTHC 20 SU T1 P3	–	
	LLTHC 20 U T0 P3	LLTHC 20 U T1 P3	–	
	LLTHC 20 LR T0 P3	LLTHC 20 LR T1 P3	–	
	LLTHC 25 SA T0 P5	LLTHC 25 SA T1 P5	–	
	LLTHC 25 A T0 P5	LLTHC 25 A T1 P5	LLTHC 25 A T2 P5	
LLTHC 25 LA T0 P5	LLTHC 25 LA T1 P5	LLTHC 25 LA T2 P5		
LLTHC 25 SU T0 P5	LLTHC 25 SU T1 P5	–		
LLTHC 25 U T0 P5	LLTHC 25 U T1 P5	LLTHC 25 U T2 P5		
LLTHC 25 LU T0 P5	LLTHC 25 LU T1 P5	LLTHC 25 LU T2 P5		
LLTHC 25 R T0 P5	LLTHC 25 R T1 P5	LLTHC 25 R T2 P5		
LLTHC 25 LR T0 P5	LLTHC 25 LR T1 P5	LLTHC 25 LR T2 P5		
P3	LLTHC 25 SA T0 P3	LLTHC 25 SA T1 P3	–	
	LLTHC 25 A T0 P3	LLTHC 25 A T1 P3	–	
	LLTHC 25 LA T0 P3	LLTHC 25 LA T1 P3	–	
	LLTHC 25 SU T0 P3	LLTHC 25 SU T1 P3	–	
	LLTHC 25 U T0 P3	LLTHC 25 U T1 P3	–	
	LLTHC 25 LU T0 P3	LLTHC 25 LU T1 P3	–	
	LLTHC 25 R T0 P3	LLTHC 25 R T1 P3	–	
	LLTHC 25 LR T0 P3	LLTHC 25 LR T1 P3	–	

Table 1

Size	Precision class	Designation				
		Preload class				
		T0	T1	T2		
30	P5	LLTHC 30 SA T0 P5	LLTHC 30 SA T1 P5	–		
		LLTHC 30 A T0 P5	LLTHC 30 A T1 P5	LLTHC 30 A T2 P5		
		LLTHC 30 LA T0 P5	LLTHC 30 LA T1 P5	LLTHC 30 LA T2 P5		
		LLTHC 30 SU T0 P5	LLTHC 30 SU T1 P5	–		
		LLTHC 30 U T0 P5	LLTHC 30 U T1 P5	LLTHC 30 U T2 P5		
		LLTHC 30 LU T0 P5	LLTHC 30 LU T1 P5	LLTHC 30 LU T2 P5		
		LLTHC 30 R T0 P5	LLTHC 30 R T1 P5	LLTHC 30 R T2 P5		
		LLTHC 30 LR T0 P5	LLTHC 30 LR T1 P5	LLTHC 30 LR T2 P5		
		P3	LLTHC 30 SA T0 P3	LLTHC 30 SA T1 P3	–	
			LLTHC 30 A T0 P3	LLTHC 30 A T1 P3	–	
	LLTHC 30 LA T0 P3		LLTHC 30 LA T1 P3	–		
	LLTHC 30 SU T0 P3		LLTHC 30 SU T1 P3	–		
	LLTHC 30 U T0 P3		LLTHC 30 U T1 P3	–		
	LLTHC 30 LU T0 P3		LLTHC 30 LU T1 P3	–		
	LLTHC 30 R T0 P3		LLTHC 30 R T1 P3	–		
	LLTHC 30 LR T0 P3		LLTHC 30 LR T1 P3	–		
	35		P5	LLTHC 35 SA T0 P5	LLTHC 35 SA T1 P5	–
				LLTHC 35 A T0 P5	LLTHC 35 A T1 P5	LLTHC 35 A T2 P5
		LLTHC 35 LA T0 P5		LLTHC 35 LA T1 P5	LLTHC 35 LA T2 P5	
		LLTHC 35 SU T0 P5		LLTHC 35 SU T1 P5	–	
LLTHC 35 U T0 P5		LLTHC 35 U T1 P5		LLTHC 35 U T2 P5		
LLTHC 35 LU T0 P5		LLTHC 35 LU T1 P5		LLTHC 35 LU T2 P5		
LLTHC 35 R T0 P5		LLTHC 35 R T1 P5		LLTHC 35 R T2 P5		
LLTHC 35 LR T0 P5		LLTHC 35 LR T1 P5		LLTHC 35 LR T2 P5		
P3		LLTHC 35 SA T0 P3		–	–	
		LLTHC 35 A T0 P3		–	–	
		LLTHC 35 LA T0 P3	–	–		
		LLTHC 35 SU T0 P3	–	–		
		LLTHC 35 U T0 P3	–	–		
		LLTHC 35 LU T0 P3	–	–		
		LLTHC 35 R T0 P3	–	–		
		LLTHC 35 LR T0 P3	–	–		
		45	P5	LLTHC 45 A T0 P5	LLTHC 45 A T1 P5	LLTHC 45 A T2 P5
				LLTHC 45 LA T0 P5	LLTHC 45 LA T1 P5	LLTHC 45 LA T2 P5
LLTHC 45 U T0 P5				LLTHC 45 U T1 P5	LLTHC 45 U T2 P5	
LLTHC 45 LU T0 P5				LLTHC 45 LU T1 P5	LLTHC 45 LU T2 P5	
LLTHC 45 R T0 P5	LLTHC 45 R T1 P5			LLTHC 45 R T2 P5		
LLTHC 45 LR T0 P5	LLTHC 45 LR T1 P5			LLTHC 45 LR T2 P5		
P3	LLTHC 45 A T0 P3			LLTHC 45 A T1 P3	–	
	LLTHC 45 LA T0 P3		LLTHC 45 LA T1 P3	–		
	LLTHC 45 U T0 P3		LLTHC 45 U T1 P3	–		
	LLTHC 45 LU T0 P3		LLTHC 45 LU T1 P3	–		
	LLTHC 45 R T0 P3		LLTHC 45 R T1 P3	–		
	LLTHC 45 LR T0 P3		LLTHC 45 LR T1 P3	–		

Rails

Table 2

Size	Precision class	Designation	
		One-piece-rail	Multi-piece-rail
15	P5	LLTHR 15-...P5	LLTHR 15-...P5 A
		LLTHR 15-...P5 D4	LLTHR 15-...P5 A D4
	P3	LLTHR 15-...P3	LLTHR 15-...P3 A
		LLTHR 15-...P3 D4	LLTHR 15-...P3 A D4
20	P5	LLTHR 20-...P5	LLTHR 20-...P5 A
		LLTHR 20-...P5 D4	LLTHR 20-...P5 A D4
	P3	LLTHR 20-...P3	LLTHR 20-...P3 A
		LLTHR 20-...P3 D4	LLTHR 20-...P3 A D4
25	P5	LLTHR 25-...P5	LLTHR 25-...P5 A
		LLTHR 25-...P5 D4	LLTHR 25-...P5 A D4
		LLTHR 25-...P5 D6	LLTHR 25-...P5 A D6
	P3	LLTHR 25-...P3	LLTHR 25-...P3 A
		LLTHR 25-...P3 D4	LLTHR 25-...P3 A D4
		LLTHR 25-...P3 D6	LLTHR 25-...P3 A D6
30	P5	LLTHR 30-...P5	LLTHR 30-...P5 A
		LLTHR 30-...P5 D4	LLTHR 30-...P5 A D4
		LLTHR 30-...P5 D6	LLTHR 30-...P5 A D6
	P3	LLTHR 30-...P3	LLTHR 30-...P3 A
		LLTHR 30-...P3 D4	LLTHR 30-...P3 A D4
		LLTHR 30-...P3 D6	LLTHR 30-...P3 A D6
35	P5	LLTHR 35-...P5	LLTHR 35-...P5 A
		LLTHR 35-...P5 D4	LLTHR 35-...P5 A D4
		LLTHR 35-...P5 D6	LLTHR 35-...P5 A D6
	P3	LLTHR 35-...P3	LLTHR 35-...P3 A
		LLTHR 35-...P3 D4	LLTHR 35-...P3 A D4
		LLTHR 35-...P3 D6	LLTHR 35-...P3 A D6
45	P5	LLTHR 45-...P5	LLTHR 45-...P5 A
		LLTHR 45-...P5 D4	LLTHR 45-...P5 A D4
		LLTHR 45-...P5 D6	LLTHR 45-...P5 A D6
	P3	LLTHR 45-...P3	LLTHR 45-...P3 A
		LLTHR 45-...P3 D4	LLTHR 45-...P3 A D4
		LLTHR 45-...P3 D6	LLTHR 45-...P3 A D6

2

Selection guide



2.1 Technical data

2.1.1 Load rating

Definition of the basic dynamic load rating C

The basic dynamic load rating C is the radial load, constant in magnitude and direction, which a linear rolling bearing can theoretically accommodate for a basic rating life represented by a travelled distance of 100 km (according to ISO 14728 Part 1).

NOTE: As per ISO 14728 Part 1, it is also permissible to state a reference distance of 50 km travelled. In this case, a conversion factor of 1,26 should be applied in order to enable proper comparison of the two load rating values (↳ **formula 1**).

$$(1) \quad C_{100} = \frac{C_{50}}{1,26}$$

Definition of the basic static load rating C₀

The basic static load rating C₀ is the static load in the direction of loading which corresponds to a calculated stress at the centre of the most heavily loaded contact point between the rolling element and each of the raceways of carriage and rail.

NOTE: This stress produces a permanent total deformation of the rolling element and the raceway which corresponds to about 0,0001 times the rolling element diameter (according to ISO 14728 Part 2).

Verification and validation

The load ratings stated in this catalogue have been calculated for all product types based on the standards cited.

The calculation model prescribed in the standards has been complemented and verified by Ewellix through internal simulations.

Since it is not economically feasible to test the load ratings of all catalogue types in practice, Ewellix carries out standardized durability examinations at regular intervals by means of selected reference sizes. These tests provide statistical evidence and documentation that the theoretically ascertained load ratings are valid under standardized practical test conditions.

In many cases, this Ewellix internal validation process saves the customer intensive field tests and offers high reliability for LLT profile rail guide designs.

Only in cases where the operating conditions are not known, as well as in cases where these conditions are more exacting than usual, customers are advised to conduct further field tests.

In practice, it is a common approach to integrate results and experiences of existing and proven designs in new designs and apply them to new applications. When using LLT profile rail guides, it also makes sense for customers to build on previous application experience in the continuous development of their applications.

2.1.2 Preload classes

To adjust a profile rail guide to the specific requirements of a given application, it is advisable to choose an appropriate preload. Preload can enhance the performance of an entire linear guidance system and increase the rigidity of the carriage under load .

Preload is determined by oversizing between steel balls and raceways on carriage and rail track. This is ensured by state-of-the-art, high-precision grinding processes carefully matched with rolling elements.

LLT ball profile rail guides are available in three different preload classes, as shown in **table 1**.

NOTE: The principle of the preload generation is shown in **fig. 1**.

For information about what preload classes are typically applied to different applications, see chapter **4.5 Typical application areas** (↳ page 95).

Fig. 1

Generation of preload

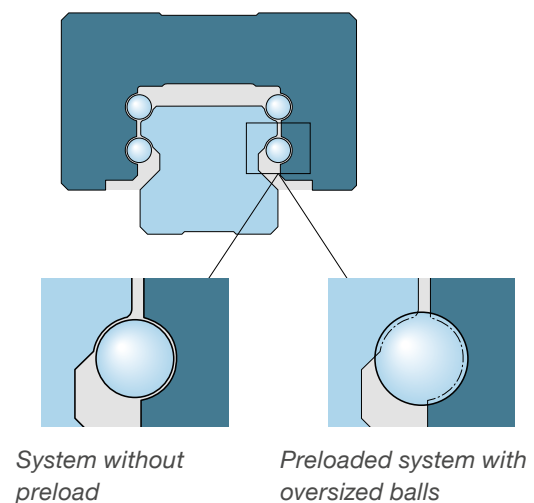

Table 1

Determining preload values according to preload class	
Preload class	Preload force F_{Pr}
T0	Zero to light preload For extremely smooth-running profile rail guide systems requiring low friction. This preload class is only available in P5 and P3 precision classes.
T1	$F_{Pr} = 2 \% \text{ of } C$ For precise profile rail guide systems with low and medium external loads and a high degree of rigidity.
T2	$F_{Pr} = 8 \% \text{ of } C$ For precise profile rail guide systems with high external load and high requirements for overall rigidity. Also recommended for single-rail systems. Additional common moment loads are absorbed without any significant elastic deformation.

2.1.3 Accuracy

Precision classes

Ewellix manufactures its LLT ball profile rail guides in three precision classes. These precision classes define the maximum tolerance range of a profile rail system in terms of height, width and parallelism. This choice determines the running accuracy of the system within the application (↳ **table 2** and chapter ↳ **4.5 Typical application areas**, page 95, for further information).

Width and height precision

The tolerance of width N determines the maximum deviation of the distance from the carriage to the rail in lateral direction. Both sides of the rail and the ground side of the carriage can be used as the reference side.

The tolerance of height H is measured between the mounting surface of the carriage and the ground bottom face of the rail. H and N are arithmetic mean values.

The deviations ΔH and ΔN result, when different carriages are measured on the same rail position.

Running parallelism

This refers to the running parallelism tolerance between the two reference planes of the rail and carriage when the carriage is moved along the entire rail length, the rail being screwed to the reference plane. Please refer to **diagram 1** for detailed information.

Combination of rails and carriages

All carriages and rails of the same size and precision class (P5/P3) can be combined with each other while maintaining the initial precision class. They are fully interchangeable. Mixed precision classes are possible.

NOTE: The lower accuracy can be guaranteed when system item assembled by rail and carriage with different accuracy.

NOTE: Precision class P1 can only be delivered as a complete system.

NOTE: Preload/Precision class T2 P3 can only be delivered as a complete system.

Table 2

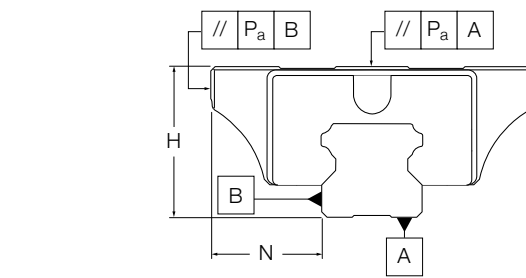

Precision class	Tolerances		Differences in dimension H and N on one rail	
	H ¹⁾	N	ΔH ¹⁾ max.	ΔN max.
-	μm		μm	
P5	± 100	± 40	30	30
P3	± 40	± 20	15	15
P1	± 20	± 10	7	7

¹⁾ Measured at the centre of the carriage

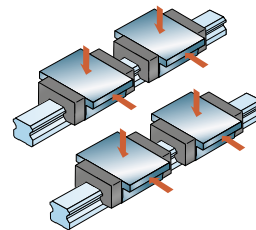

For any combination of carriages and rails

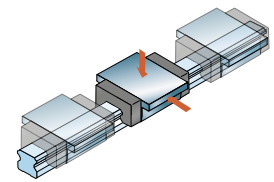

For different carriages on the same rail position

Diagram 1

Running parallelism

P_a Deviation in parallelism [μm] for N and H

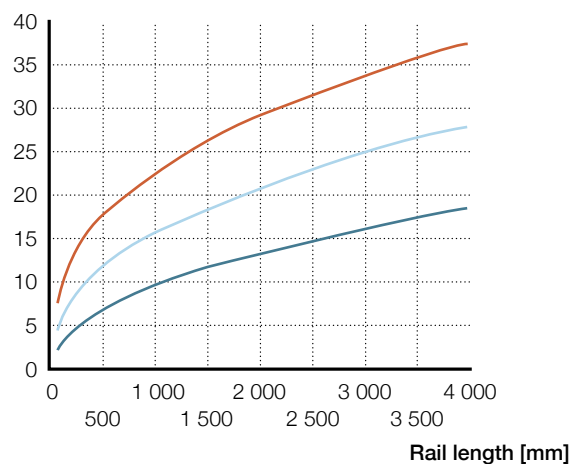

P5 = Standard

P1 = High

P3 = Medium

2.1.4 Rigidity

The rigidity of LLT profile rail guides, in addition to their load carrying capacity, is one of the most important criteria in product selection.

Rigidity can be defined as the deformation characteristics of a guidance system under external load. The rigidity of a system depends on the magnitude and direction of the external load, the type of guidance system (size, carriage type, preload) and the mechanical properties of the adjacent support structure. Usually, this load is indicated, including magnitude and direction, on the point of load application of the mounted guidance system.

Rigidity values, which only take deflection of the rolling elements into consideration, can deviate considerably under realistic conditions due to the elasticity of the support structure, the screw connections and the joints between components. Therefore, the overall rigidity at the bearing point is, as a rule, lower than that of the actual guidance system.

The different sizes and types of LLT profile rail guides feature significant differences in their deformation behaviour.

The diagrams represent only the deformation values for a single reference size. These values are measured on properly mounted LLTHS 25 rail guides bolted to well-prepared support surfaces. The loads were applied symmetrically between the load carrying raceways.

Rigidity values for other types of LLT profile rail guides are available on request.

Furthermore, the type and size of the carriage has an impact on rigidity due to the geometrical differences.

Diagram 2 shows the deformation behaviour of an LLT profile rail guide based on the selected carriage type in one load direction. It represents the behaviour of eight different size 25 carriage types under vertical pushing load in an identical mounting situation.

Diagram 2

Deformation behaviour of size 25 under vertical pushing load, with 8 type different carriages

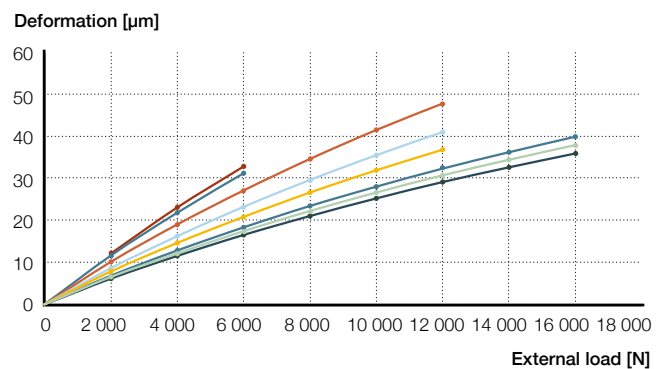

2.1.5 Permissible operating conditions

The function of LLT profile rail guides can be realized only if there are no deviations from the specified operating conditions. The formulae and life values stated in the chapter **2.2 Calculation of bearing loads** (→ page 24) are valid only if the operating conditions described in the following are met.

1.1.1 Permissible speed and acceleration

LLT profile rail guides can reach a maximum speed of

$$v_{\max} = 5 \text{ m/s.}$$

The maximum acceleration is

$$a_{\max} = 75 \text{ m/s}^2 \text{ (for preloaded systems).}$$

Permissible maximum load

When selecting an LLT profile rail guide, the dynamic and static load ratings are key factors in this process.

For example, the equivalent dynamic mean load during operation must not exceed 50 % of the dynamic load rating. To calculate the dynamic bearing load, see **page 26**.

Exceeding the dynamic load ratings in operation results in a deviation of the usual load distribution, and can significantly reduce bearing service life. A statistical evaluation according to Weibull is not reliable in these cases.

As stated in ISO 14728 Part 2, the maximum load should not exceed 50 % of the static load rating.

Required minimum load

To prevent the balls from sliding in the load zone during operation at higher speed, the carriage must be under a minimum load at all times. A value of about 2 % of the dynamic load rating can be used as a guideline. This is particularly important for applications that are characterized by highly dynamic cycles. LLT profile rail guides in the T1 preload class are typically able to satisfy minimum load requirements.

Permissible operating temperatures

The permissible temperature range for LLT profile rail guides is:

Continuous operation: −20 to +80 °C

Short-term: max. 100 °C

This temperature range is determined by the synthetic materials used for the ball retainers, recirculation devices and seals.

The time limit for the permissible maximum temperature is dependent on the actual operating conditions.

Low speed (< 0,2 m/s), slightly loaded (P < 15 % C) or stationary applications can be exposed to an ambient temperature < 100 °C for up to one hour.

Design measures like heat shielding can extend this period.

Be sure to check that the temperature limits of the lubricant can withstand elevated temperatures prior to use.

Standstill operation

When external forces create vibrations in a stationary LLT profile rail guide, surface damage due to micro-movements between the balls and raceways may occur. This can increase noise levels during dynamic operation and reduce system service life.

To avoid this type of damage, the guides should be isolated from external vibration and mechanically unloaded for transport purposes.

2.1.6 Friction

In addition to the external operating load, the friction in a guidance system is determined by a number of other factors. For example, the preload class, external loads, speed of travel and viscosity of the lubricant should be taken into consideration.

The displacement resistance is determined by the proportions of rolling and sliding friction generated by the rolling elements in the contact zone. Also, the recirculation geometry as well as the lubricant have an influence.

The effect of the lubricant depends on its characteristics, quantity and condition.

A running-in phase provides a better distribution of the lubricant in the carriage, and therefore reduces friction.

The operating temperature of the guidance system also influences friction. Higher temperatures reduce the viscosity of the lubricant.

Another factor is the sliding friction of the front and longitudinal seals in contact with the profile rail guide. The friction generated by the seals will, however, decrease after the running-in phase.

The friction can be reduced to a minimum when carriages with low friction shields S0 from size 15 to 30 are used. Due to the reduced sealing ability of these shields, these carriages should only be considered for applications in clean environments.

Moreover, the mounting precision of the rails relative to each other plays an important part, just like the flatness of the saddle plates as well as attachment structure for rail tracks connected to the guides.

The coefficient of friction for lubricated profile rail guides is typically between $\mu = 0,003$ and $0,005$. Lower values should be selected for higher loads, and higher values for lower loads. The friction values of the seals must be added to these values.

Table 3

Standard seal			Greased (Grease type LGEP2)		
Test condition			Standard seal + side seal + inner seal		
Designation	Size	Carriage length	LLTHS XX TX PX		
-			Running friction force standard (N) Max.		
			T0	T1	T2
Friction Force	15	Short	≤ 4,5	≤ 5,5	-
		Normal	≤ 5,5	≤ 6,5	≤ 8,5
	20	Short	≤ 9,5	≤ 10,5	-
		Normal	≤ 10,5	≤ 11,5	≤ 14,0
		Long	≤ 11,5	≤ 12,5	≤ 15,0
	25	Short	≤ 12,5	≤ 13,5	-
		Normal	≤ 13,5	≤ 14,5	≤ 17,0
		Long	≤ 14,5	≤ 15,5	≤ 18,0
	30	Short	≤ 14,5	≤ 15,5	-
		Normal	≤ 16,0	≤ 17,5	≤ 22,5
		Long	≤ 16,5	≤ 18,0	≤ 23,0
	35	Short	≤ 17,5	≤ 19,0	-
		Normal	≤ 19,0	≤ 20,5	≤ 26,5
		Long	≤ 20,0	≤ 21,5	≤ 27,5
	45	Normal	≤ 22,0	≤ 23,5	≤ 30,5
		Long	≤ 26,0	≤ 28,0	≤ 35,5

Table 4

Low friction shields S0			Without greasing		
Test condition			Low friction shields S0 + Side seal + inner seal		
Designation	Size	Carriage length	LLTHS XX TX PX		
			Running friction force standard (N) Max.		
-			T0	T1	T2
Friction Force	15	Short	≤ 1,2	≤ 1,5	-
		Normal	≤ 1,5	≤ 1,8	≤ 2,3
	20	Short	≤ 1,7	≤ 2,0	-
		Normal	≤ 2,0	≤ 2,3	≤ 3,1
		Long	≤ 2,5	≤ 2,8	≤ 3,6
	25	Short	≤ 2,0	≤ 2,4	-
		Normal	≤ 2,4	≤ 2,8	≤ 3,8
		Long	≤ 3,0	≤ 3,4	≤ 4,4
	30	Short	≤ 2,5	≤ 3,0	-
		Normal	≤ 3,0	≤ 3,5	≤ 4,8
		Long	≤ 3,5	≤ 4,0	≤ 5,3

Table 5

Additional friction force			Without greasing	
Test condition			Side seal + inner seal	
Size	Additional friction force base on standard seal (N)		S6 S6 kit on one side	S3 S3 kit on one side
	S1 S1 kit on one side	S7 S7 kit on one side		
15	0	1	1,02	4
20	0	1,25	1,02	4
25	0	1,5	2,04	4
30	0	1,75	3,06	4
35	0	2	4,08	4
45	0	2,25	-	4

NOTE:

1. Calculation example: LLTH 15 U T0 carriage standard push and pull force specification is less than or equal to 5.5N, S7 single-plate friction force will increased 1N, so after the S7 single-plate is installed on one side, the push and pull force specification will be less than or equal to 6.5N (5.5N + 1N); after the S7 single-plate is installed on both sides, the push and pull force specification is less than or equal to 7.5N (5.5N+1N*2)



2.1.7 Applications in corrosive environments

To ensure that LLT profile rail guides operate reliably in corrosive environments, the carriages and rails must be protected with special coatings. These coatings bring about substantial improvements in corrosion resistance and thus increase the wear resistance under critical operating conditions.

Ewellix protects components with the following coatings:

LLTHR rails: TDC (Thin Dense Chrome) coating

LLTHC carriages: Nickel layer

Rail: The rail features a very thin TDC layer that provides effective corrosion protection, but does not affect the load rating of the system. For technical data regarding both types of coatings, please refer to **table 6**.

This product range enables two combinations. The coated rail can be combined with both nickel-plated and standard carriages. A combination of coated rail and standard carriage can be used where the rails are exposed to slightly corrosive media only and the carriages are sufficiently shielded through the adjacent structure or other measures (e.g. machines during transport, installations in contact with weak cleaning solutions).

When used in combination with standard carriages, the catalogue load ratings can be used for the life calculation without change. For this design variant, users should bear in mind that preload increases slightly due to the layer thickness.

When using coated rails in combination with nickel-plated carriages, the load ratings for dynamic loads and moments will be reduced by 30 % and for static loads and moments by 20 %. The preload class T1 is available as standard. Systems with coated rails can have a slightly higher preload and friction. This will be partly eliminated after a short running time.

Availability

- Rail sizes: 15–45
- Coated rails: maximum length of about 4 000 mm
- Cut-to-length rail: standard – cut edges not coated
- Cut-to-length rail: possible – cut edges TDC coated

NOTE: Where coated LLT rails are used, glossy areas may appear on the raceways after running-in. The corrosion protection properties are not compromised. Coated rails are not completely covered with a complete layer of Thin Dense Chrome at the non-machined bottom rail area and inside the mounting holes. Due to the coating process, the matt grey color might appear in different shades at the rail bottom side.

Table 6

Technical data and ordering designations of coated components		
Properties	Rail	Carriage
Designation	LLTHR ... HD (Europe) LLTHR ... HA (USA/CAN)	LLTHC ... A HN LLTHC ... R HN LLTHC ... U HN
Coating	TDC	Nickel
Colour	matt grey	glossy silver
Layer hardness	900 HV – 1300 HV	550 HV - 800 HV
Corrosion protection	72 h (salt spray test DIN EN ISO 9227)	72 h (salt spray test DIN EN ISO 9227)
RoHS compliant	yes	yes
Stainless steel ball		Material no. 1.4125 (X105CrMo17)

Table 7

Available coated carriages	
Size	Type ¹⁾
15	A, R, SU, U
20	A, LA, U
25	A, LA, R, SU, U
30	A, LR, R, U
35	A, R, SU, U
45	A, R, U

¹⁾ Other type are available on request.

All components are delivered with preservative ex works. The nickel-plated carriages are delivered unlubricated and must be greased by the customer prior to use and re-lubricated at regular intervals.

Please refer to **4.4.2 for lubrication information**.

NOTE: The carriages of sizes 15 and 20, in combination with TDC coated rails, are supplied with a low friction S0 shield as standard. Optionally, they can also be combined with an additional S7 front seal. In these cases, a slight increase in carriage length must be taken into account (↳ **page 65**).

NOTE: The availability of coated carriages in different sizes and types is shown in **table 7**.

2.1.8 Jointed rail tracks

If the requested rail length exceeds the available delivery length of LLT rails, specially paired and jointed rails can be supplied as ready-to-mount sets consisting of two or more rails (per rail track). In this case, the rails are marked in order to avoid mix-up during mounting. For specific dimensions of the joint(s), please add a drawing. The maximum length for a deliverable rail track is 50 m. Please contact Ewellix to inquire about longer individual rail tracks. If replacement is required, the complete set should be exchanged to provide full functionality.

For designation, refer to Ordering key rails (↳ **page 104**).

Parallel use of jointed rails.

When the jointed rails are use by parallely, we suggest to avoid the joint points which are between in the same position (↳ **fig. 3**).



Fig. 2

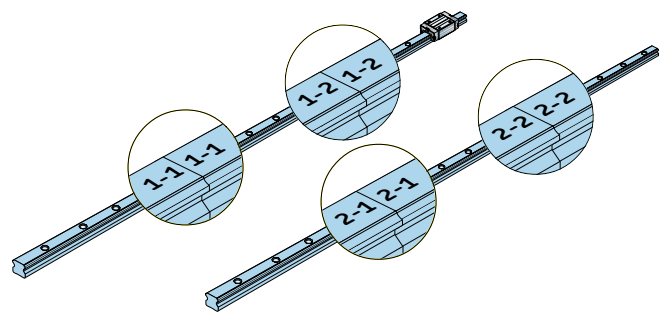
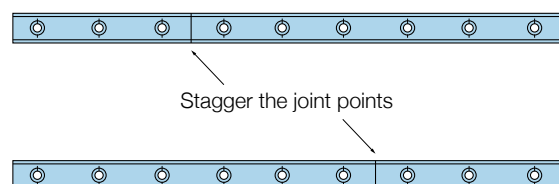

Fig. 3



2.2 Calculation of bearing loads

2.2.1 Calculation bases

The calculation methods described in this chapter must take into account all actual loads and forces acting on the individual bearings.

Static safety factor

The static safety factor is expressed as the relationship between the static load rating and the maximum static bearing load including preload (↳ page 27). The load conditions (↳ page 31) acting on the guiding system during operation must also be taken into account. The static safety factor indicates the level of safety against permanent plastic deformation of the rolling elements and raceways and is calculated according to **formula 2**.

$$(2) \quad s_0 = \frac{C_0}{P_0} = \frac{C_0}{f_d F_{res\ max}}$$

where

- C_0 = static load rating [N]
- f_d = factor for load conditions
- $F_{res\ max}$ = maximum resulting load [N]
- P_0 = maximum static load [N]
- s_0 = static safety factor

Based on practical experience, guideline values have been specified for the static safety factor, which depend on the operating mode and other external factors. (↳ table 8).

If, for example, the guiding system is exposed to vibrations from the machining process, higher safety factors should be applied. Moreover, the load transfer paths between a profile rail guide and its support structure should be taken into account. In particular, the bolted connections must be examined for sufficient safety. See also the chapter 4 **Mounting instruction and maintenance** (↳ page 74).

For overhead installations of LLT ball profile rail guides, higher safety factors should be applied. In any case, all provided attachment holes in carriage and rail are to be used in the application to make sure that loads applied on the linear guide will safely be taken and transferred.

NOTE: The maximum resulting load $F_{res\ max}$ should be calculated based on the combined static bearing load $F_{comb\ stat}$ determined according to the chapter **Combined static bearing load**, on page 27.

NOTE: The general technical rules and standards in the respective industrial sector must also be observed.

Table 8

Static safety factor depending on operating conditions	
Operating conditions	s_0
Normal conditions	min. 2
Smooth, vibration-free operation	> 2–4
Medium vibrations or impact loads	3–5
High vibrations or impact loads	> 5
Overhead installations	The general technical rules and standards in the respective industrial sector must be observed. And if the application poses a risk of serious injury, the user must take appropriate design and safety measures that will prevent the carriage from becoming detached from the rail (e.g. due to loss of rolling elements or failure of screw connections).

Basic rating life L_{10}

Under controlled laboratory conditions, seemingly identical bearings operating under identical conditions have different individual endurance lives. A clearer definition of the term “bearing life” is therefore essential to calculate bearing size.

Important: All information presented by Ewellix with regard to load ratings is based on the life that 90 % of a sufficiently large group of apparently identical bearings can be expected to attain or exceed.

Basic rating life at constant speed

If the speed is constant, the basic rating life, L_s or L_h , can be calculated using formulae 3 and 5:

$$(3) \quad L_{10s} = \left(\frac{C}{P}\right)^3 100$$

$$(4) \quad P = \frac{f_d}{f_i^3 \sqrt{f_s}} F_{res}$$

$$(5) \quad L_{10h} = \frac{5 \times 10^7}{l_s n 60} \left(\frac{C}{P}\right)^3$$

where

- C = dynamic load rating [N]
- f_d = factor for load conditions
- f_i = factor for number of carriages per rail
- F_{res} = resulting load [N]
- f_s = factor for stroke length
- L_{10h} = basic rating life [h]
- L_{10s} = basic rating life [km]
- n = stroke frequency [double strokes/min]
- P = equivalent dynamic load [N]
- l_s = single stroke length [mm]

Applying a preload

Depending on the combined bearing load and preload class, the resulting load has to be calculated according to the following methodology to get the impact on the life of LLT ball profile rail guides.

Load case 1

$$F_{comb} \leq 2,8 F_{Pr} \quad (F_{Pr} \rightarrow \text{table 9})$$

$$(6) \quad F_{res} = \left(\frac{F_{comb}}{2,8 F_{Pr}} + 1\right)^{1,5} F_{Pr}$$

Load case 2

$$F_{comb} > 2,8 F_{Pr} \quad (F_{Pr} \rightarrow \text{table 9})$$

$$(7) \quad F_{res} = F_{comb}$$

where

- F_{comb} = combined, static or dynamic bearing load [N]
- F_{Pr} = preload force [N]
- F_{res} = resulting load [N]

Table 9

Determining preload values according to preload class	
Preload class	Preload force F_{Pr}
T0	Zero to light preload For extremely smooth-running profile rail guide systems requiring low friction. This preload class is only available in P5 and P3 precision classes.
T1	$F_{Pr} = 2\%$ of C For precise profile rail guide systems with low and medium external loads and a high degree of rigidity.
T2	$F_{Pr} = 8\%$ of C For precise profile rail guide systems with high external load and high requirements for overall rigidity. Also recommended for single-rail systems. Additional common moment loads are absorbed without any significant elastic deformation.

2.2.2 Constant mean load

General calculation formulae

Equivalent dynamic mean load

The rating life calculation formulae are based on the assumption that the load and the speed are constant. In reality the external loads, positions and speeds are changing in most cases and the workflow has to be separated into load phases with constant or approximately constant conditions along their individual strokes (**diagram 3**). All single load phases are summarized to the equivalent dynamic mean load P_m depending on their individual stroke length (**formulae 8 and 9**).

$$(8) \quad P_m = \sqrt[3]{\frac{\sum_{j=1}^V |P_j|^3 s_i}{s_{tot}}}$$

$$(9) \quad s_{tot} = s_1 + s_2 + \dots + s_n$$

where

- P_m = equivalent dynamic mean load [N]
- P = equivalent dynamic load [N]
- j = counter for load phases
- V = amount of load phases
- s_i = individual stroke length [mm]
- s_{tot} = total stroke length [mm]

Maximum resulting load

The maximum value of F_{res} is required for calculating the static safety factor s . To this end, all loads must be calculated for the individual stroke lengths. With these figures, the maximum resulting load $F_{res\ max}$ can be calculated and then inserted in the equation for s_0 (**formula 2**).

$$(10) \quad F_{res\ max} = \max_{j=1}^V |F_{res,j}|$$

where

- $F_{res\ max}$ = maximum resulting load [N]
- $F_{res,j}$ = resulting load for load phase [N]
- j = counter for load phase
- V = amount of load phases

Combined bearing loads

The following chapter describes the method to calculate the combined bearing load with possible combinations of forces and moments. All load components must be constant in magnitude to enable their calculation as one load phase.

If one of the load proportions varies significantly in magnitude over the length of the stroke, a separate load phase must be calculated according to the same method.

NOTE: For the following four calculations, a load, acting on the carriage at any angle, must be broken down into the proportions F_y and F_z . These proportions are then inserted into the respective formula.

Diagram 3

Variable load acting on a carriage

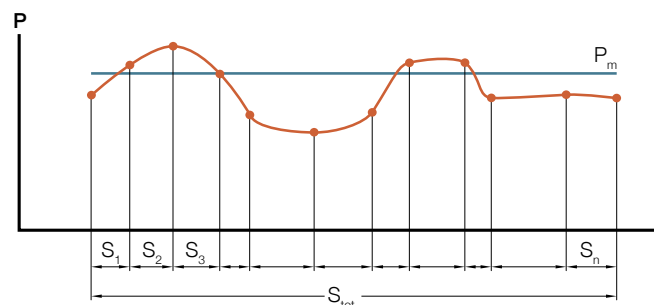

Combined static bearing load

For static vertical and horizontal loads, the combined static bearing load $F_{comb,stat}$ can be calculated using **formula 11** (↳ **fig. 4**).

Formula 11 applies to a system with two rails and four carriages (no torque loads can occur).

$$(11) \quad F_{comb,stat} = |F_y| + |F_z|$$

where

$F_{comb,stat}$ = combined static bearing load [N]

F_y, F_z = external bearing loads in y- and z-direction [N]

For combined static bearing loads – both vertical and horizontal – in combination with static moments, the combined static bearing load $F_{comb,stat}$ can be calculated using **formula 12** (↳ **fig. 5**).

$$(12) \quad F_{comb,stat} = |F_y| + |F_z| + C_0 \left(\left| \frac{M_x}{M_{xC_0}} \right| + \left| \frac{M_y}{M_{yC_0}} \right| + \left| \frac{M_z}{M_{zC_0}} \right| \right)$$

where

C_0 = static load rating [N]

$F_{comb,stat}$ = combined static bearing load [N]

F_y, F_z = external bearing loads in y- and z-direction [N]

M_x, M_y, M_z = bearing moment loads at respective coordinates [Nm]

$M_{xC_0}, M_{yC_0}, M_{zC_0}$ = permissible static moment loads [Nm]

Formula 12 can be used for the following systems:

- One rail with one carriage (all types of moment loads can occur)
- Two rails with one carriage each (M_x cannot occur)
- One rail with two carriages (M_y, M_z cannot occur)

NOTE: The maximum value of $F_{comb,stat}$ is required for calculating the static safety factor s_0 . To this end, all loads must be calculated for the individual stroke lengths. With these figures, the maximum resulting load $F_{res,max}$ can be calculated and then inserted in the equation for s_0 (**formula 2**).

Combined dynamic bearing load

For loads – both vertical and horizontal (↳ **fig. 4**) – the combined dynamic bearing load $F_{comb,dyn}$ is calculated by means of **formula 13**.

Formula 13 applies to a system with two rails and four carriages.

$$(13) \quad F_{comb,dyn} = |F_y| + |F_z|$$

where

$F_{comb,dyn}$ = combined dynamic bearing load [N]

F_y, F_z = external bearing loads in y- and z-direction [N]

NOTE: The design of the profile rail guide permits this simplified calculation. If different load stages exist for F_y and F_z , then F_y and F_z must be considered individually in **formula 8**.

When combined dynamic bearing loads and dynamic moments are present, the combined dynamic bearing load $F_{comb,dyn}$ can be calculated using **formula 14** (↳ **fig. 5**).

$$(14) \quad F_{comb,dyn} = |F_y| + |F_z| + C \left(\left| \frac{M_x}{M_{xC}} \right| + \left| \frac{M_y}{M_{yC}} \right| + \left| \frac{M_z}{M_{zC}} \right| \right)$$

where

C = dynamic load rating [N]

$F_{comb,dyn}$ = combined dynamic bearing load [N]

F_y, F_z = external bearing loads in y- and z-direction [N]

M_x, M_y, M_z = bearing moment loads at respective coordinates [Nm]

M_{xC}, M_{yC}, M_{zC} = permissible dynamic moment loads [Nm]

Formula 14 can be used for the following systems:

- One rail with one carriage (all types of moment loads can occur)
- Two rails with one carriage each (M_x cannot occur)
- One rail with two carriages (M_y, M_z cannot occur)

Fig. 4

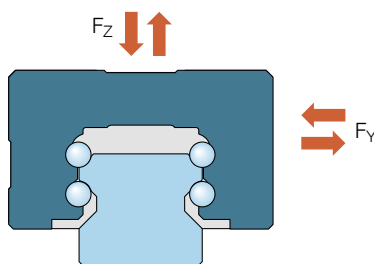
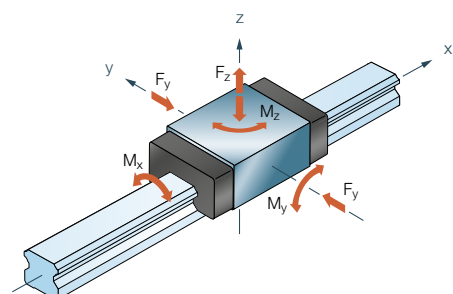

Fig. 5



Calculation examples for typical profile rail guide systems

The calculation formulas for determining the loads of carriages are shown on the following tables.

Fig.6

Loads on a system with 1 guide rail and 1 carriage

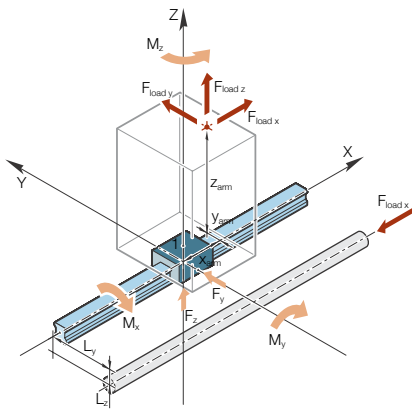

Carriage	Formula
1	Load: Force in z-direction $F_z = \sum_{j=1}^k F_{load\ z,\ j}$
1	Load: Force in y-direction $F_y = \sum_{j=1}^k F_{load\ y,\ j}$
1	Load: Moment about X-axis $M_x = \sum_{j=1}^k (F_{load\ y,\ j} \cdot z_{arm,\ j}) - \sum_{j=1}^k (F_{load\ z,\ j} \cdot y_{arm,\ j})$
1	Load: Moment about Y-axis $M_y = \sum_{j=1}^k (F_{load\ x,\ j} \cdot (z_{arm,\ j} - L_y)) - \sum_{j=1}^k (F_{load\ z,\ j} \cdot x_{arm,\ j})$
1	Load: Moment about Z-axis $M_z = -\sum_{j=1}^k (F_{load\ x,\ j} \cdot (y_{arm,\ j} - L_y)) + \sum_{j=1}^k (F_{load\ y,\ j} \cdot x_{arm,\ j})$

Fig.7

Loads on a system with 1 guide rail and 2 carriages

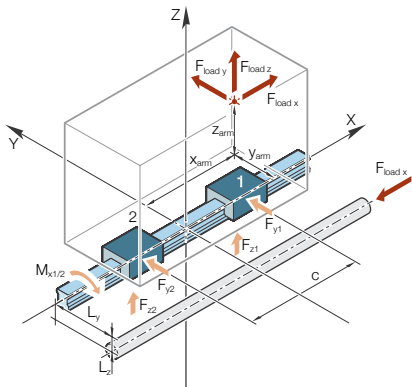

Carriage	Formula
1	Load: Force in z-direction $F_{z1} = \frac{\sum_{j=1}^k F_{load\ z,\ j}}{2} - \frac{\sum_{j=1}^k (F_{load\ x,\ j} \cdot (z_{arm,\ j} - L_y)) - \sum_{j=1}^k (F_{load\ z,\ j} \cdot x_{arm,\ j})}{c}$
2	Load: Force in z-direction $F_{z2} = \frac{\sum_{j=1}^k F_{load\ z,\ j}}{2} + \frac{\sum_{j=1}^k (F_{load\ x,\ j} \cdot (z_{arm,\ j} - L_y)) - \sum_{j=1}^k (F_{load\ z,\ j} \cdot x_{arm,\ j})}{c}$
1	Load: Force in y-direction $F_{y1} = \frac{\sum_{j=1}^k F_{load\ y,\ j}}{2} - \frac{\sum_{j=1}^k (F_{load\ x,\ j} \cdot (y_{arm,\ j} - L_y)) - \sum_{j=1}^k (F_{load\ y,\ j} \cdot x_{arm,\ j})}{c}$
2	Load: Force in y-direction $F_{y2} = \frac{\sum_{j=1}^k F_{load\ y,\ j}}{2} + \frac{\sum_{j=1}^k (F_{load\ x,\ j} \cdot (y_{arm,\ j} - L_y)) - \sum_{j=1}^k (F_{load\ y,\ j} \cdot x_{arm,\ j})}{c}$
1/2	Load: Moment about X-axis $M_{x1} = M_{x2} = \frac{\sum_{j=1}^k (F_{load\ y,\ j} \cdot z_{arm,\ j}) - \sum_{j=1}^k (F_{load\ z,\ j} \cdot y_{arm,\ j})}{2}$

Fig.6

Loads on a system with 2 guide rails and 2 carriages

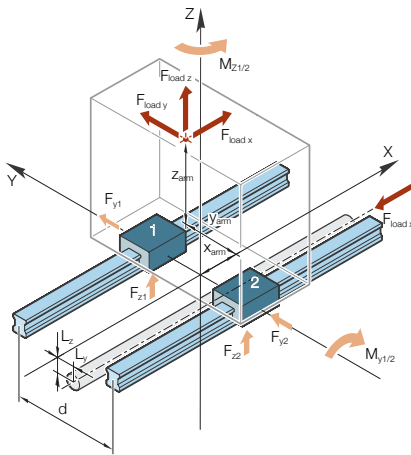

Carriage Formula

1 Load: Force in z-direction

$$F_{z1} = \frac{\sum_{j=1}^k F_{load\ z,j}}{2} - \frac{\sum_{j=1}^k (F_{load\ y,j} \cdot z_{arm,j}) - \sum_{j=1}^k (F_{load\ z,j} \cdot y_{arm,j})}{d}$$

2 Load: Force in z-direction

$$F_{z2} = \frac{\sum_{j=1}^k F_{load\ z,j}}{2} + \frac{\sum_{j=1}^k (F_{load\ y,j} \cdot z_{arm,j}) - \sum_{j=1}^k (F_{load\ z,j} \cdot y_{arm,j})}{d}$$

1/2 Load: Force in y-direction

$$F_{y1} = F_{y2} = \frac{\sum_{j=1}^k F_{load\ y,j}}{2}$$

1/2 Load: Moment about Y-axis

$$M_{y1} = M_{y2} = \frac{\sum_{j=1}^k (F_{load\ x,j} \cdot (z_{arm,j} - L_2)) - \sum_{j=1}^k (F_{load\ z,j} \cdot x_{arm,j})}{2}$$

1/2 Load: Moment about Z-axis

$$M_{z1} = M_{z2} = \frac{-\sum_{j=1}^k (F_{load\ x,j} \cdot (y_{arm,j} - L_1)) + \sum_{j=1}^k (F_{load\ y,j} \cdot y_{arm,j})}{2}$$

Fig.7

Loads on a system with 2 guide rails and 4 carriages

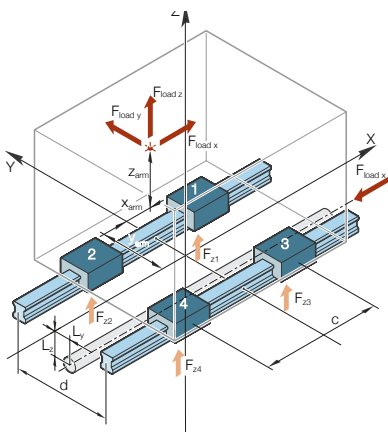

Carriage Formula

1 Load: Force in z-direction

$$F_{z1} = \frac{\sum_{j=1}^k F_{load\ z,j}}{4} + \frac{\sum_{j=1}^k (F_{load\ x,j} \cdot y_{arm,j}) - \sum_{j=1}^k (F_{load\ y,j} \cdot z_{arm,j})}{2 \cdot d} + \frac{\sum_{j=1}^k (F_{load\ z,j} \cdot x_{arm,j}) - \sum_{j=1}^k (F_{load\ x,j} \cdot (z_{arm,j} - L_2))}{2 \cdot c}$$

2 Load: Force in z-direction

$$F_{z2} = \frac{\sum_{j=1}^k F_{load\ z,j}}{4} + \frac{\sum_{j=1}^k (F_{load\ z,j} \cdot y_{arm,j}) - \sum_{j=1}^k (F_{load\ y,j} \cdot z_{arm,j})}{2 \cdot d} + \frac{\sum_{j=1}^k (F_{load\ x,j} \cdot (z_{arm,j} - L_2)) - \sum_{j=1}^k (F_{load\ z,j} \cdot x_{arm,j})}{2 \cdot c}$$

3 Load: Force in z-direction

$$F_{z3} = \frac{\sum_{j=1}^k F_{load\ z,j}}{4} + \frac{\sum_{j=1}^k (F_{load\ y,j} \cdot z_{arm,j}) - \sum_{j=1}^k (F_{load\ z,j} \cdot y_{arm,j})}{2 \cdot d} + \frac{\sum_{j=1}^k (F_{load\ z,j} \cdot x_{arm,j}) - \sum_{j=1}^k (F_{load\ x,j} \cdot (z_{arm,j} - L_2))}{2 \cdot c}$$

4 Load: Force in z-direction

$$F_{z4} = \frac{\sum_{j=1}^k F_{load\ z,j}}{4} + \frac{\sum_{j=1}^k (F_{load\ y,j} \cdot z_{arm,j}) - \sum_{j=1}^k (F_{load\ z,j} \cdot y_{arm,j})}{2 \cdot d} + \frac{\sum_{j=1}^k (F_{load\ x,j} \cdot (z_{arm,j} - L_2)) - \sum_{j=1}^k (F_{load\ z,j} \cdot x_{arm,j})}{2 \cdot c}$$



2.2.3 Factors of influence

Requisite reliability

Factor c_1 is used for lifetime calculations where a reliability higher than 90 % is needed. The corresponding values can be found in (↳ **table 10**).

Operating conditions

The lubrication effectiveness is strongly dependent on the degree of separation between the rolling elements and race-way surfaces in the contact zones. A specific minimum viscosity is required for the formation of an effectively separating lubricating film at operating temperature, taking into account the kinematic conditions. Assuming a normal level of cleanliness of the profile rail guide as well as effective sealing, factor c_2 depends on the viscosity ratio κ exclusively. κ designates the ratio between the actual kinematic viscosity and the requisite minimum viscosity (↳ **formula 15**).

$$(15) \quad \kappa = \frac{v}{v_1}$$

where

κ = viscosity ratio

v = actual kinematic viscosity [mm²/s]

v_1 = requisite minimum viscosity [mm²/s]

The requisite minimum viscosity v_1 for LLT guides depends on the mean speed (↳ **diagram 3**).

The value for v_1 can be related to the actual viscosity v according to formula 15 in order to obtain κ . Now c_2 can be taken from (↳ **diagram 4**). If the viscosity ratio κ is less than 1, a lubricant with EP additives is recommended. If lubricant with EP additives are used, the higher value for c_2 can be used for calculation.

Table 10

Factor c_1 for reliability		
Reliability %	L_{ns}	c_1
90	L_{10s}	1
95	L_{5s}	0,62
96	L_{4s}	0,53
97	L_{3s}	0,44
98	L_{2s}	0,33
99	L_{1s}	0,21

Diagram 3

Determining the requisite minimum viscosity v_1

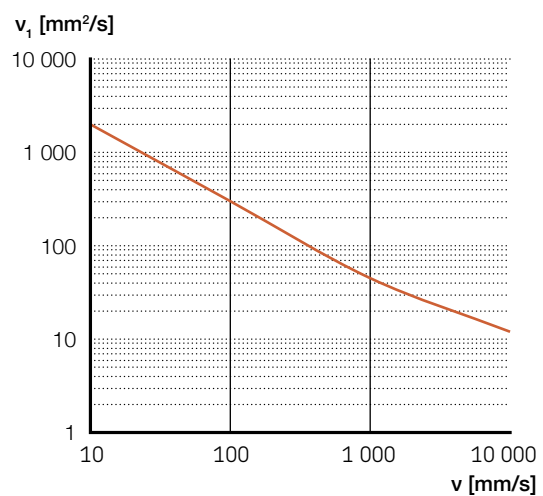
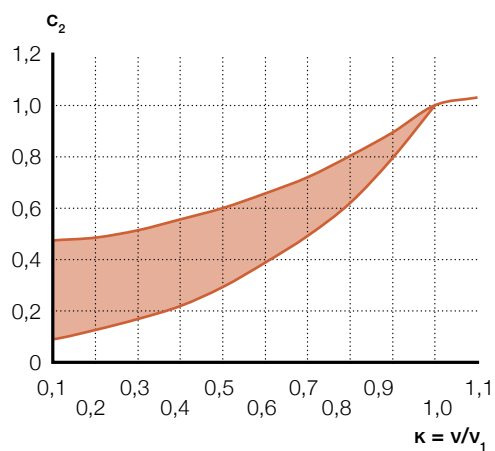

Diagram 4

Determining factor c_2 for operating conditions



2.2.4 Load conditions

The load acting on an LLT ball profile rail guide is resulting from acceleration, impact loads and vibration. It is extremely difficult to quantify these additional dynamic forces. To approximate the impact these indeterminate loads will have on the life of the system, the load must be multiplied by factor f_d . Depending on the mean speed and strength of the impact load, values listed in **table 11** can be selected for f_d .

Number of carriages per rail

Most profile rail guide configurations feature two or more carriages mounted on one rail. The load distribution on these various carriages is strongly influenced by the mounting precision, the manufacturing quality of the adjacent components, and particularly, the distance between the carriages. Factor f_i takes these influences on carriage loading into account based on the number of carriages per rail and their distance relative to each other (↳ **table 12** and **fig. 10**).

Impact of stroke length

Strokes that are shorter than the metal body of the carriage (dimension L_2) have a negative influence on the achievable life of a guiding system. If the stroke is longer than the carriage metal body length, the factor is $f_s = 1$. Sequenced load phases with identical moving direction deliver a sub stroke length (S_s) according to **formula 16** to determine f_s . Based on the ratio of the sub stroke lengths (S_s) to the metal body of the carriage L_2 , the factor f_s is determined according to **table 13**.

$$(16) \quad S_s = \sum_{j=A}^B S_j$$

where

- S_s = sub stroke length [mm]
- S_j = individual stroke length [mm]
- j = counter for load phases
- A = starting point of movement in one direction
- B = next reversal point

Table 11

Factor f_d for load conditions		
Load conditions	f_d from	up to
Smooth operation, no or light impact loads Speed ≤ 2 m/s	1,0	1,5
High impact loads Speed > 2 m/s	1,5	3,0

Table 12

Factor f_i for number of carriages per rail		
Number of carriages	If $c \geq 1,5 \cdot L_2$ f_i	If $c < 1,5 \cdot L_2$ f_i
1	1	1
2	1	0,81
3	1	0,72

Table 13

Factor f_s depending on the ratio S_s/L_2	
S_s/L_2	f_s
1,0	1,0
0,9	0,91
0,8	0,82
0,7	0,73
0,6	0,63
0,5	0,54
0,4	0,44
0,3	0,34
0,2	0,23

Fig. 10

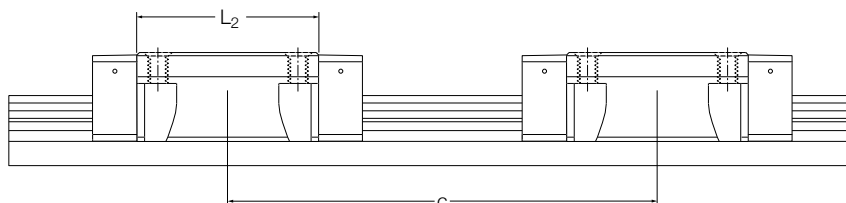

2.2.5 Modified basic rating life

If the load situation is known and the factors have been determined, then the modified basic rating life can be calculated with **formula 17**

$$(17) \quad L_{ns} = 100 c_1 c_2 f_s \left(\frac{f_i C}{f_d F_{res}} \right)^3$$

In the presence of varying forces as described in the section **2.2.1 Calculation bases** (↳ **page 24**), **formula 17** is extended to account for the impacts of operating conditions and loads per phase. This is described in **formula 18**:

$$(18) \quad L_{ns} = 100 c_1 c_2 \frac{(f_i C)^3 s_{tot}}{\sum_{j=1}^V \left(\left| \frac{f_{d,j} F_{res,j}}{\sqrt[3]{f_{s,j}}} \right|^3 s_j \right)}$$

where

- C = dynamic load rating [N]
- c_1 = factor for reliability
- c_2 = factor for operating conditions
- f_d = factor for load conditions
- $f_{d,j}$ = factor for load conditions for load phase j
- f_i = factor for number of carriages per rail
- F_{res} = resulting load [N]
- $F_{res,j}$ = resulting load for load phase j [N]
- f_s = factor for stroke length
- $f_{s,j}$ = factor for stroke length for load phase j
- j = counter for load phases
- L_{ns} = modified basic rating life [km]
- s_i = individual stroke length [mm]
- s_{tot} = total stroke length [mm]
- V = amount of load phases

2.2.6 Linear guide calculation tools

Ewellix calculation program

Details pertaining to all the relevant load situations and the specification of the general design conditions are crucial for precisely calculating the life expectancy and static load safety of an LLT profile rail guide system in a specific application. Ultimately, this information determines the size and carriage type of the LLT profile rail guide. This design process can be quite extensive for complex applications.

Therefore, Ewellix offers the “Linear guide select” calculation program which is available at www.ewellix.com. This calculation program supports the user and is extremely effective in the design of LLT profile rail guide systems.

The following information must be available prior to starting a calculation:

- number of load cases
- moved masses as well as operating loads including coordinates
- travel proportions of operating loads
- reaction forces accommodated by the drive system (in the direction of travel)
- selection of preload applied to the guide
- layout (number of rails and carriages)
- geometry of linear axis (distance between rails relative to each other and carriages relative to each other)

NOTE: If the user is free to select the application coordinate system, Ewellix recommends using the coordinate system in the program. This facilitates the analysis of all operating loads and the resulting reaction forces in the carriages and prevents transformation errors.

Representation of results

When the calculation routine is complete, the user will receive the following data in a clearly structured form:

- all input data
- load values per carriage in the y- and z-direction and external loads for all conceivable load cases
- calculation of equivalent dynamic load per carriage
- basic rating life of carriages
- static load safety of carriages

Depending on the expected life or static load safety, various carriage sizes can be selected for printout.

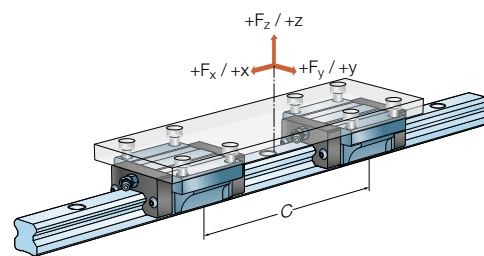
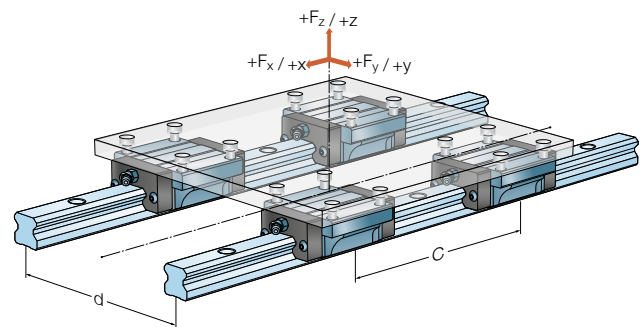

2.2.7 Legend

Legend	
C	dynamic load capacity; also dynamic load rating [N]
C_0	static load capacity; also static load rating [N]
c_1	factor for reliability
c_2	factor for operating conditions
f	factor for load conditions
$f_{d1}, f_{d2} \dots f_{dn}$	factor for load conditions during stroke length $s_1, s_2 \dots s_n$
f_i	factor for number of carriages per rail
f_s	factor for stroke length
F	external bearing load [N]
F_y, F_z	external bearing loads in y- and z-direction [N]
F_{Pr}	preload force [N]
F_{res}	resulting load [N]
$F_{res 1}, F_{res 2} \dots F_{res n}$	resulting load during stroke length s_1, s_2, \dots, s_n [N]
$F_{res max}$	maximum resulting load [N]
F_m	constant mean load [N]
K	viscosity ratio
L_{10h}	basic rating life [h]
L_{10s}	basic rating life [km]
L_{ns}	modified basic rating life [km]
M_x, M_y, M_z	moment loads at respective coordinates [Nm]
M_{xC}, M_{yC}, M_{zC}	permissible dynamic moment loads [Nm]
$M_{xC_0}, M_{yC_0}, M_{zC_0}$	permissible static moment loads [Nm]
n	stroke frequency [double strokes/min]
n	actual kinematic viscosity [mm ² /s]
n_1	requisite minimum viscosity [mm ² /s]
P	equivalent dynamic load [N]
P_0	maximum static load [N]
l_s	single stroke length [mm]
s_0	static safety factor
s_j	individual stroke length per phase [mm]
S_s	sub stroke length [mm]
s_{tot}	total stroke length [mm]
$t_1, t_2 \dots t_n$	time proportions for $v_1, v_2 \dots v_n$ [%]
$v_1, v_2 \dots v_n$	speed [m/min]
v_m	mean speed [m/min]
V	amount of load phases
c	center distance of carriages [mm]
d	center distance between the rails [mm]

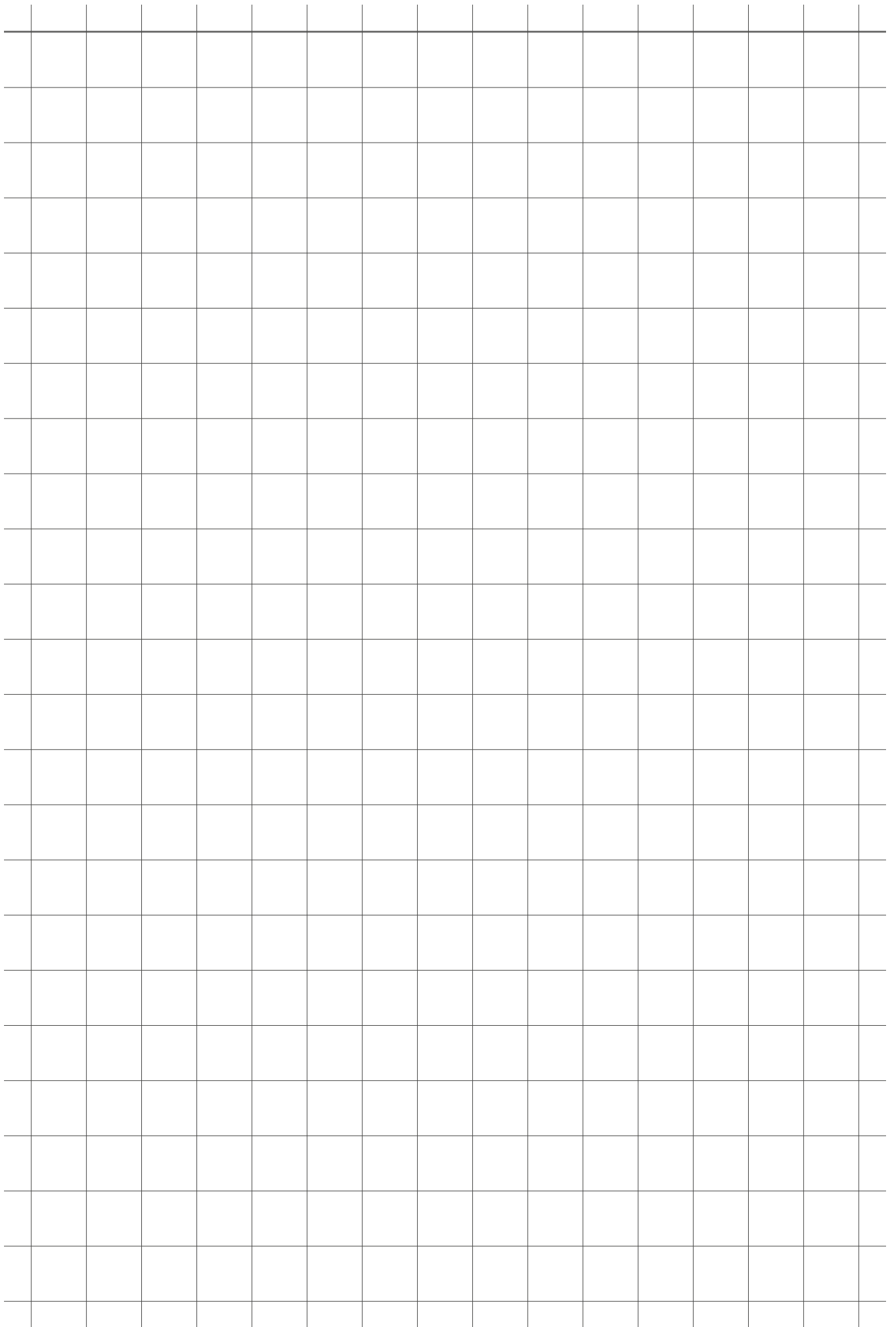

3

Product range



3.1 Carriage data

LLTHC ... SA
Flanged carriage, short length, standard height

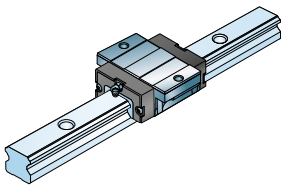

Size ¹⁾	Load ratings	
	C	C ₀
-	N	
15	5 800	9 000
20	9 240	14 400
25	13 500	19 600
30	19 200	26 600
35	25 500	34 800
45	-	-

LLTHC ... A
Flanged carriage, standard length, standard height

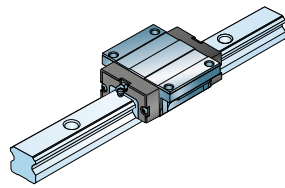

Size ¹⁾	Load ratings	
	C	C ₀
-	N	
15	8 400	15 400
20	12 400	24 550
25	18 800	30 700
30	26 100	41 900
35	34 700	54 650
45	59 200	91 100

LLTHC ... LA
Flanged carriage, extended length, standard height

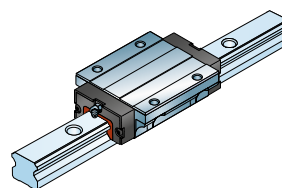

Size ¹⁾	Load ratings	
	C	C ₀
-	N	
15	-	-
20	15 200	32 700
25	24 400	44 600
30	33 900	60 800
35	45 000	79 400
45	72 400	121 400

LLTHC ... SU
Slim-line carriage, short length, standard height

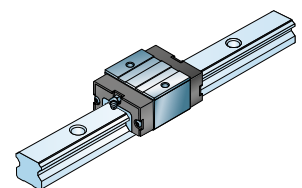

Size ¹⁾	Load ratings	
	C	C ₀
-	N	
15	5 800	9 000
20	9 240	14 400
25	13 500	19 600
30	19 200	26 600
35	25 500	34 800
45	-	-

LLTHC ... U
Slim-line carriage, standard length, standard height

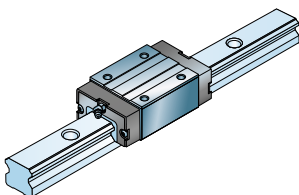

Size ¹⁾	Load ratings	
	C	C ₀
-	N	
15	8 400	15 400
20	12 400	24 550
25	18 800	30 700
30	26 100	41 900
35	34 700	54 650
45	59 200	91 100

LLTHC ... LU
Slim-line carriage, extended length, standard height

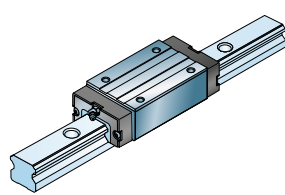

Size ¹⁾	Load ratings	
	C	C ₀
-	N	
15	-	-
20 ²⁾	15 200	32 700
25	24 000	44 600
30	33 900	60 800
35	45 000	79 400
45	72 400	121 400

LLTHC ... R
Slim-line carriage, standard length, extended height

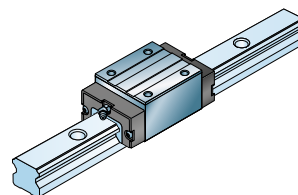

Size ¹⁾	Load ratings	
	C	C ₀
-	N	
15	8 400	15 400
20	-	-
25	18 800	30 700
30	26 100	41 900
35	34 700	54 650
45	59 200	91 100

LLTHC ... LR
Slim-line carriage, extended length, extended height

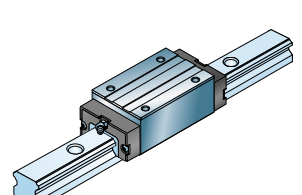

Size ¹⁾	Load ratings	
	C	C ₀
-	N	
15	-	-
20 ²⁾	15 200	32 700
25	24 400	44 600
30	33 900	60 800
35	45 000	79 400
45	72 400	121 400

¹⁾ Front seal appearance can slightly deviate by size.

²⁾ LLLTHC 20 LU and LLTHC 20 LR is the same product



3.1.1 Carriage LLTHC ... SA

Flanged carriage, short length, standard height.

Carriages from size 15 to 30 are also available with low friction S0 shield. Dimensions are the same as standard version. For designation, refer to **Ordering key carriages** (↳ page 103).

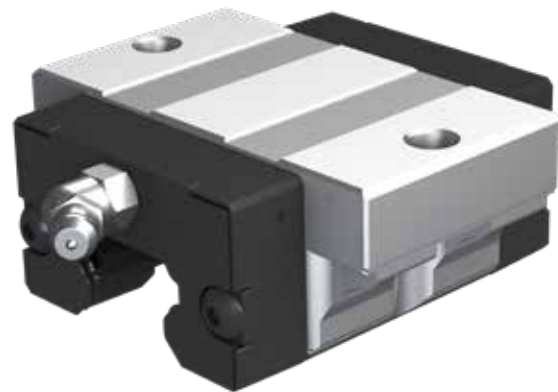

Technical data

Size	Precision class	Designation ¹⁾ Preload class T0	T1
-	-	-	-
15	P5	LLTHC 15 SA T0 P5	LLTHC 15 SA T1 P5
	P3	LLTHC 15 SA T0 P3	LLTHC 15 SA T1 P3
	P1		LLTHC 15 SA T1 P1
20	P5	LLTHC 20 SA T0 P5	LLTHC 20 SA T1 P5
	P3	LLTHC 20 SA T0 P3	LLTHC 20 SA T1 P3
	P1		LLTHC 20 SA T1 P1
25	P5	LLTHC 25 SA T0 P5	LLTHC 25 SA T1 P5
	P3	LLTHC 25 SA T0 P3	LLTHC 25 SA T1 P3
	P1		LLTHC 25 SA T1 P1
30	P5	LLTHC 30 SA T0 P5	LLTHC 30 SA T1 P5
	P3	LLTHC 30 SA T0 P3	LLTHC 30 SA T1 P3
	P1		LLTHC 30 SA T1 P1
35	P5	LLTHC 35 SA T0 P5	LLTHC 35 SA T1 P5
	P3	LLTHC 35 SA T0 P3	LLTHC 35 SA T1 P3
	P1		LLTHC 35 SA T1 P1

¹⁾ • Preferred range.

- Only available as system.

For designation, please refer to designation system.

Dimensional drawing

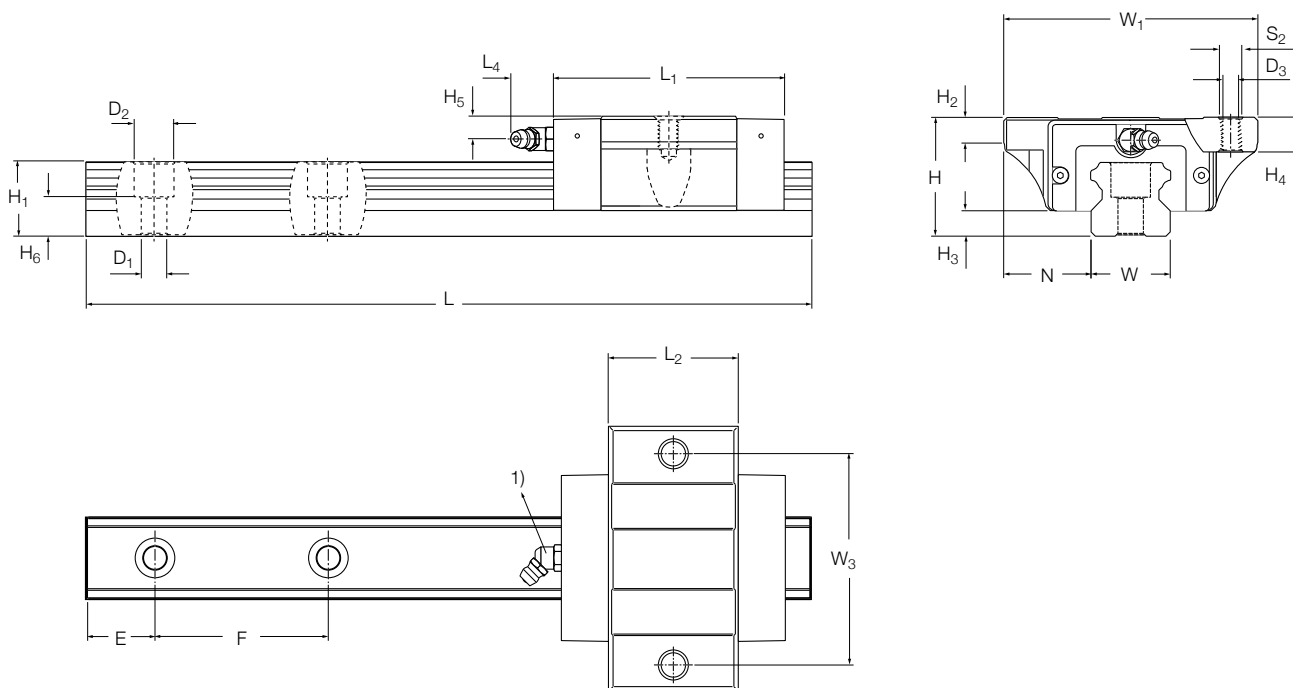

Size	Assembly dimensions					Carriage dimensions							
	W ₁ mm	N	H	H ₂	H ₃	L ₁	L ₂	L ₄	W ₃	H ₄	H ₅	D ₃	S ₂
15	47	16	24	5,7	4,6	48,9	25,6	4,3	38	8	4,3	4,3	M5×0,8
20	63	21,5	30	6,7	5	55,4	32,1	15	53	9	5,7	5,2	M6×1,0
25	70	23,5	36	10,8	7	66,2	38,8	16,6	57	12	6,5	6,7	M8×1,25
30	90	31	42	8,8	9	78	45	14,6	72	11,5	8	8,5	M10×1,5
35	100	33	48	12,1	9,5	88,8	51,4	14,6	82	13	8	8,5	M10×1,5

Size	Rail dimensions									Weight carriage rail kg	kg/m	Load ratings ²⁾		Moments ²⁾			
	W	H ₁	H ₆	F	D ₁	D ₂	E _{min} ±0,75	E _{max} ±0,75	L _{max} ±1,5			dynamic C	static C ₀	dynamic M _{xc} Nm	static M _{xc0} Nm	dynamic M _{yc} =M _{zc} Nm	static M _{yc0} =M _{zc0} Nm
15	15	14	8,5	60	4,5	7,5	10	50	3 920	0,12	1,4	5 800	9 000	39	60	21	32
20	20	18	9,3	60	6	9,5	10	50	3 920	0,25	2,3	9 240	14 400	83	130	41	64
25	23	22	12,3	60	7	11	10	50	3 920	0,38	3,3	13 500	19 600	139	202	73	106
30	28	26	13,8	80	9	14	12	70	3 944	0,56	4,8	19 200	26 600	242	335	120	166
35	34	29	17	80	9	14	12	70	3 944	0,83	6,6	25 500	34 800	393	536	182	248

¹⁾ For detailed information on grease nipples, please refer to **page 70**.

²⁾ Dynamic load capacities and moments are based on a travel life of 100 km. Please refer to **page 15** for further details.

3.1.2 Carriage LLTHC ... A

Flanged carriage, short length, standard height.

Carriages from size 15 to 30 are also available with low friction S0 shield. Dimensions are the same as standard version. For designation, refer to **Ordering key carriages** (→ page 103).



Technical data

Size	Precision class	Designation ¹⁾ Preload class T0	T1	T2
–		–		
15	P5	LLTHC 15 A T0 P5	LLTHC 15 A T1 P5	LLTHC 15 A T2 P5
	P3	LLTHC 15 A T0 P3	LLTHC 15 A T1 P3	LLTHC 15 A T2 P3
	P1	LLTHC 15 A T0 P1	LLTHC 15 A T1 P1	LLTHC 15 A T2 P1
20	P5	LLTHC 20 A T0 P5	LLTHC 20 A T1 P5	LLTHC 20 A T2 P5
	P3	LLTHC 20 A T0 P3	LLTHC 20 A T1 P3	LLTHC 20 A T2 P3
	P1	LLTHC 20 A T0 P1	LLTHC 20 A T1 P1	LLTHC 20 A T2 P1
25	P5	LLTHC 25 A T0 P5	LLTHC 25 A T1 P5	LLTHC 25 A T2 P5
	P3	LLTHC 25 A T0 P3	LLTHC 25 A T1 P3	LLTHC 25 A T2 P3
	P1	LLTHC 25 A T0 P1	LLTHC 25 A T1 P1	LLTHC 25 A T2 P1
30	P5	LLTHC 30 A T0 P5	LLTHC 30 A T1 P5	LLTHC 30 A T2 P5
	P3	LLTHC 30 A T0 P3	LLTHC 30 A T1 P3	LLTHC 30 A T2 P3
	P1	LLTHC 30 A T0 P1	LLTHC 30 A T1 P1	LLTHC 30 A T2 P1
35	P5	LLTHC 35 A T0 P5	LLTHC 35 A T1 P5	LLTHC 35 A T2 P5
	P3	LLTHC 35 A T0 P3	LLTHC 35 A T1 P3	LLTHC 35 A T2 P3
	P1	LLTHC 35 A T0 P1	LLTHC 35 A T1 P1	LLTHC 35 A T2 P1
45	P5	LLTHC 45 A T0 P5	LLTHC 45 A T1 P5	LLTHC 45 A T2 P5
	P3	LLTHC 45 A T0 P3	LLTHC 45 A T1 P3	LLTHC 45 A T2 P3
	P1	LLTHC 45 A T0 P1	LLTHC 45 A T1 P1	LLTHC 45 A T2 P1

¹⁾ • Preferred range.

• Only available as system.

For designation, please refer to designation system.

Dimensional drawing

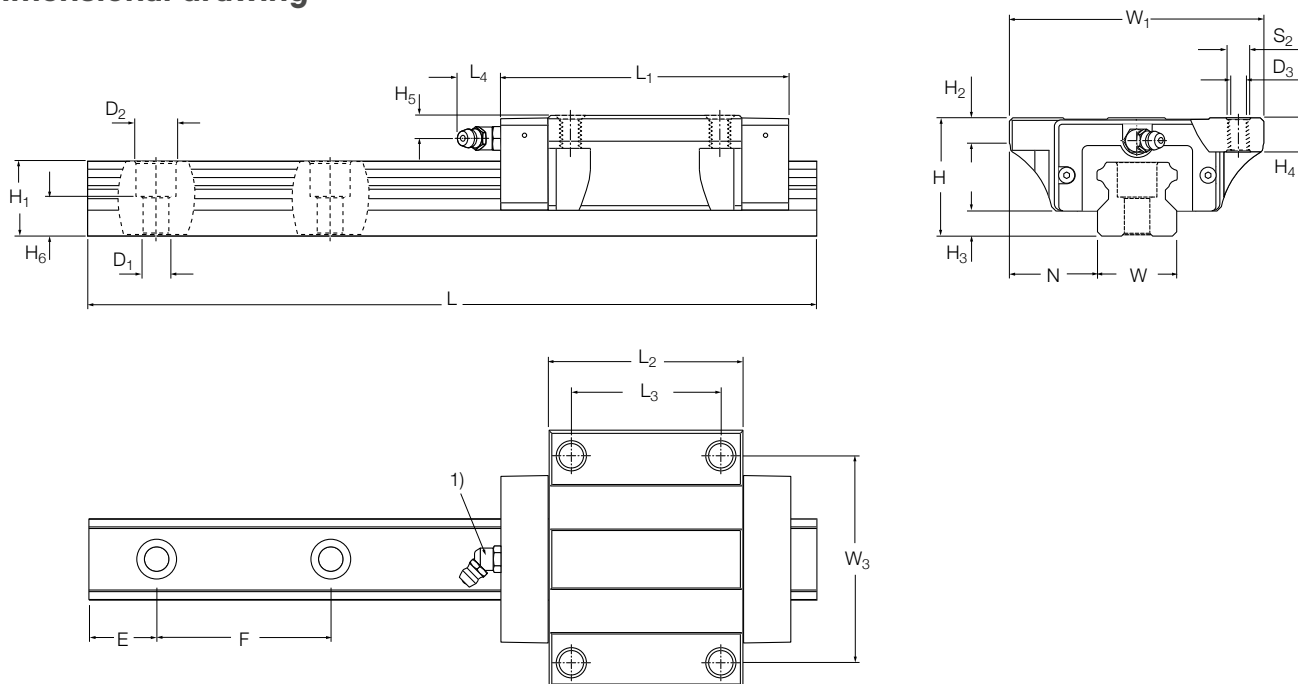

Size	Assembly dimensions					Carriage dimensions									
	W ₁ mm	N	H	H ₂	H ₃	L ₁	L ₂	L ₃	L ₄	W ₃	H ₄	H ₅	D ₃	S ₂	
15	47	16	24	5,7	4,6	63,3	40	30	4,3	38	8	4,3	4,3	M5×0,8	
20	63	21,5	30	6,7	5	73,3	50	40	15	53	9	5,7	5,2	M6×1,0	
25	70	23,5	36	10,8	7	84,4	57	45	16,6	57	12	6,5	6,7	M8×1,25	
30	90	31	42	8,8	9	100,4	67,4	52	14,6	72	11,5	8	8,5	M10×1,5	
35	100	33	48	12,1	9,5	114,4	77	62	14,6	82	13	8	8,5	M10×1,5	
45	120	37,5	60	12,1	14	136,5	96	80	14,6	100	15	8,5	10,4	M12×1,75	

Size	Rail dimensions									Weight		Load ratings ²⁾		Moments ²⁾			
	W	H ₁	H ₆	F	D ₁	D ₂	E _{min} ±0,75	E _{max} ±0,75	L _{max} ±1,5	carriage	kg	kg/m	dynamic C	static C ₀	dynamic M _{xC}	static M _{xC₀}	dynamic M _{yC} =M _{zC}
-	mm									kg	kg/m	N	Nm				
15	15	14	8,5	60	4,5	7,5	10	50	3 920	0,21	1,4	8 400	15 400	56	103	49	90
20	20	18	9,3	60	6	9,5	10	50	3 920	0,4	2,3	12 400	24 550	112	221	90	179
25	23	22	12,3	60	7	11	10	50	3 920	0,57	3,3	18 800	30 700	194	316	155	254
30	28	26	13,8	80	9	14	12	70	3 944	1,1	4,8	26 100	41 900	329	528	256	410
35	34	29	17	80	9	14	12	70	3 944	1,6	6,6	34 700	54 650	535	842	388	611
45	45	38	20,8	105	14	20	16	90	3 917	2,7	11,3	59 200	91 100	1215	1869	825	1 270

¹⁾ For detailed information on grease nipples, please refer to page 70.

²⁾ Dynamic load capacities and moments are based on a travel life of 100 km. Please refer to page 15 for further details.

3.1.3 Carriage LLTHC ... LA

Flanged carriage, extended length, standard height.

Carriages from size 20 to 30 are also available with low friction S0 shield. Dimensions are the same as standard version. For designation, refer to **Ordering key carriages** (↳ page 103).



Technical data

Size	Precision class	Designation ¹⁾ Preload class T0	T1	T2
–		–		
20	P5	LLTHC 20 LA T0 P5	LLTHC 20 LA T1 P5	LLTHC 20 LA T2 P5
	P3	LLTHC 20 LA T0 P3	LLTHC 20 LA T1 P3	LLTHC 20 LA T2 P3
	P1	LLTHC 20 LA T0 P1	LLTHC 20 LA T1 P1	LLTHC 20 LA T2 P1
25	P5	LLTHC 25 LA T0 P5	LLTHC 25 LA T1 P5	LLTHC 25 LA T2 P5
	P3	LLTHC 25 LA T0 P3	LLTHC 25 LA T1 P3	LLTHC 25 LA T2 P3
	P1	LLTHC 25 LA T0 P1	LLTHC 25 LA T1 P1	LLTHC 25 LA T2 P1
30	P5	LLTHC 30 LA T0 P5	LLTHC 30 LA T1 P5	LLTHC 30 LA T2 P5
	P3	LLTHC 30 LA T0 P3	LLTHC 30 LA T1 P3	LLTHC 30 LA T2 P3
	P1	LLTHC 30 LA T0 P1	LLTHC 30 LA T1 P1	LLTHC 30 LA T2 P1
35	P5	LLTHC 35 LA T0 P5	LLTHC 35 LA T1 P5	LLTHC 35 LA T2 P5
	P3	LLTHC 35 LA T0 P3	LLTHC 35 LA T1 P3	LLTHC 35 LA T2 P3
	P1	LLTHC 35 LA T0 P1	LLTHC 35 LA T1 P1	LLTHC 35 LA T2 P1
45	P5	LLTHC 45 LA T0 P5	LLTHC 45 LA T1 P5	LLTHC 45 LA T2 P5
	P3	LLTHC 45 LA T0 P3	LLTHC 45 LA T1 P3	LLTHC 45 LA T2 P3
	P1	LLTHC 45 LA T0 P1	LLTHC 45 LA T1 P1	LLTHC 45 LA T2 P1

¹⁾ • Preferred range.

• Only available as system.

For designation, please refer to designation system.

Dimensional drawing

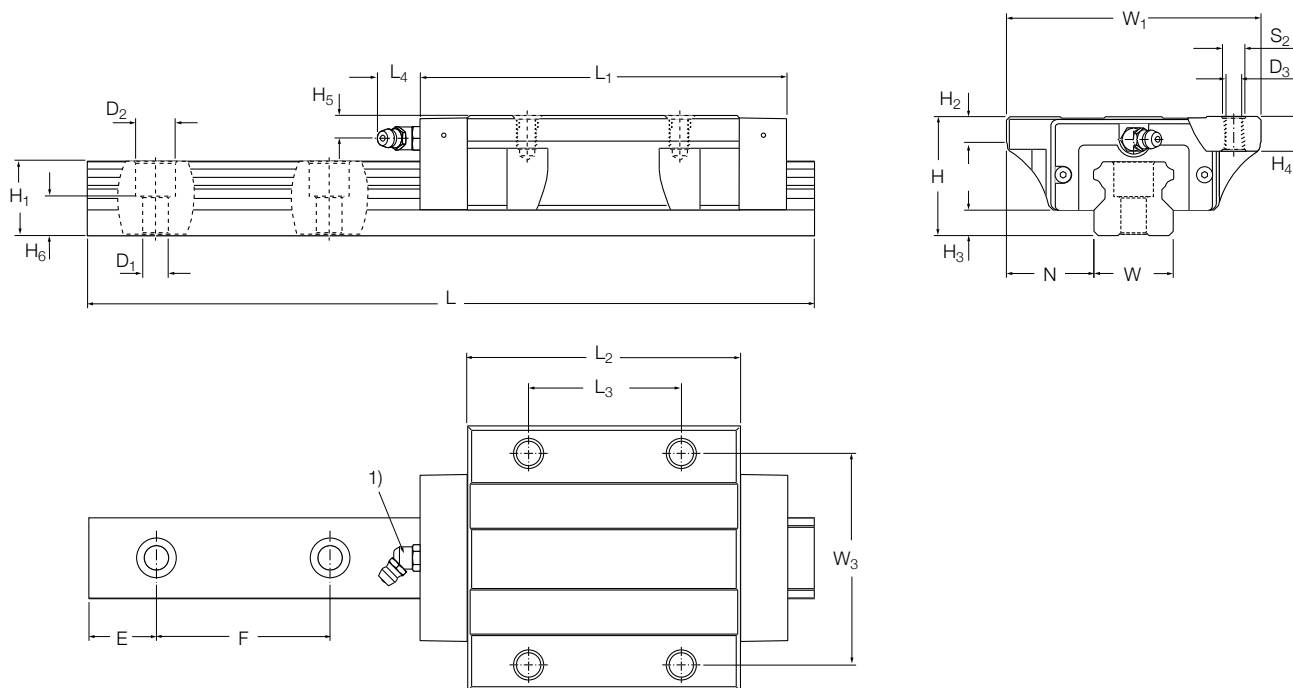

Size	Assembly dimensions					Carriage dimensions								
	W ₁ mm	N	H	H ₂	H ₃	L ₁	L ₂	L ₃	L ₄	W ₃	H ₄	H ₅	D ₃	S ₂
20	63	21,5	30	6,7	5	89,5	66,2	40	15	53	9	5,7	5,2	M6×1,0
25	70	23,5	36	10,8	7	106,5	79,1	45	16,6	57	12	6,5	6,7	M8×1,25
30	90	31	42	8,8	9	125,4	92,4	52	14,6	72	11,5	8	8,5	M10×1,5
35	100	33	48	12,1	9,5	142,9	105,5	62	14,6	82	13	8	8,5	M10×1,5
45	120	37,5	60	12,1	14	168,5	128	80	14,6	100	15	8,5	10,4	M12×1,75

Size	Rail dimensions					Weight		Load ratings 2)		Moments 2)							
	W	H ₁	H ₆	F	D ₁	D ₂	E _{min} ±0,75	E _{max} ±0,75	L _{max} ±1,5	carriage	rail	dynamic C	static C ₀	dynamic M _{xc}	static M _{xc0}	dynamic M _{yc} =M _{zc}	static M _{yc0} =M _{zc0}
–	mm					kg	kg/m	N		Nm							
20	20	18	9,3	60	6	9,5	10	50	3 920	0,52	2,3	15 200	32 700	137	295	150	322
25	23	22	12,3	60	7	11	10	50	3 920	0,72	3,3	24 400	44 600	252	460	287	525
30	28	26	13,8	80	9	14	12	70	3 944	1,4	4,8	33 900	60 800	428	767	466	836
35	34	29	17	80	9	14	12	70	3 944	2	6,6	45 000	79 400	694	1 224	706	1 246
45	45	38	20,8	105	14	20	16	90	3 917	3,6	11,3	72 400	121 400	1 485	2 491	1 376	2 308

¹⁾ For detailed information on grease nipples, please refer to **page 70**.

²⁾ Dynamic load capacities and moments are based on a travel life of 100 km. Please refer to **page 15** for further details.

3.1.4 Carriage LLTHC ... SU

Slim-line carriage, short length, standard height.

Carriages from size 15 to 30 are also available with low friction S0 shield. Dimensions are the same as standard version. For designation, refer to **Ordering key carriages** (↳ page 103).



Technical data

Size	Precision class	Designation ¹⁾ Preload class T0	T1
-		-	
15	P5	LLTHC 15 SU T0 P5	LLTHC 15 SU T1 P5
	P3	LLTHC 15 SU T0 P3	LLTHC 15 SU T1 P3
	P1		LLTHC 15 SU T1 P1
20	P5	LLTHC 20 SU T0 P5	LLTHC 20 SU T1 P5
	P3	LLTHC 20 SU T0 P3	LLTHC 20 SU T1 P3
	P1		LLTHC 20 SU T1 P1
25	P5	LLTHC 25 SU T0 P5	LLTHC 25 SU T1 P5
	P3	LLTHC 25 SU T0 P3	LLTHC 25 SU T1 P3
	P1		LLTHC 25 SU T1 P1
30	P5	LLTHC 30 SU T0 P5	LLTHC 30 SU T1 P5
	P3	LLTHC 30 SU T0 P3	LLTHC 30 SU T1 P3
	P1		LLTHC 30 SU T1 P1
35	P5	LLTHC 35 SU T0 P5	LLTHC 35 SU T1 P5
	P3	LLTHC 35 SU T0 P3	LLTHC 35 SU T1 P3
	P1		LLTHC 35 SU T1 P1

¹⁾ • Preferred range.

• Only available as system.

For designation, please refer to designation system.

Dimensional drawing

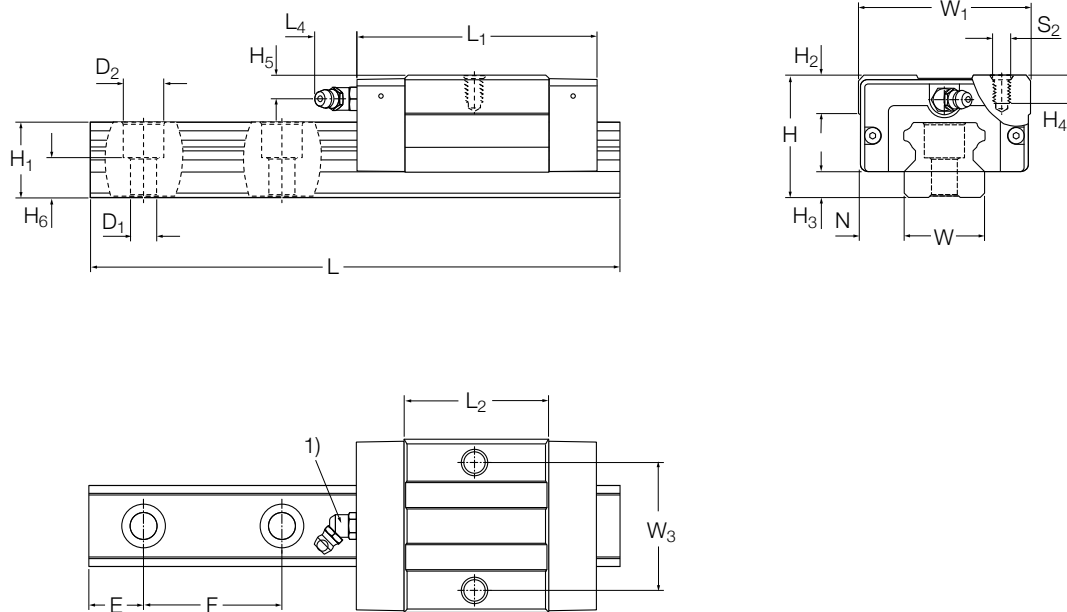

Size	Assembly dimensions				Carriage dimensions							
	W ₁ mm	N	H	H ₂	H ₃	L ₁	L ₂	L ₄	W ₃	H ₄	H ₅	S ₂
15	34	9,5	24	4,8	4,6	48,9	25,6	4,3	26	4	4,3	M4x0,7
20	44	12	30	9,3	5	55,4	32,1	15	32	6,5	5,7	M5x0,8
25	48	12,5	36	9,6	7	66,2	38,8	16,6	35	6,5	6,5	M6x1,0
30	60	16	42	12,6	9	78	45	14,6	40	8,5	8	M8x1,25
35	70	18	48	12,3	9,5	88,8	51,4	14,6	50	10	8	M8x1,25

Size	Rail dimensions										Weight carriage rail	Load ratings ²⁾		Moments ²⁾			
	W	H ₁	H ₆	F	D ₁	D ₂	E _{min} ±0,75	E _{max} ±0,75	L _{max} ±1,5	dynamic C		static C ₀	dynamic M _{xC}	static M _{xC0}	dynamic M _{yC} =M _{zC}	static M _{yC0} =M _{zC0}	
-	mm										kg	kg/m	N	Nm			
15	15	14	4,5	60	7,5	8,5	10	50	3 920	0,1	1,4	5 800	9 000	39	60	21	32
20	20	18	6	60	9,5	9,3	10	50	3 920	0,17	2,3	9 240	14 400	83	130	41	64
25	23	22	7	60	11	12,3	10	50	3 920	0,21	3,3	13 500	19 600	139	202	73	106
30	28	26	9	80	14	13,8	12	70	3 944	0,48	4,8	19 200	26 600	242	335	120	166
35	34	29	9	80	14	17	12	70	3 944	0,8	6,6	25 500	34 800	393	536	182	248

¹⁾ For detailed information on grease nipples, please refer to **page 70**.

²⁾ Dynamic load capacities and moments are based on a travel life of 100 km. Please refer to **page 15** for further details.

3.1.5 Carriage LLTHC ... U

Slim-line carriage, standard length, standard height.

Carriages from size 15 to 30 are also available with low friction S0 shield. Dimensions are the same as standard version. For designation, refer to **Ordering key carriages** (→ page 103).



Technical data

Size	Precision class	Designation ¹⁾ Preload class T0	T1	T2
-		-		
15	P5	LLTHC 15 U T0 P5	LLTHC 15 U T1 P5	LLTHC 15 U T2 P5
	P3	LLTHC 15 U T0 P3	LLTHC 15 U T1 P3	LLTHC 15 U T2 P3
	P1		LLTHC 15 U T1 P1	LLTHC 15 U T2 P1
20	P5	LLTHC 20 U T0 P5	LLTHC 20 U T1 P5	LLTHC 20 U T2 P5
	P3	LLTHC 20 U T0 P3	LLTHC 20 U T1 P3	LLTHC 20 U T2 P3
	P1		LLTHC 20 U T1 P1	LLTHC 20 U T2 P1
25	P5	LLTHC 25 U T0 P5	LLTHC 25 U T1 P5	LLTHC 25 U T2 P5
	P3	LLTHC 25 U T0 P3	LLTHC 25 U T1 P3	LLTHC 25 U T2 P3
	P1		LLTHC 25 U T1 P1	LLTHC 25 U T2 P1
30	P5	LLTHC 30 U T0 P5	LLTHC 30 U T1 P5	LLTHC 30 U T2 P5
	P3	LLTHC 30 U T0 P3	LLTHC 30 U T1 P3	LLTHC 30 U T2 P3
	P1		LLTHC 30 U T1 P1	LLTHC 30 U T2 P1
35	P5	LLTHC 35 U T0 P5	LLTHC 35 U T1 P5	LLTHC 35 U T2 P5
	P3	LLTHC 35 U T0 P3	LLTHC 35 U T1 P3	LLTHC 35 U T2 P3
	P1		LLTHC 35 U T1 P1	LLTHC 35 U T2 P1
45	P5	LLTHC 45 U T0 P5	LLTHC 45 U T1 P5	LLTHC 45 U T2 P5
	P3	LLTHC 45 U T0 P3	LLTHC 45 U T1 P3	LLTHC 45 U T2 P3
	P1		LLTHC 45 U T1 P1	LLTHC 45 U T2 P1

¹⁾ • Preferred range.

• Only available as system.

For designation, please refer to designation system.

Dimensional drawing

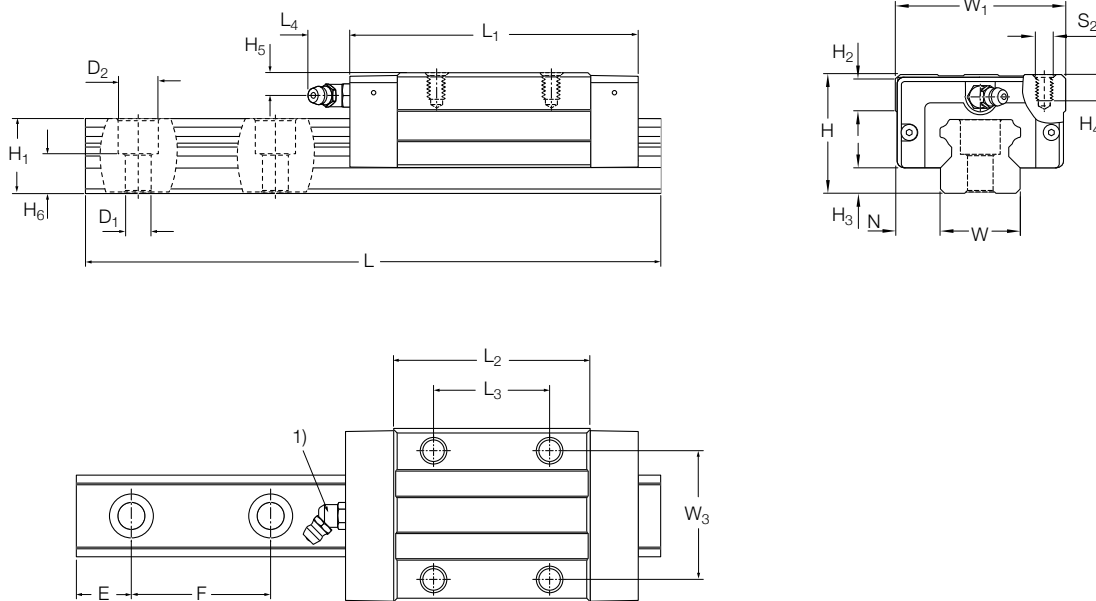

Size	Assembly dimensions				Carriage dimensions								
	W ₁ mm	N	H	H ₂	H ₃	L ₁	L ₂	L ₃	L ₄	W ₃	H ₄	H ₅	S ₂
15	34	9,5	24	4,8	4,6	63,3	40	26	4,3	26	4	4,3	M4×0,7
20	44	12	30	9,3	5	73,3	50	36	15	32	6,5	5,7	M5×0,8
25	48	12,5	36	9,6	7	84,4	57	35	16,6	35	6,5	6,5	M6×1,0
30	60	16	42	12,6	9	100,4	67,4	40	14,6	40	8,5	8	M8×1,25
35	70	18	48	12,3	9,5	114,4	77	50	14,6	50	10	8	M8×1,25
45	86	20,5	60	12,7	14	136,5	96	60	14,6	60	12	8,5	M10×1,5

Size	Rail dimensions				Weight					Load ratings ²⁾		Moments ²⁾					
	W	H ₁	H ₆	F	D ₁	D ₂	E _{min} ±0,75	E _{max} ±0,75	L _{max} ±1,5	carriage static	dynamic	static	dynamic	static	dynamic	static	
–	mm				mm					kg	kg/m	N	Nm				
15	15	14	8,5	60	4,5	7,5	10	50	3 920	0,17	1,4	8 400	15 400	56	103	49	90
20	20	18	9,3	60	6	9,5	10	50	3 920	0,26	2,3	12 400	24 550	112	221	90	179
25	23	22	12,3	60	7	11	10	50	3 920	0,38	3,3	18 800	30 700	194	316	155	254
30	28	26	13,8	80	9	14	12	70	3 944	0,81	4,8	26 100	41 900	329	528	256	410
35	34	29	17	80	9	14	12	70	3 944	1,2	6,6	34 700	54 650	535	842	388	611
45	45	38	20,8	105	14	20	16	90	3 917	2,1	11,3	59 200	91 100	1 215	1 869	825	1 270

¹⁾ For detailed information on grease nipples, please refer to page 70.

²⁾ Dynamic load capacities and moments are based on a travel life of 100 km. Please refer to page 15 for further details.

3.1.6 Carriage LLTHC ... LU

Slim-line carriage, extended length, standard height.

Carriages from size 25 to 30 are also available with low friction S0 shield. Dimensions are the same as standard version. For designation, refer to **Ordering key carriages** (→ page 105).



Technical data

Size	Precision class	Designation ¹⁾ Preload class T0	T1		T2	
–		–				
25	P5	LLTHC 25 LU T0 P5	LLTHC 25 LU T1 P5	LLTHC 25 LU T2 P5		
	P3	LLTHC 25 LU T0 P3	LLTHC 25 LU T1 P3	LLTHC 25 LU T2 P3		
	P1		LLTHC 25 LU T1 P1	LLTHC 25 LU T2 P1		
30	P5	LLTHC 30 LU T0 P5	LLTHC 30 LU T1 P5	LLTHC 30 LU T2 P5		
	P3	LLTHC 30 LU T0 P3	LLTHC 30 LU T1 P3	LLTHC 30 LU T2 P3		
	P1		LLTHC 30 LU T1 P1	LLTHC 30 LU T2 P1		
35	P5	LLTHC 35 LU T0 P5	LLTHC 35 LU T1 P5	LLTHC 35 LU T2 P5		
	P3	LLTHC 35 LU T0 P3	LLTHC 35 LU T1 P3	LLTHC 35 LU T2 P3		
	P1		LLTHC 35 LU T1 P1	LLTHC 35 LU T2 P1		
45	P5	LLTHC 45 LU T0 P5	LLTHC 45 LU T1 P5	LLTHC 45 LU T2 P5		
	P3	LLTHC 45 LU T0 P3	LLTHC 45 LU T1 P3	LLTHC 45 LU T2 P3		
	P1		LLTHC 45 LU T1 P1	LLTHC 45 LU T2 P1		

¹⁾ • Preferred range.

• Only available as system.

For designation, please refer to designation system.

Dimensional drawing

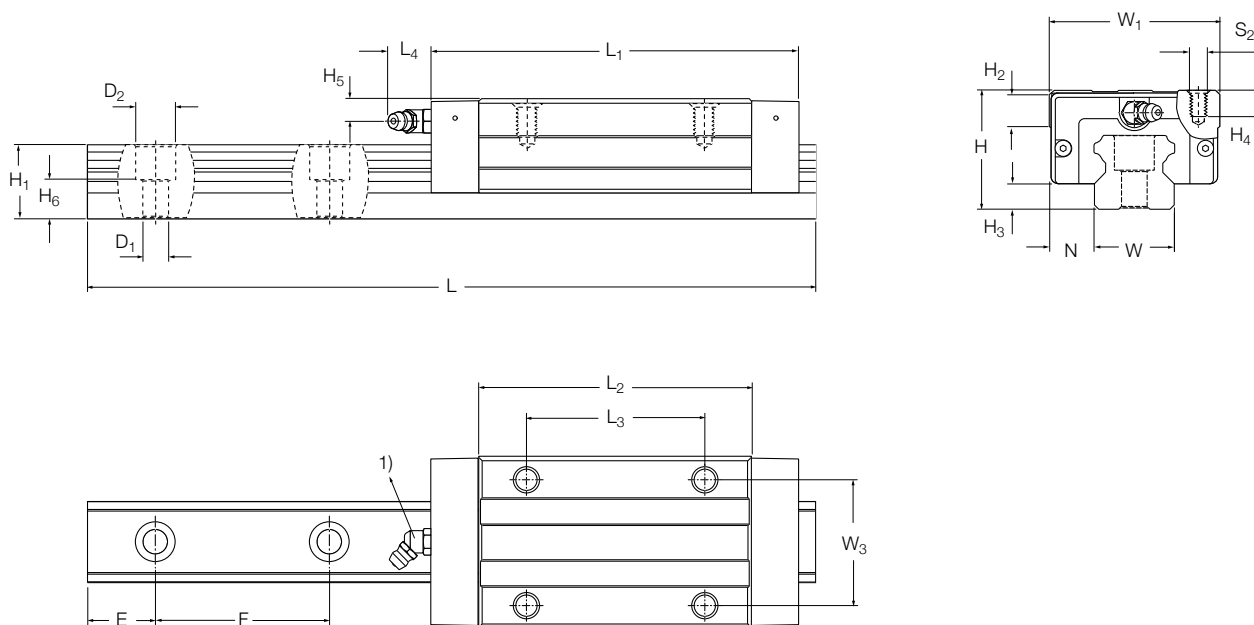

Size	Assembly dimensions					Carriage dimensions								
	W ₁ mm	N	H	H ₂	H ₃	L ₁	L ₂	L ₃	L ₄	W ₃	H ₄	H ₅	S ₂	
25	48	12,5	36	9,6	7	106,5	79,1	50	16,6	35	6,5	6,5	M6x1,0	
30	60	16	42	12,6	9	125,4	92,4	60	14,6	40	8,5	8	M8x1,25	
35	70	18	48	12,3	9,5	142,9	105,5	72	14,6	50	10	8	M8x1,25	
45	86	20,5	60	12,7	14	168,5	128	80	14,6	60	12	8,5	M10x1,5	

Size	Rail dimensions										Weight		Load ratings ²⁾		Moments ²⁾			
	W	H ₁	H ₆	F	D ₁	D ₂	E _{min} ±0,75	E _{max} ±0,75	L _{max} ±1,5	carriage rail		dynamic C	static C ₀	dynamic M _{xC}	static M _{xC₀}	dynamic M _{yC} =M _{zC}	static M _{yC₀} =M _{zC₀}	
-	mm										kg		N		Nm			
25	23	22	12,3	60	7	11	10	50	3 920	0,47	3,3	24 400	44 600	252	460	287	525	
30	28	26	13,8	80	9	14	12	70	3 944	0,82	4,8	33 900	60 800	428	767	466	836	
35	34	29	17	80	9	14	12	70	3 944	1,26	6,6	45 000	79 400	694	1 224	706	1 246	
45	45	38	20,8	105	14	20	16	90	3 917	2,11	11,3	72 400	121 400	1 485	2 491	1 376	2 308	

¹⁾ For detailed information on grease nipples, please refer to **page 70**.

²⁾ Dynamic load capacities and moments are based on a travel life of 100 km. Please refer to **page 15** for further details.

3.1.7 Carriage LLTHC ... R

Slim-line carriage, standard length, extended height.

Carriages from size 15 to 30 are also available with low friction S0 shield. Dimensions are the same as standard version. For designation, refer to **Ordering key carriages** (↳ page 103).



Technical data

Size	Precision class	Designation ¹⁾ Preload class T0	T1	T2
-		-		
15	P5	LLTHC 15 R T0 P5	LLTHC 15 R T1 P5	LLTHC 15 R T2 P5
	P3	LLTHC 15 R T0 P3	LLTHC 15 R T1 P3	LLTHC 15 R T2 P3
	P1		LLTHC 15 R T1 P1	LLTHC 15 R T2 P1
25	P5	LLTHC 25 R T0 P5	LLTHC 25 R T1 P5	LLTHC 25 R T2 P5
	P3	LLTHC 25 R T0 P3	LLTHC 25 R T1 P3	LLTHC 25 R T2 P3
	P1		LLTHC 25 R T1 P1	LLTHC 25 R T2 P1
30	P5	LLTHC 30 R T0 P5	LLTHC 30 R T1 P5	LLTHC 30 R T2 P5
	P3	LLTHC 30 R T0 P3	LLTHC 30 R T1 P3	LLTHC 30 R T2 P3
	P1		LLTHC 30 R T1 P1	LLTHC 30 R T2 P1
35	P5	LLTHC 35 R T0 P5	LLTHC 35 R T1 P5	LLTHC 35 R T2 P5
	P3	LLTHC 35 R T0 P3	LLTHC 35 R T1 P3	LLTHC 35 R T2 P3
	P1		LLTHC 35 R T1 P1	LLTHC 35 R T2 P1
45	P5	LLTHC 45 R T0 P5	LLTHC 45 R T1 P5	LLTHC 45 R T2 P5
	P3	LLTHC 45 R T0 P3	LLTHC 45 R T1 P3	LLTHC 45 R T2 P3
	P1		LLTHC 45 R T1 P1	LLTHC 45 R T2 P1

¹⁾ • Preferred range.

• Only available as system.

For designation, please refer to designation system.

Dimensional drawing

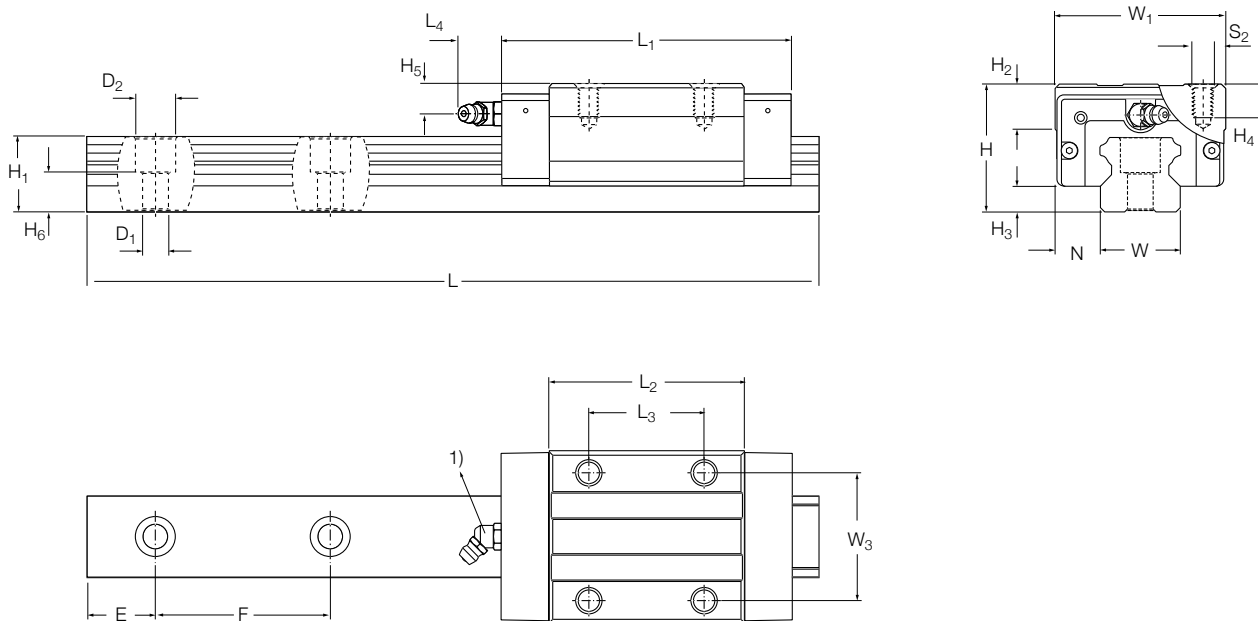

Size	Assembly dimensions					Carriage dimensions								
	W1	N	H	H2	H3	L1	L2	L3	L4	W3	H4	H5	S2	
-	mm													
15	34	9,5	28	8,8	4,6	63,3	40	26	15	26	7,5	8,3	M4x0,7	
25	48	12,5	40	13,6	7	84,4	57	35	16,6	35	10	10,5	M6x1,0	
30	60	16	45	15,6	9	100,4	67,4	40	14,6	40	11,2	11	M8x1,25	
35	70	18	55	19,3	9,5	114,4	77	50	14,6	50	17	15	M8x1,25	
45	86	20,5	70	22,7	14	136,5	96	60	14,6	60	20,5	18,5	M10x1,5	

Size	Rail dimensions									Weight		Load ratings ²⁾		Moments ²⁾			
	W	H ₁	H ₆	F	D ₁	D ₂	E _{min} ±0,75	E _{max} ±0,75	L _{max} ±1,5	carriage	rail	dynamic C	static C ₀	dynamic M _x C	static M _x C ₀	dynamic M _{yc} =M _{zc}	static M _{yc0} =M _{zc0}
-	mm									kg	kg/m	N		Nm			
15	15	14	8,5	60	4,5	7,5	10	50	3 920	0,19	1,4	8 400	15 400	56	103	49	90
25	23	22	12,3	60	7	11	10	50	3 920	0,45	3,3	18 800	30 700	194	316	155	254
30	28	26	13,8	80	9	14	12	70	3 944	0,91	4,8	26 100	41 900	329	528	256	410
35	34	29	17	80	9	14	12	70	3 944	1,5	6,6	34 700	54 650	535	842	388	611
45	45	38	20,8	105	14	20	16	90	3 917	2,3	11,3	59 200	91 100	1 215	1 869	825	1 270

¹⁾ For detailed information on grease nipples, please refer to page 70.

²⁾ Dynamic load capacities and moments are based on a travel life of 100 km. Please refer to page 15 for further details.

3.1.8 Carriage LLTHC ... LR

Slim-line carriage, extended length, extended height.

Carriages from size 20 to 30 are also available with low friction S0 shield. Dimensions are the same as standard version. For designation, refer to **Ordering key carriages** (↳ page 103).



Technical data

Size	Precision class	Designation ¹⁾		
		Preload class T0	T1	T2
–		–		
20	P5	LLTHC 20 LR T0 P5	LLTHC 20 LR T1 P5	LLTHC 20 LR T2 P5
	P3	LLTHC 20 LR T0 P3	LLTHC 20 LR T1 P3	LLTHC 20 LR T2 P3
	P1		LLTHC 20 LR T1 P1	LLTHC 20 LR T2 P1
25	P5	LLTHC 25 LR T0 P5	LLTHC 25 LR T1 P5	LLTHC 25 LR T2 P5
	P3	LLTHC 25 LR T0 P3	LLTHC 25 LR T1 P3	LLTHC 25 LR T2 P3
	P1		LLTHC 25 LR T1 P1	LLTHC 25 LR T2 P1
30	P5	LLTHC 30 LR T0 P5	LLTHC 30 LR T1 P5	LLTHC 30 LR T2 P5
	P3	LLTHC 30 LR T0 P3	LLTHC 30 LR T1 P3	LLTHC 30 LR T2 P3
	P1		LLTHC 30 LR T1 P1	LLTHC 30 LR T2 P1
35	P5	LLTHC 35 LR T0 P5	LLTHC 35 LR T1 P5	LLTHC 35 LR T2 P5
	P3	LLTHC 35 LR T0 P3	LLTHC 35 LR T1 P3	LLTHC 35 LR T2 P3
	P1		LLTHC 35 LR T1 P1	LLTHC 35 LR T2 P1
45	P5	LLTHC 45 LR T0 P5	LLTHC 45 LR T1 P5	LLTHC 45 LR T2 P5
	P3	LLTHC 45 LR T0 P3	LLTHC 45 LR T1 P3	LLTHC 45 LR T2 P3
	P1		LLTHC 45 LR T1 P1	LLTHC 45 LR T2 P1

¹⁾ • Preferred range,

• Only available as system.

For designation, please refer to designation system.

Dimensional drawing

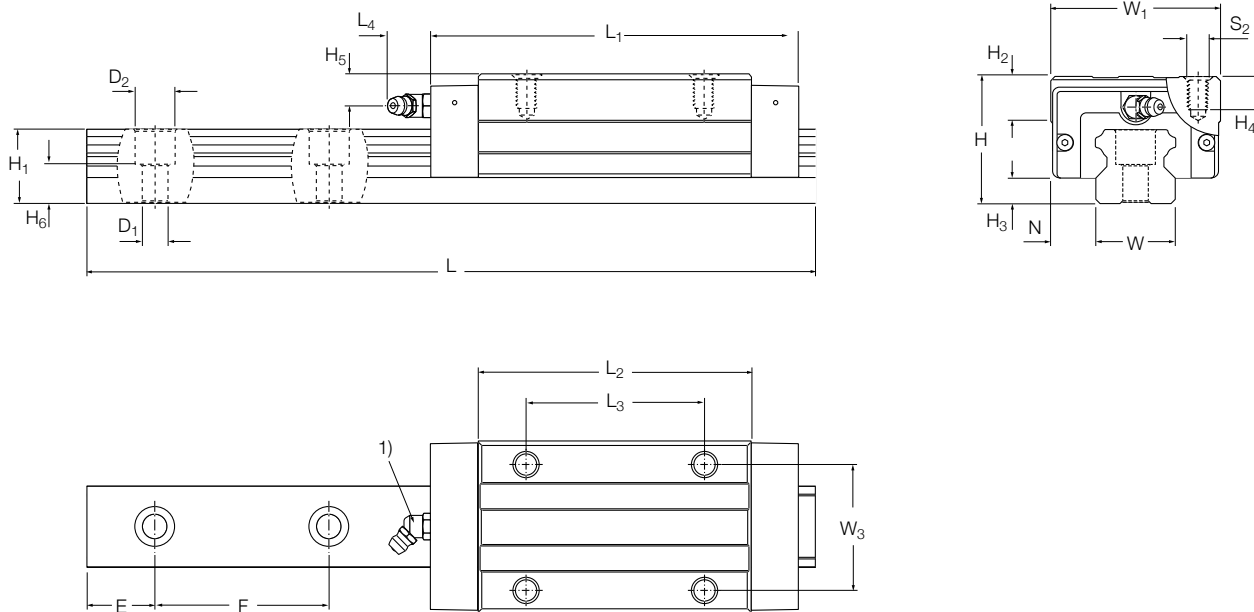

Size	Assembly dimensions					Carriage dimensions								
	W ₁ mm	N	H	H ₂	H ₃	L ₁	L ₂	L ₃	L ₄	W ₃	H ₄	H ₅	S ₂	
20	44	12	30	9,3	5	89,5	66,2	50	15	32	6,5	5,7	M5×0,8	
25	48	12,5	40	13,6	7	106,5	79,1	50	16,6	35	10	10,5	M6×1,0	
30	60	16	45	15,6	9	125,4	92,4	60	14,6	40	11,2	11	M8×1,25	
35	70	18	55	19,3	9,5	142,9	105,5	72	14,6	50	17	15	M8×1,25	
45	86	20,5	70	22,7	14	168,5	128	80	14,6	60	20,5	18,5	M10×1,5	

Size	Rail dimensions										Weight carriage rail kg	Load ratings ²⁾ dynamic C	static C ₀	Moments ²⁾			
	W	H ₁	H ₆	F	D ₁	D ₂	E _{min} ±0,75	E _{max} ±0,75	L _{max} ±1,5	dynamic M _{xc}				static M _{xc0}	dynamic M _{yc} =M _{zc}	static M _{yc0} =M _{zc0}	
–	mm										kg	kg/m	N	Nm			
20	20	18	9,3	60	6	9,5	10	50	3 920	0,47	2,3	15 200	32 700	137	295	150	322
25	23	22	12,3	60	7	11	10	50	3 920	0,56	3,3	24 400	44 600	252	460	287	525
30	28	26	13,8	80	9	14	12	70	3 944	1,2	4,8	33 900	60 800	428	767	466	836
35	34	29	17	80	9	14	12	70	3 944	1,9	6,6	45 000	79 400	694	1 224	706	1 246
45	45	38	20,8	105	14	20	16	90	3 917	2,8	11,3	72 400	121 400	1 485	2 491	1 376	2 308

¹⁾ For detailed information on grease nipples, please refer to **page 70**.

²⁾ Dynamic load capacities and moments are based on a travel life of 100 km. Please refer to **page 15** for further details.



3.2 Rail data

LLTHR rails

Supplied with protective plastic caps for mounting from above.

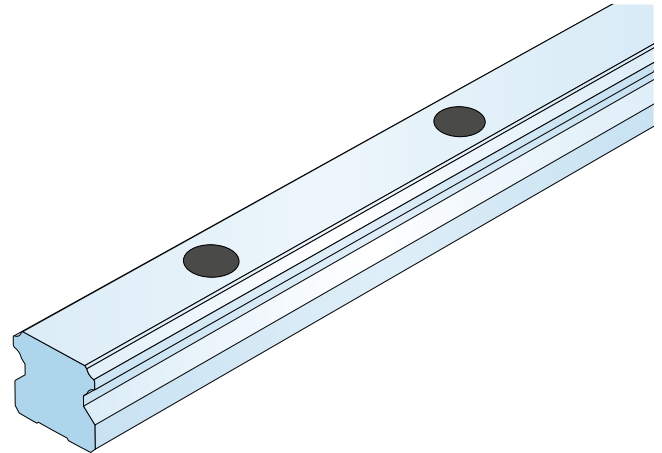

LLTHR ... D4 rails

With blind holes for mounting from below.

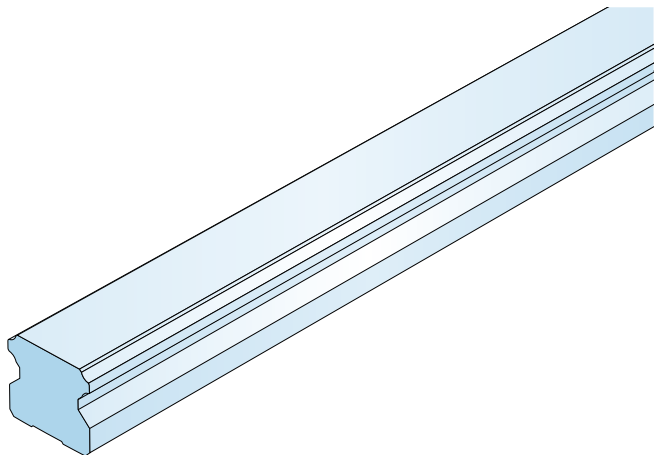

LLTHR ... D6 rails

Supplied with protective metal plugs for mounting from above.

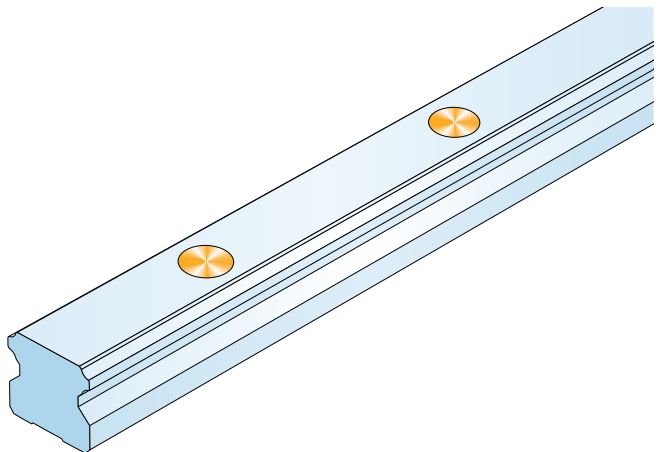

3.2.1 LLTHR rails

Rails are supplied with protective plastic caps for mounting from above. For designation, refer to **Ordering key rails** (→ page 104).

NOTE: If a rail length is required that exceeds the maximum length available, jointed rails can be ordered. These rails are manufactured so they match seamlessly to each other.



Technical data

Size	Precision class	Designation ¹⁾		Pitch F mm
		One-piece rail	Multi-piece rail	
–	–	–	–	–
15	P5	LLTHR 15 - ... P5	LLTHR 15 - ... P5 A	60
	P3	LLTHR 15 - ... P3	LLTHR 15 - ... P3 A	
	P1	LLTHR 15 - ... P1	LLTHR 15 - ... P1 A	
20	P5	LLTHR 20 - ... P5	LLTHR 20 - ... P5 A	60
	P3	LLTHR 20 - ... P3	LLTHR 20 - ... P3 A	
	P1	LLTHR 20 - ... P1	LLTHR 20 - ... P1 A	
25	P5	LLTHR 25 - ... P5	LLTHR 25 - ... P5 A	60
	P3	LLTHR 25 - ... P3	LLTHR 25 - ... P3 A	
	P1	LLTHR 25 - ... P1	LLTHR 25 - ... P1 A	
30	P5	LLTHR 30 - ... P5	LLTHR 30 - ... P5 A	80
	P3	LLTHR 30 - ... P3	LLTHR 30 - ... P3 A	
	P1	LLTHR 30 - ... P1	LLTHR 30 - ... P1 A	
35	P5	LLTHR 35 - ... P5	LLTHR 35 - ... P5 A	80
	P3	LLTHR 35 - ... P3	LLTHR 35 - ... P3 A	
	P1	LLTHR 35 - ... P1	LLTHR 35 - ... P1 A	
45	P5	LLTHR 45 - ... P5	LLTHR 45 - ... P5 A	105
	P3	LLTHR 45 - ... P3	LLTHR 45 - ... P3 A	
	P1	LLTHR 45 - ... P1	LLTHR 45 - ... P1 A	

¹⁾ • **Preferred range,**
 • Only available as system.
 By rail length in mm, e.g. LLTHR 15 -1000 P5

Dimensional drawing

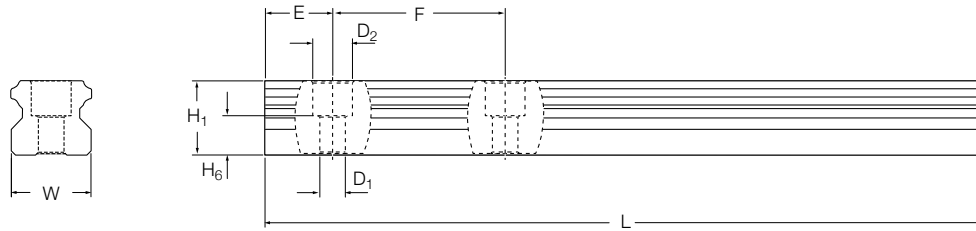

Size	Dimensions									Weight
	W	H ₁	H ₆	D ₁	D ₂	E _{min}	E _{max}	F	L _{max}	
-	mm									kg/m
15	15	14	8,5	4,5	7,5	10	50	60	3 920	1,4
20	20	18	9,3	6	9,5	10	50	60	3 920	2,3
25	23	22	12,3	7	11	10	50	60	3 920	3,3
30	28	26	13,8	9	14	12	70	80	3 944	4,8
35	34	29	17	9	14	12	70	80	3 944	6,6
45	45	38	20,8	14	20	16	90	105	3 917	11,3

The “E” dimension designates the distance from the rail end to centre of the first attachment hole. If no specific “E” dimension is provided by the customer with the order, the rails are produced according to the following formulae:

Calculation of number of attachment holes in rail guide

(1)
$$n_{\text{real}} = \frac{L}{F}$$

(2) Round down of n_{real} to n

(3) $n + 1 = z$

F = Distance of attachment holes

L = Rail length

n_{real} = Real calculation value number of hole distances

z = Number of attachment holes in rail

Determination of E dimension based on z

(4)
$$E_{\text{real}} = \frac{L - F(z - 1)}{2}$$

E_{real} = Real calculation value for E-dimension

E_{min} = Minimum E-dimension according to catalogue

Comparison with catalogue value of E_{min}

(4.1) If $E_{\text{real}} \geq E_{\text{min}}$
Usage of E_{real} from **formula 4**

(4.2) If $E_{\text{real}} < E_{\text{min}}$
Calculation of E_{real} according to **formula 5**

(5)
$$E_{\text{real}} = \frac{L - F(z - 2)}{2}$$

3.2.2 LLTHR rails ... D4 rails

For mounting from below. For designation, refer to **Ordering key rails** (↳ **page 104**).

NOTE: If a rail length is required that exceeds the maximum length available, jointed rails can be ordered. These rails are manufactured so they match seamlessly to each other.



Technical data

Standard rail size	Precision class	Designation ¹⁾		Pitch F mm
		One-piece rail	Multi-piece rail	
–	–	–	–	–
15	P5	LLTHR 15 - ... P5 D4	LLTHR 15 - ... P5 A D4	60
	P3	LLTHR 15 - ... P3 D4	LLTHR 15 - ... P3 A D4	
	P1	LLTHR 15 - ... P1 D4	LLTHR 15 - ... P1 A D4	
20	P5	LLTHR 20 - ... P5 D4	LLTHR 20 - ... P5 A D4	60
	P3	LLTHR 20 - ... P3 D4	LLTHR 20 - ... P3 A D4	
	P1	LLTHR 20 - ... P1 D4	LLTHR 20 - ... P1 A D4	
25	P5	LLTHR 25 - ... P5 D4	LLTHR 25 - ... P5 A D4	60
	P3	LLTHR 25 - ... P3 D4	LLTHR 25 - ... P3 A D4	
	P1	LLTHR 25 - ... P1 D4	LLTHR 25 - ... P1 A D4	
30	P5	LLTHR 30 - ... P5 D4	LLTHR 30 - ... P5 A D4	80
	P3	LLTHR 30 - ... P3 D4	LLTHR 30 - ... P3 A D4	
	P1	LLTHR 30 - ... P1 D4	LLTHR 30 - ... P1 A D4	
35	P5	LLTHR 35 - ... P5 D4	LLTHR 35 - ... P5 A D4	80
	P3	LLTHR 35 - ... P3 D4	LLTHR 35 - ... P3 A D4	
	P1	LLTHR 35 - ... P1 D4	LLTHR 35 - ... P1 A D4	
45	P5	LLTHR 45 - ... P5 D4	LLTHR 45 - ... P5 A D4	105
	P3	LLTHR 45 - ... P3 D4	LLTHR 45 - ... P3 A D4	
	P1	LLTHR 45 - ... P1 D4	LLTHR 45 - ... P1 A D4	

¹⁾ • Preferred range,

• Only available as system.

replace "... " by rail length in mm, e. g. LLTHR 15 - 1000 P5 D4

Dimensional drawing

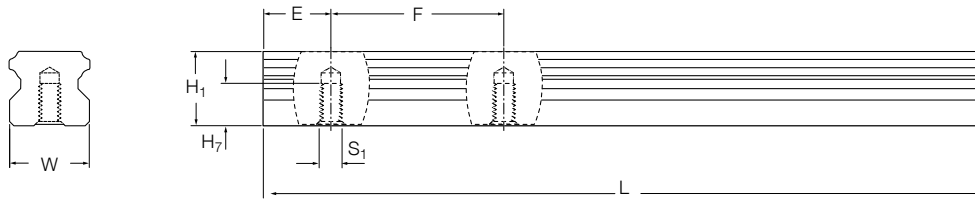

Size	Dimensions								Weight
	W	H ₁	H ₇	S ₁	E _{min}	E _{max}	F	L _{max}	
–	mm								kg/m
15	15	14	8	M5	10	50	60	3 920	1,4
20	20	18	10	M6	10	50	60	3 920	2,4
25	23	22	12	M6	10	50	60	3 920	3,4
30	28	26	15	M8	12	70	80	3 944	5,0
35	34	29	17	M8	12	70	80	3 944	6,8
45	45	38	24	M12	16	90	105	3 917	11,8

The “E” dimension designates the distance from the rail end to centre of the first attachment hole. If no specific “E” dimension is provided by the customer with the order, the rails are produced according to the following formulae:

Calculation of number of attachment holes in rail guide

$$(1) \quad n_{\text{real}} = \frac{L}{F}$$

(2) Round down of n_{real} to n

$$(3) \quad n + 1 = z$$

F = Distance of attachment holes

L = Rail length

n_{real} = Real calculation value for number of hole distances

z = Number of attachment holes in rail

Determination of E dimension based on z

$$(4) \quad E_{\text{real}} = \frac{L - F(z - 1)}{2}$$

E_{real} = Real calculation value for E-dimension

E_{min} = Minimum E-dimension according to catalogue

Comparison with catalogue value of E_{min}

(4.1) If $E_{\text{real}} \geq E_{\text{min}}$
Usage of E_{real} from **formula 4**

(4.2) If $E_{\text{real}} < E_{\text{min}}$
Calculation of E_{real} according to **formula 5**

$$(5) \quad E_{\text{real}} = \frac{L - F(z - 2)}{2}$$

3.2.3 LLTHR ... D6 rails

Rails are supplied with protective metal caps for mounting from above. For designation, refer to

Ordering key rails (→ page 104).

Protective metal plugs ensure that no residues of dirt, swarf, cooling water and other contaminants remain in the area of the attachment holes. After insertion, these plugs align flush with the surface of the profile rail guide to provide effective wiping. The use of additional scraper plates in combination with these protective metal plugs is an option which will further enhance protection (→ page 62).

NOTE: If a rail length is required that exceeds the maximum length available, jointed rails can be ordered. These rails are manufactured so they match seamlessly to each other.



Size-specific mounting tools from Ewellix are needed for installing the protective metal plugs. Please refer to **page 104** for ordering the mounting tool.

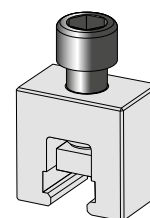

Mounting tool for installing protective metal plugs

Technical data

Standard rail size	Precision class	Designation ¹⁾		Pitch F mm
		One-piece rail	Multi-piece rail	
–	–	–	–	–
25	P5	LLTHR 25 - ... P5 D6	LLTHR 25 - ... P5 A D6	60
	P3	LLTHR 25 - ... P3 D6	LLTHR 25 - ... P3 A D6	
	P1	LLTHR 25 - ... P1 D6	LLTHR 25 - ... P1 A D6	
30	P5	LLTHR 30 - ... P5 D6	LLTHR 30 - ... P5 A D6	80
	P3	LLTHR 30 - ... P3 D6	LLTHR 30 - ... P3 A D6	
	P1	LLTHR 30 - ... P1 D6	LLTHR 30 - ... P1 A D6	
35	P5	LLTHR 35 - ... P5 D6	LLTHR 35 - ... P5 A D6	80
	P3	LLTHR 35 - ... P3 D6	LLTHR 35 - ... P3 A D6	
	P1	LLTHR 35 - ... P1 D6	LLTHR 35 - ... P1 A D6	
45	P5	LLTHR 45 - ... P5 D6	LLTHR 45 - ... P5 A D6	105
	P3	LLTHR 45 - ... P3 D6	LLTHR 45 - ... P3 A D6	
	P1	LLTHR 45 - ... P1 D6	LLTHR 45 - ... P1 A D6	

¹⁾ • Preferred range,

• Only available as system.

replace “...” by rail length in mm, e. g. LLTHR 15 - 1000 P5 D4

Dimensional drawing

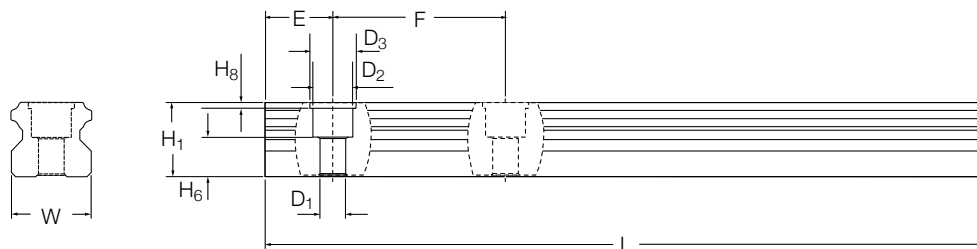

Size	Dimensions											Weight
	W	H ₁	H ₆	H ₈	D ₁	D ₂	D ₃	E _{min}	E _{max}	F	L _{max}	
-	mm											kg/m
25	23	22	12,3	2,2	7	11	13	10	50	60	3 920	3,3
30	28	26	13,8	2,2	9	14	16	12	70	80	3 944	4,8
35	34	29	17	2,2	9	14	16	12	70	80	3 944	6,6
45	45	38	20,8	2,2	14	20	25	16	90	105	3 917	11,3

The “E” dimension designates the distance from the rail end to centre of the first attachment hole. If no specific “E” dimension is provided by the customer with the order, the rails are produced according to the following formulae:

Calculation of number of attachment holes in rail guide

(1) $n_{real} = \frac{L}{F}$

(2) Round down of n_{real} to n

(3) $n + 1 = z$

F = Distance of attachment holes

L = Rail length

n_{real} = Real calculation value for number of hole distances

z = Number of attachment holes in rail

Determination of E dimension based on z

(4) $E_{real} = \frac{L - F(z - 1)}{2}$

E_{real} = Real calculation value for E-dimension

E_{min} = Minimum E-dimension according to catalogue

Comparison with catalogue value of E_{min}

(4.1) If $E_{real} \geq E_{min}$
Usage of E_{real} from **formula 4**

(4.2) If $E_{real} < E_{min}$
Calculation of E_{real} according to **formula 5**

(5) $E_{real} = \frac{L - F(z - 2)}{2}$

3.3 Accessories

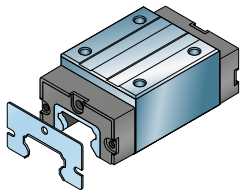
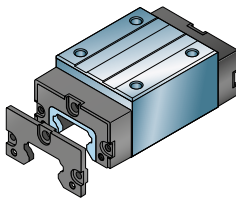
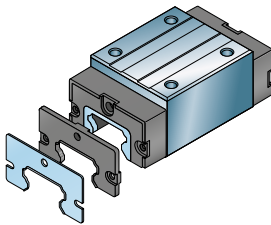
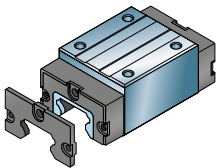
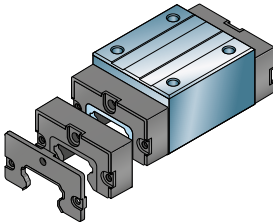
Accessories	Illustration ¹⁾	Purpose
Item name		
Scraper plate LLTHZ ... S1		Scraper plates are spring-steel, non-contact components. They protect the front seal from coarse contaminants or hot metal chips.
Additional front seal LLTHZ ... S7		Additional front seals are contact seals that can be attached to the carriage end faces. They are single-lip seals consisting of special heavy-duty material and offer additional protection against liquids and smaller contaminants. An additional front seal, in combination with carriages equipped with a low friction S0 shield, result in a sealed system with lower friction.
Seal kit LLTHZ ... S3		The seal kit consists of a metal scraper and an additional front seal. It is intended for applications involving exposure to coarse and fine dirt as well as liquids.
Low friction shield LLTHZ ... S0		The low friction shield has no contact with the rail. It replaces the standard front seal and results in a reduced friction force. Since the sealing function is not in place at the front ends of the carriage, the lubrication interval is reduced. The low friction shield is available for carriages from size 15 to 30.
Lube element LLTHZ ... S6		The lube element is designed to enhance the service life of a profile rail guide system. It provides an additional lubrication reservoir which consists of foam filled with oil in permanent contact with the raceways at the rail. By capillary attraction of the foam, the oil is constantly dosed in the correct amount. The ball elements roll through the applied oil film, whereby the optimal tribological conditions are maintained. The lube element is mounted on the end plate. The use of the originally delivered front seal keeps the dirt outside and the lubricant inside the carriage.

¹⁾ Appearance can vary slightly depending on the size

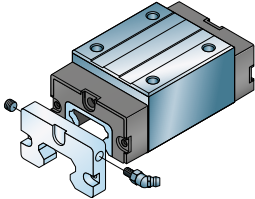
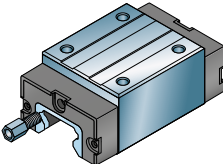
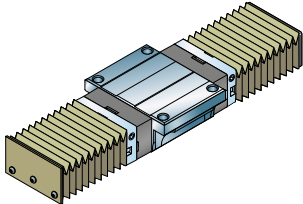
Accessories		
Item name	Illustration ¹⁾	Purpose
Adapter plate LLTHZ ... PL		<p>Adapter plates provide a side lubrication point, either for a grease nipple or for central lubrication systems. The interface of the adapter plate is the same on both sides. The adapter plate can be mounted on both end sides of the carriage. Usually only one adapter plate is used per carriage. Please note that this accessory is also part of the bellow sets.</p>
Lubrication connector LLTHZ ... VN UA		<p>The lubrication connector is used to provide an interface for central lubrication systems. The lubrication connector can be mounted on both end sides of the carriage. Usually only one lubrication connector is used per carriage. Please note that the lubrication connector cannot be used in combination with additional seals (scraper plate, additional front seal, seal kit and adapter plate).</p>
Bellows LLTHZ ... B		<p>Bellows protect the entire system against solid and liquid contaminants from above. They are suitable for highly contaminated environments like machining centres in the woodworking and metals industries.</p>

¹⁾ Appearance can vary slightly depending on the size

3.3.1 Scraper plate (S1)

- Material: spring steel according to DIN EN 10088
- Appearance: black
- Designed with a specified maximum gap of 0,2 to 0,3 mm

Mounting

Mounting screws and grease nipple are included. When mounting, be sure there is an even space between the rail and scraper plate.

NOTE: Can be ordered in combination with an additional front seal as a kit. For designation, refer to **Ordering key accessories** (↳ page 104).

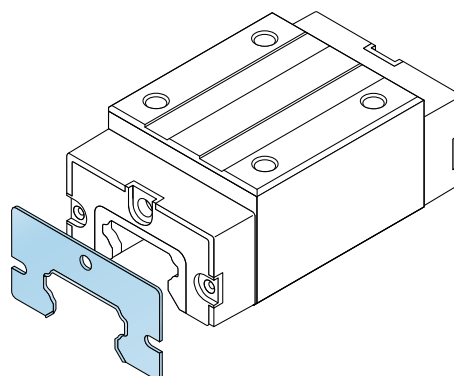

Appearance can vary slightly depending on the size.

Dimensional drawing

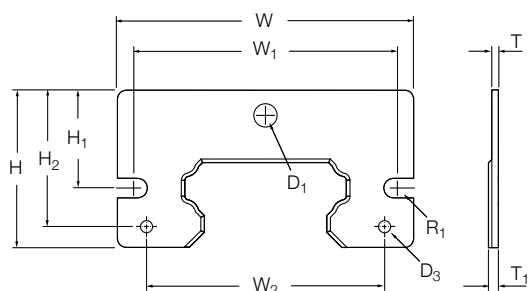

Size	Part designation	Dimensions										
		D ₁ mm	D ₃	R ₁	W	W ₁	W ₂	H	H ₁	H ₂	T	T ₁
15	LLTHZ 15 S1	3,6	–	1,75	31,6	25,8	–	18,5	12	–	1,5	2,3
20	LLTHZ 20 S1	5,5	–	1,75	42,6	35	–	24,2	14,8	–	1,5	2,3
25	LLTHZ 25 S1	5,5	–	2,25	46,6	39,6	–	27,7	16,8	–	1,5	2,3
30	LLTHZ 30 S1	6,5	–	1,75	57	50	–	30,4	19,3	–	1,5	2,3
35	LLTHZ 35 S1	6,5	3,4	2,25	67,3	59,2	52	36,3	22,1	30,1	1,5	2,3
45	LLTHZ 45 S1	6,5	3,4	2,75	83,3	72	67	44,2	27,5	38,3	1,5	2,3

3.3.2 Additional front seal (S7)

- Material: Elastomer
- Design: single-lip seal

Mounting

Mounting screws and grease nipple are included.

NOTE: Can be ordered in combination with a scraper plate as a kit. For designation, refer to **Ordering key accessories** (→ page 104).

An additional front seal in combination with carriages equipped with low friction S0 shield results in a sealed system with lower friction.

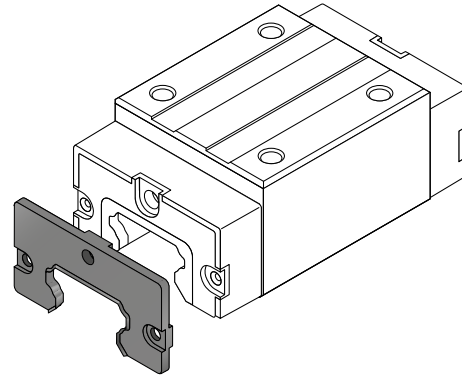

Appearance can vary slightly depending on the size.

Dimensional drawing

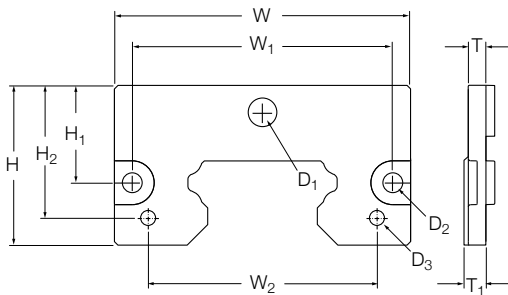

Size	Part designation	Dimensions											
		D ₁ mm	D ₂	D ₃	W	W ₁	W ₂	H	H ₁	H ₂	T	T ₁	
–	–												
15	LLTHZ 15 S7	3,6	3,4	–	31,6	25,8	–	18,5	12	–	3	4	
20	LLTHZ 20 S7	5,5	3,4	–	42,6	35	–	24,2	14,8	–	3	4	
25	LLTHZ 25 S7	5,5	4,5	–	46,6	39,6	–	27,7	16,8	–	3	4	
30	LLTHZ 30 S7	6,5	3,4	–	57,9	50	–	31,5	19,3	–	4	5	
35	LLTHZ 35 S7	6,5	4,5	3,4	67,3	59,2	52	36,3	22,1	30,1	4	5	
45	LLTHZ 45 S7	6,5	5,5	3,4	83,3	72	67	44,2	27,5	38,3	4	5	

3.3.3 Seal kit (S3)

The seal kit consists of the following components:

- Scraper plate
- Additional front seal

Mounting

Mounting screws and grease nipple are included. For designation, refer to **Ordering key accessories** (→ page 104).

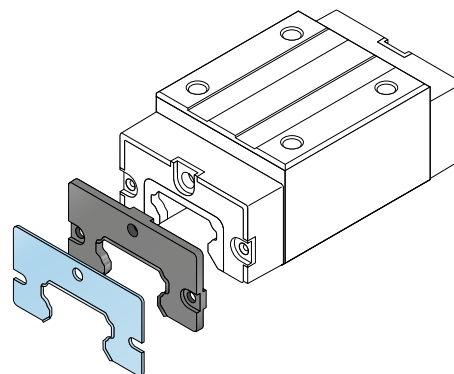

Appearance can vary slightly depending on the size.

Dimensional drawing

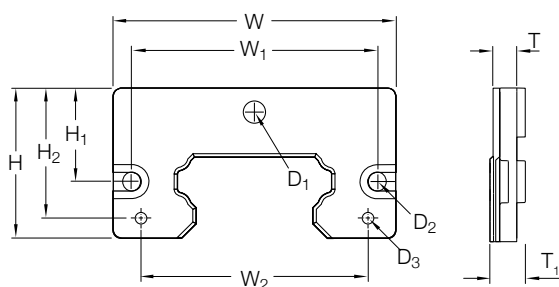

Size	Part designation	Dimensions										
		D ₁ mm	D ₂	D ₃	W	W ₁	W ₂	H	H ₁	H ₂	T	T ₁
-	-											
15	LLTHZ 15 S3	3,6	3,4	-	31,6	25,8	-	18,5	12	-	4,5	5,3
20	LLTHZ 20 S3	5,5	3,4	-	42,6	35	-	24,2	14,8	-	4,5	5,3
25	LLTHZ 25 S3	5,5	4,5	-	46,6	39,6	-	27,7	16,8	-	4,5	5,3
30	LLTHZ 30 S3	6,5	3,4	-	57,9	50	-	31,5	19,3	-	5,5	6,3
35	LLTHZ 35 S3	6,5	4,5	3,4	67,3	59,2	52	36,3	22,1	30,1	5,5	6,3
45	LLTHZ 45 S3	6,5	5,5	3,4	83,3	72	67	44,2	27,5	38,3	5,5	6,3

3.3.4 Low friction shield (S0)

- Material: PA6.6
- Size: 15 to 30
- Non-contact component

Mounting

The low friction shield (S0) replaces the standard front seal. The dimensions for the mounting screws and the grease nipple remain unchanged.

NOTE: A low friction shield (S0) combined with the additional front seal (S7) results in a sealed system with lower friction.

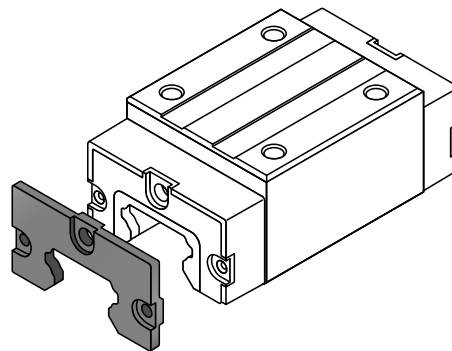

Appearance can vary slightly depending on the size.

Dimensional drawing

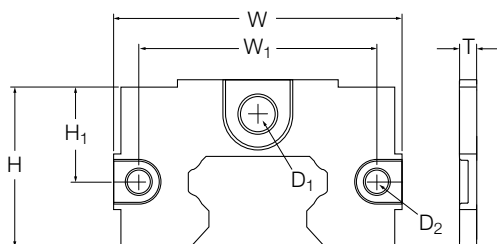

Size	Part designation	Dimensions						
		D ₁ mm	D ₂	W	W ₁	H	H ₁	T
15	LLTHZ 15 S0	3,4	3,4	31,3	25,8	18,3	11,2	2
20	LLTHZ 20 S0	5,4	3,4	42,4	35	24,1	13,8	2
25	LLTHZ 25 S0	5,4	4,4	46,4	39,6	27,1	15,7	2,5
30	LLTHZ 30 S0	6,3	3,4	57,2	50	31,3	18,1	4

3.3.5 Lube element (S6)

Benefits

- Longer relubrication intervals
- Less maintenance costs
- Easy mounting and replacement by clicking onto/over the rail
- Applicable for horizontal and vertical mounting
- Can be combined and ordered with standard LLT accessories, such as seal kit
- Suitable for all carriage types of size 15 to 35
- Delivered ready to mount with all needed parts and filled with oil

Technical data

The relubrication interval of 5 000 km with lube element is valid for all sizes and under following pre-conditions:

- Load ratio: $F_m \leq 0,3C$
- Speed: ≤ 1 m/s
- Temperature: +10 up to +50 °C
- Mounting: One lube element per lubricated carriage

The lube element is filled with high quality oil which has the right viscosity and is compatible with the grease of the carriage. Other oil types can be validated by Ewellix on request. The lube element housing is made of POM. By mounting a grease nipple to the lube element, the carriage can be regularly greased. It is not possible to refill the lube element. For ideal function the lube element should be replaced after 5

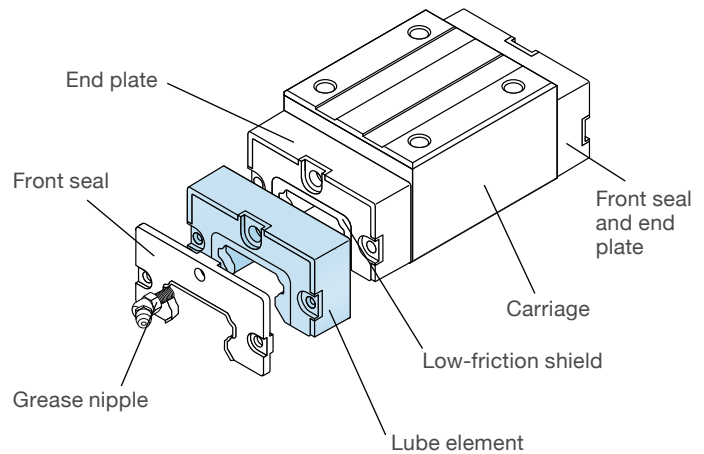

000 km of travel distance, unless regular greasing is given through the grease nipple.

Because of the contact of the foam to the raceways of the rail, a slight increase of friction can occur.

A lube set LLTHZ S6 consists of one low-friction shield (S0), one lube element and two screws. The permissible storage temperature is -15 up to +50 °C. The maximum storage duration in a warehouse is two years under the above mentioned conditions.

In case of different pre-conditions in the application, the performance may differ. Please contact Ewellix for further information.

Dimensional drawing

The carriage length increases by value T_2 , when a lube element is used

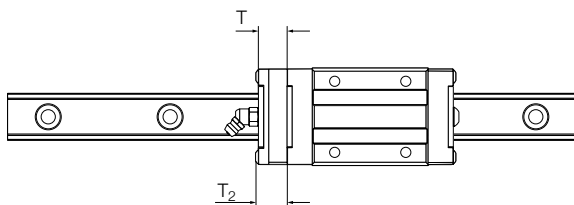

Size	T	T ₂	Tightening torque of mounting screws
-	mm	(including screw head) mm	Nm
15	10,5	11,0	0,20
20	12,5	13,0	0,20
25	14,5	15,0	0,20
30	14,5	15,0	0,38
35	17,5	18,0	0,38

3.3.6 Adapter plate (PL)

- Material: Aluminium
- Appearance: Natural aluminium, non-anodized

Mounting

Mounting screws, sealing ring and grease nipple are included. For designation, refer to **Ordering key accessories** (↳ page 104).

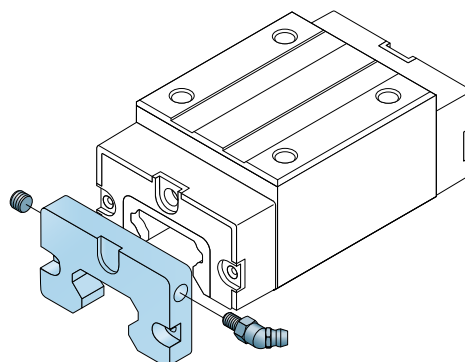

Appearance can vary slightly depending on the size.

Dimensional drawing

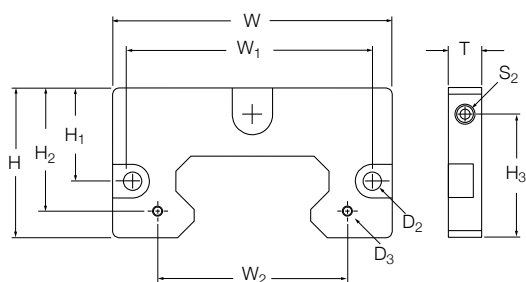

Size	Part designation	Dimensions										
		S ₂ mm	D ₂	D ₃	W	W ₁	W ₂	H	H ₁	H ₂	H ₃	T
15	LLTHZ 15 PL	M5×0,8	3,4	M2×0,4	32	25,8	20	18,9	12,2	16,4	13,7	10
20	LLTHZ 20 PL	M5×0,8	3,4	M3×0,5	43	35	28	24,5	15	20	17,5	10
25	LLTHZ 25 PL	M5×0,8	4,5	M3×0,5	47	39,6	32	28	17	23	22,5	10
30	LLTHZ 30 PL	M6×1,0	3,5	M3×0,5	58,5	50	38	32	19,5	26	25	10
35	LLTHZ 35 PL	M6×1,0	4,5	M3×0,5	68	59,2	45	37	22,5	29,5	30	10
45	LLTHZ 45 PL	M6×1,0	5,5	M3×0,5	84	72	57	45	28	37	37	10

3.3.7 Lubrication connectors

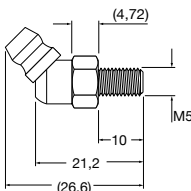
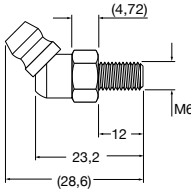
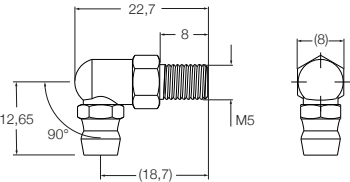
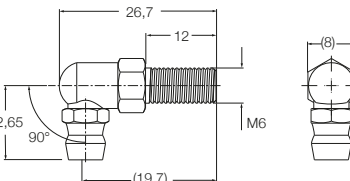
Ordering key	Material	Size	Description
	Steel, coated	15	<ol style="list-style-type: none"> Standard grease nipple for size 15. It cannot be used in combination with additional seals. According to standard JIS 1575:2000 One grease nipple for manual relubrication is supplied along with the carriage, while the opposite side is secured by a set screw.
	Steel, coated	20	<ol style="list-style-type: none"> Standard grease nipple for size 20. It cannot be used in combination with additional seals. According to standard JIS 1575:2000 One grease nipple for manual relubrication is supplied along with the carriage, while the opposite side is secured by a set screw.
	Steel, coated	25	<ol style="list-style-type: none"> Standard grease nipple for size 25. It cannot be used in combination with additional seals. According to standard JIS 1575:2000 One grease nipple for manual relubrication is supplied along with the carriage, while the opposite side is secured by a set screw.
	Steel, coated	30/35/45	<ol style="list-style-type: none"> Standard grease nipple for size 30/35/45. It cannot be used in combination with additional seals. According to standard JIS 1575:2000 One grease nipple for manual relubrication is supplied along with the carriage, while the opposite side is secured by a set screw.
	Steel, coated	20	<ol style="list-style-type: none"> 90 degree grease nipple for size 20 It cannot be used in combination with additional seals. The lubrication connector is used to provide an interface for central lubrication systems
	Steel, coated	30/35/45	<ol style="list-style-type: none"> 90 degree grease nipple for size 30/35/45 It cannot be used in combination with additional seals. The lubrication connector is used to provide an interface for central lubrication systems
	Steel, coated	20	<ol style="list-style-type: none"> Straight grease nipple for size 20 It cannot be used in combination with additional seals. The lubrication connector is used to provide an interface for central lubrication systems

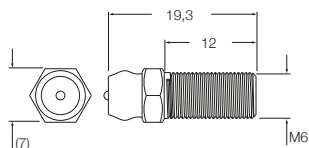

VN-M6-12	Steel, coated	30/35/45	<ol style="list-style-type: none"> 1. Straight grease nipple for size 30/35/45 2. It cannot be used in combination with additional seals. 3. The lubrication connector is used to provide an interface for central lubrication systems
----------	---------------	----------	---

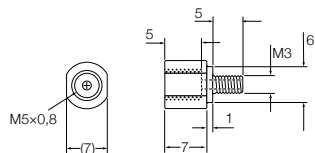

VN-UA-M3-05-01	Steel, coated	15	<ol style="list-style-type: none"> 1. Straight lubrication connectors for size 15 2. It cannot be used in combination with additional seals. 3. The lubrication connector is used to provide an interface for central lubrication systems
----------------	---------------	----	--

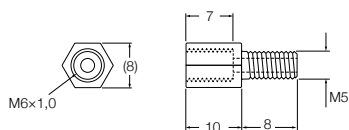

VN-UA-M5-08-01	Steel, coated	20	<ol style="list-style-type: none"> 1. Straight lubrication connectors for size 20 2. It cannot be used in combination with additional seals. 3. The lubrication connector is used to provide an interface for central lubrication systems
----------------	---------------	----	--

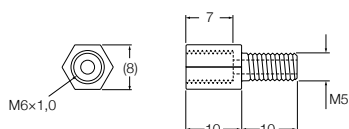

VN-UA-M5-10-01	Steel, coated	25	<ol style="list-style-type: none"> 1. Straight lubrication connectors for size 25 2. It cannot be used in combination with additional seals. 3. The lubrication connector is used to provide an interface for central lubrication systems
----------------	---------------	----	--

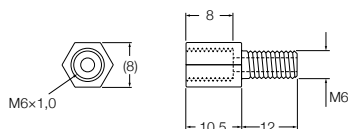

VN-UA-M6-12-01	Steel, coated	30/35/45	<ol style="list-style-type: none"> 1. Straight lubrication connectors for size 30/35/45 2. It cannot be used in combination with additional seals. 3. The lubrication connector is used to provide an interface for central lubrication systems
----------------	---------------	----------	--

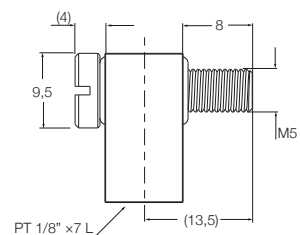

VN-M5-8-OIL	Brass	20	<ol style="list-style-type: none"> 1. 90 degree lubrication connectors for size 20 2. It cannot be used in combination with additional seals. 3. The lubrication connector is used to provide an interface for central lubrication systems
-------------	-------	----	---

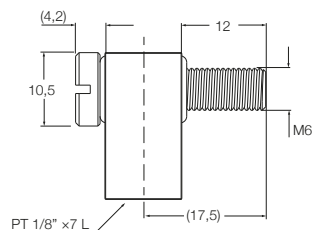

LLTHP30-0G-02	Brass	30/35/45	<ol style="list-style-type: none"> 1. 90 degree lubrication connectors for size 30/35/45 2. It cannot be used in combination with additional seals. 3. The lubrication connector is used to provide an interface for central lubrication systems
---------------	-------	----------	---

3.3.8 Bellows

Material and Temperature

Temperature resistance

Temperature resistance $t_{max} = 90\text{ °C}$.

During continuous operation, the permissible operating temperature is between -20 and 80 °C . Special materials for higher temperature resistance are available.

Special material LAS: available for size 15–30. Temperature limit is 160 °C for a very short period.

Special material WEL: available for size 35–45. Temperature limit is 260 °C for a very short period.

For all applications, please note the maximum temperature range for LLT systems (→ page 19).

Material

Bellows are made of polyester fabric with a polyurethane coating. Adapter plates are made of aluminium.

Bellows parts

Bellows kit contents (→ fig. 1)

1. Adapter plate
2. Grease nipple
3. Sealing ring
4. Set screw
5. Mounting screws
6. Bellows with all plates

NOTE: Rail ends must be prepared with threaded holes.

NOTE: The bellows is only available in Europe.

Mounting

The bellows are delivered unmounted with mounting screws and necessary plates.

NOTE: Prior to mounting, the grease nipples on the carriage must be removed.

For bellow arrangement type 2 (→ table. 1), the end faces of the rails have to be equipped with threaded attachment holes.

Fig. 1
Delivery scope

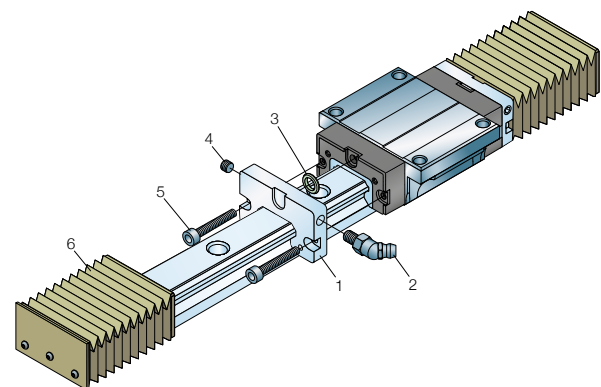
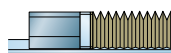

Table 1

Bellows designations ¹⁾



Size	Type 2 with adapter plates for the carriage and end plate for the rail	Type 4 with two adapter plates for the carriages	Type 9 loose bellows (spare part)
–	–	–	–
15	LLTHZ 15 B2 ..	LLTHZ 15 B4 ..	LLTHZ 15 .. B9
20	LLTHZ 20 B2 ..	LLTHZ 20 B4 ..	LLTHZ 20 .. B9
25	LLTHZ 25 B2 ..	LLTHZ 25 B4 ..	LLTHZ 25 .. B9
30	LLTHZ 30 B2 ..	LLTHZ 30 B4 ..	LLTHZ 30 .. B9
35	LLTHZ 35 B2 ..	LLTHZ 35 B4 ..	LLTHZ 35 .. B9
45	LLTHZ 45 B2 ..	LLTHZ 45 B4 ..	LLTHZ 45 .. B9

¹⁾ Replace “..” by number of folds per bellows.

Calculation of bellow and rail

Calculation of the bellows type 2¹⁾

$$n = \frac{L - L_A}{W_{4 \min} + W_{4 \max}} + F$$

See **table 2** and **3**

Calculation of the rail length

$$L = (n - F) (W_{4 \min} + W_{4 \max}) + L_A$$

$$L_{\min} = n W_{4 \min}$$

$$L_{\max} = n W_{4 \max}$$

$$\text{Stroke} = n S_F$$

rail length < 500 mm F=2
 500 mm < rail length < 1 000 mm F=3
 rail length > 1000 mm F=4

where

- L_A = Carriage length L_1 (please refer to the dimension tables of the carriages) plus 2x10 mm for the adapter plates.
- L = Rail length [mm]
- L_{\max} = Bellow stretched
- L_{\min} = Bellow pushed together
- n = Total number of folds per carriage side
- S_F = Stroke per fold
- S_F = $W_{4 \max} - W_{4 \min}$ [mm]
- Stroke = Stroke [mm]
- W_4 = Maximum and minimum extension per fold

¹⁾ Calculation for maximum possible stroke. Calculation of bellow type 4 on request, specifications on stroke length required.

Table 2

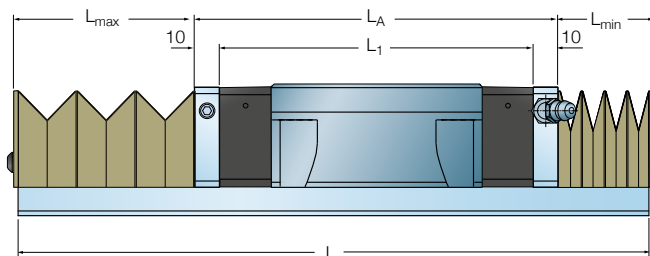
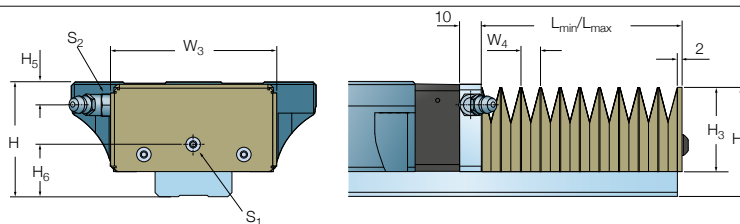

Table 3

Dimensions of the bellows



Size	Dimensions								STD	LAS	WEL		
	W_3 mm	$H^{1)}$	$H^{2)}$	H_3	H_4	H_5	H_6	S_1			S_2	$W_{4 \min}$	$W_{4 \max}^{3)}$
-													
15	32	24	28	18,9	23,5	3,8	8,8	M4 x 8	M5	2,5	3	-	9,6
20	43	30	30	24,5	29,5	5,2	12	M4 x 8	M5	2,5	3	-	12
25	47	36	40	28	35	5,5	15,5	M4 x 8	M5	2,5	3	-	12
30	58	42	45	32	41	7	19	M4 x 8	M6	2,5	3	-	16,9
35	68	48	55	37	47	6,5	21,5	M4 x 8	M6	2,5	-	4	21
45	84	60	70	45	59	7,5	28,5	M4 x 8	M6	2,5	-	4	25,2

¹⁾ For carriages of type SA, A, LA, SU, U, LU

²⁾ For carriages of type R, LR

³⁾ $W_{4 \max}$ valid for all types of material (standard material, LAS, WEL)

4

**Mounting
instruction and
maintenance**



4.1 Design rules

The following mounting instructions are applicable to all carriage types.

To maintain the high precision of Ewellix LLT profile rail guides, the carriages must be handled carefully during transport and mounting.

To provide protection during transport, storage and assembly, LLT rails and carriages are coated with a corrosion inhibiting compound. This compound does not need to be removed if the recommended lubricants are used.

4.1.1 Typical mounting examples

Rails

Each rail has ground reference edges on both sides.

Options for securing the rails laterally (→ fig. 1)

1. Stop edges
2. Retaining strips

Rails that are not laterally fixed must be installed straight and parallel. Ewellix recommends using a support strip to maintain the rail's position during installation.

NOTE: Rail ends must be chamfered to prevent seal damage during installation. If two rails are to be joined, do not chamfer either of the mating ends.

Guideline values for the permissible lateral loads for unsupported rails are listed on **page 77, table 3**.

Carriage

Each carriage has one ground reference side (please refer to dimension H2 in the drawings of the carriages) (→ **page 39**).

Options for securing the carriages laterally (→ fig. 1)

3. Stop edges
4. Retaining strips

NOTE: If mounted correctly, the carriage should move easily on the rail when pushed.

During assembly, secure the carriage to prevent it from falling. Guideline values for the permissible lateral loads for unsupported carriages are shown in **page 77, table 3**.

Fig. 1
Mounting with laterally fixed rails and carriages

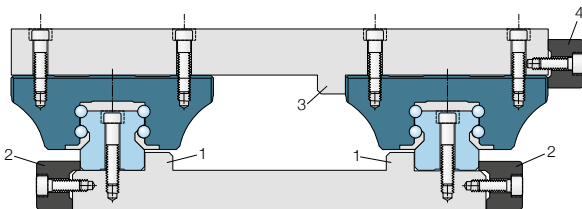
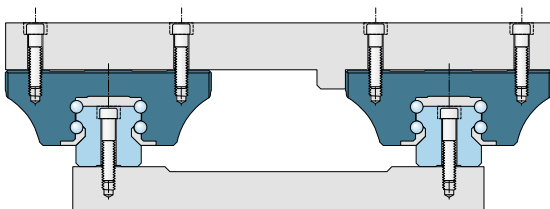

Fig. 2
Mounting without lateral rail support



4.1.2 Interface design, screw sizes and tightening torques

- Flange-type carriages can be fastened from above (↳ fig. 3) or below (↳ fig. 4)
- Slim-type carriages can be fastened from above (↳ fig. 5)
- Rails can be fastened from above (↳ fig. 4 and 5) or below (↳ fig. 3, rail type LLTHR ... D4).

Fig. 3

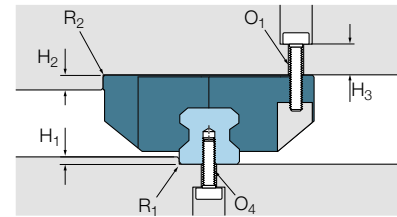

Fig. 4

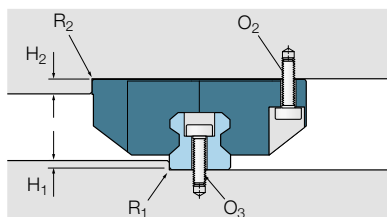

Fig. 5

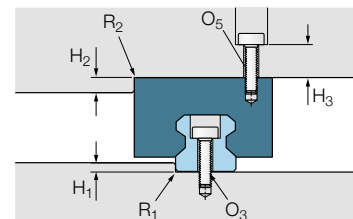

Table 1

Stop edges, corner radii and screw sizes

Size	Dimensions						Screw				
	H ₁ min	H ₁ max	R ₁ max	H ₂	R ₂ max	H ₃ ¹⁾	O ₁ ISO 4762 4 Piece	O ₂	Rail		
–	mm										
15	2,5	3,5	0,4	4	0,6	6	M5 x 12	M4 x 12	M4 x 20	M5 x 12	M4 x 12
20	2,5	4,0	0,6	5	0,6	9	M6 x 16	M5 x 16	M5 x 25	M6 x 16	M5 x 16
25	3,0	5,0	0,8	5	0,8	10	M8 x 20	M6 x 18	M6 x 30	M6 x 20	M6 x 18
30	3,0	5,0	0,8	6	0,8	10	M10 x 20	M8 x 20	M8 x 30	M8 x 20	M8 x 20
35	3,5	6,0	0,8	6	0,8	13	M10 x 25	M8 x 25	M8 x 35	M8 x 25	M8 x 25
45	4,5	8,0	0,8	8	0,8	14	M12 x 30	M10 x 30	M12 x 45	M12 x 30	M10 x 30

¹⁾ The stated values are only recommendations

²⁾ For carriage type SU + SA, two screws are sufficient to withstand the maximum load .

Table 2

Tightening torques for mounting screws

	Screw strength class	Screw					
		M4 Nm	M5	M6	M8	M10	M12
for counterparts made out of steel or cast iron	8,8	2,9	5,75	9,9	24	48	83
	12,9	4,95	9,7	16,5	40	81	140
for counterparts made out of aluminium	8,8	1,93	3,83	6,6	16	32	55
	12,9	3,3	6,47	11	27	54	93

Table 3

Dimensions and guide values for permissible lateral forces without additional lateral support (↳ fig. 2)

Carriages	Screw strength class	Carriages				
		O ₁	O ₂	O ₅	O ₃	O ₄
A, U, R	8,8	23 % C	11 % C	11 % C	6 % C	6 % C
	12,9	35 % C	18 % C	18 % C	10 % C	10 % C
LA, LU, LR	8,8	18 % C	8 % C	8 % C	4 % C	4 % C
	12,9	26 % C	14 % C	14 % C	7 % C	7 % C
SA, SU	8,8	12 % C	8 % C	8 % C	9 % C	9 % C
	12,9	21 % C	13 % C	13 % C	15 % C	15 % C

4.1.3 Position tolerances for attachment holes

The attachment holes of all surrounding parts have to match the tolerances shown in figure 6 and 7.

Fig. 6

Attachment structure for carriages

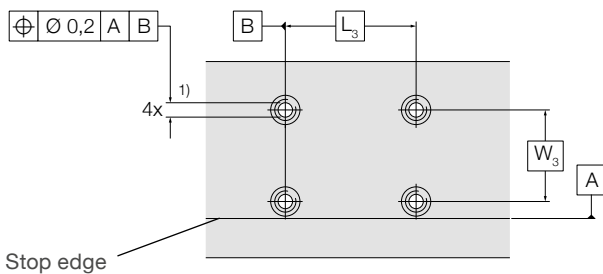

1) in case of carriage types SA, SU: 2x

Fig. 7

Attachment structure for profile rail guides

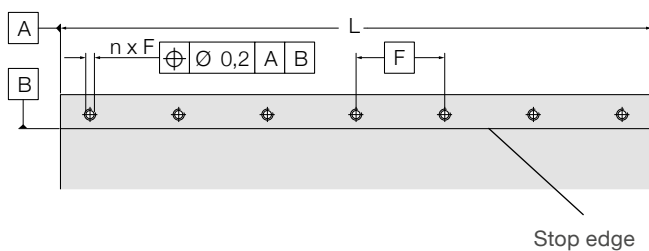

4.1.4 Permissible height deviation

The values for height deviation are applicable for all carriage types.

If the values for height deviation S_1 (↪ table 4) and S_2 (↪ table 5) are within the specified range, the service life of the rail guide system will not be influenced.

For permissible height deviation in the lateral direction (↪ table 4)

$$S_1 = d Y$$

where

S_1 = Permissible height deviation [mm]

d = Distance between the rails [mm]

Y = Calculation factor lateral direction

NOTE: The height tolerance of H for the carriages has to be taken into account. For additional information on height tolerance, see pages 17, table 2. If the difference $S_1 - 2 \times \text{tolerance } H < 0$, a new product selection is necessary (other preload, precision).

For permissible height deviation in the longitudinal direction (↪ table 5)

$$S_2 = c X$$

where

S_2 = Permissible height deviation [mm]

c = Distance between the carriages [mm]

X = Calculation factor longitudinal direction

NOTE: The maximum difference ΔH for the carriages has to be taken into account. For additional information, pages 17, table 2. If the difference $S_2 - \Delta H < 0$, a new product selection is necessary (other preload, precision).

Table 4

Permissible height deviation in lateral direction

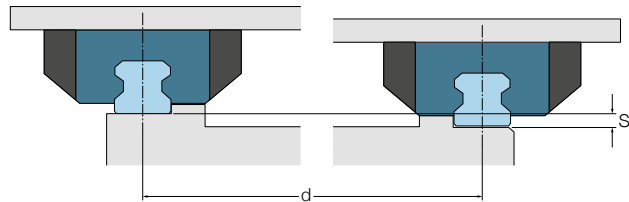

Calculation factor	Preload		
	T0	T1 Preload (2 % C)	T2 Preload (8 % C)
Y	$5,2 \times 10^{-4}$	$3,4 \times 10^{-4}$	$2,0 \times 10^{-4}$
Y (SA and SU carriage types)	$6,2 \times 10^{-4}$	$4,1 \times 10^{-4}$	–

Table 5

Permissible height deviation in longitudinal direction

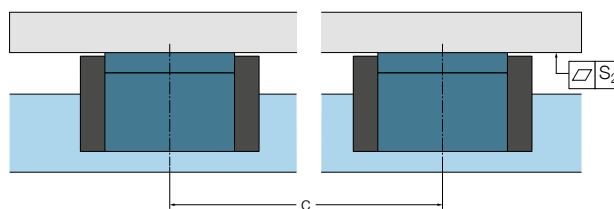

Calculation factor	Carriage length		
	short	normal	long
X	$6,6 \times 10^{-5}$	$4,7 \times 10^{-5}$	$3,3 \times 10^{-5}$

4.1.5 Parallelism

The parallelism of mounted rails is measured on the rails and the carriages. The values for the deviation in parallelism P_a are applicable to all carriage types.

Deviation in parallelism P_a increases the internal load. If the values are within the specified range in **table 6**, the service life of the profile rail guide system will not be influenced.

For typical applications, the mounting surface can be slightly resilient.

However, for high-precision applications, the mounting surface must be rigid and the values in the table have to be cut in half.

Table 6

Deviation in parallelism P_a

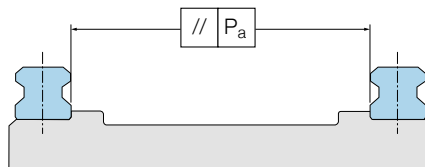

Size	Preload class		
	T0	T1 (2 % C)	T2 (8 % C)
–			
15	0,030	0,018	0,010
20	0,036	0,022	0,012
25	0,038	0,024	0,014
30	0,042	0,028	0,018
35	0,046	0,030	0,020
45	0,056	0,038	0,024
Carriage type SA + SU			
15	0,036	0,022	–
20	0,044	0,026	–
25	0,046	0,028	–
30	0,050	0,034	–
35	0,056	0,036	–

4.2 Mounting profile rail guides

4.2.1 Packaging (Shipment)

Profile rails and carriages are delivered in their own packaging. Unwrap these components carefully and remove the foam from the carriage. Do not recycle the packaging until the installation is complete. The packaging can be used to protect the components from damage during the mounting process.

4.2.2 Mounting the carriages

Screw in the grease nipple on the desired end plate and adjust the direction with the right washer (different thickness). Be sure that the ends of the rail are chamfered and deburred to avoid damaging the front seals or internal components. Apply a small amount of oil or grease to chamfers and the front seal of the carriage. Slide the carriage straight and carefully onto the profile rail, avoiding any misalignment.

4.2.3 Preparation

The threaded holes on the base plate must be first prepared according to the rail size.

Make sure that the contact surfaces are flat and free of any damage or burrs. Use an oil stone to smooth them if necessary (↳ **fig. 8**). Check the stop edges for dimensional and position precision and inspect the corner radii (↳ **page 76, table 1**).

Clean the contact surfaces thoroughly. Coat them with a thin coat of light oil to prevent corrosion.

Make sure that the rails, carriages, base plate, mounting plate and fastening screws all have the same temperature during installation.

Remove the corrosion inhibiting compound from the rail or carriage surfaces that are in contact with other parts. Then apply a thin coat of light oil to these surfaces. Be sure that all drilled and tapped holes are clean and free of debris prior to mounting.

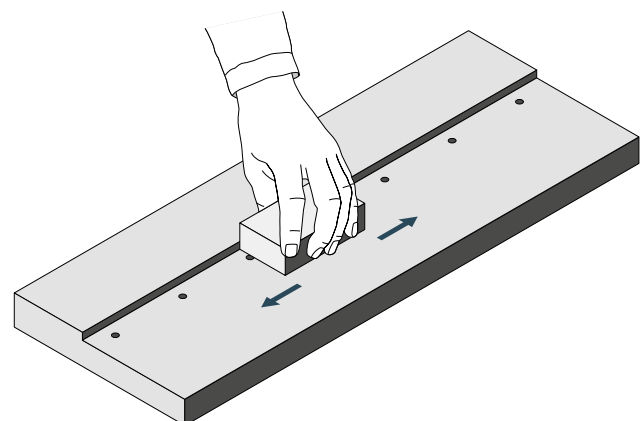

Fig. 8

4.2.4 Mounting the master rail

1. Place the profile rail gently onto the base plate.
2. Insert the screws, making sure that they are unobstructed, e.g. the mounting holes are properly aligned.
3. Partially tighten the screws so that the rail is still loose.
4. Push the rail against the stop edge (↳ **fig. 9**). The stop edge can be directly machined in the mounting surface or an external/mobile support strip that is only there for mounting. If necessary, hold the rail in place with a retaining strip (↳ **4.2.6 Mounting a retaining strip, page 84**). In cases where no lateral support is provided, use an external reference surface (↳ **fig. 10**) or a straight edge for alignment.
5. Using a torque wrench, tighten the centre mounting screw. Then, tighten the remaining screws using an alternating pattern (↳ **fig. 11**). Torque values are listed in **table 2, page 76**.
6. Check the parallelism of the fastened master rail to the specific reference. Result should be better than values in **table 6, page 79**.

Fig. 9

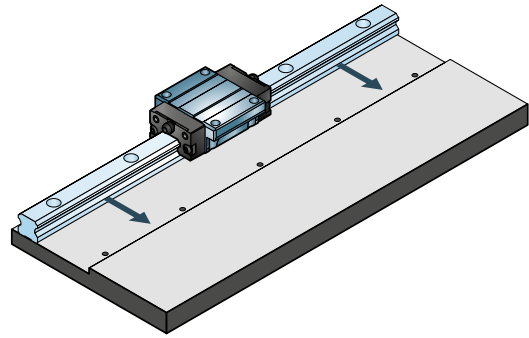

Fig. 10

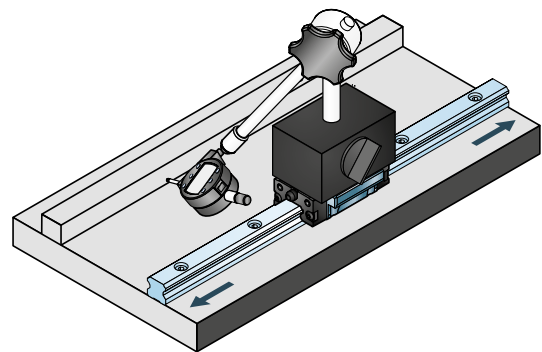
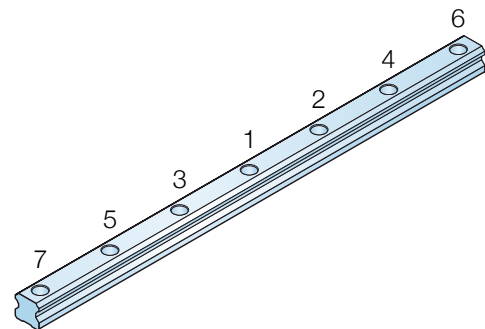

Fig. 11



4.2.5 Parallel alignment of subsidiary rail

The already aligned and fastened rail is defined as the master rail. Depending on the base plate design, there are several options for mounting subsidiary rails. Please choose the suitable option listed below.

Option I

Mounting with two stop edges on the base plate

If stop edges are provided on both sides of the base plate (→ fig. 12), please proceed as described above in

3.4 Mounting the master rail.

Option II

Mounting with two stop edges on the mounting plate

If there is no stop edge for the subsidiary rail on the base plate, the second rail can be aligned using a mounting plate with two stop edges.

1. Push in the carriage against the stop edge of the mounting plate (→ fig. 13).
2. Using a torque wrench, tighten the mounting screws to the designated value (→ table 2, page 76).
3. Place the subsidiary rail into position on the base plate.
4. Insert the screws, making sure that they are unobstructed, e.g. the mounting holes are properly aligned. (→ fig. 14).
5. Partially tighten the screws so that the rail is still loose.
6. Slide the mounting plate with the already fastened carriages onto the rails and move it over the full stroke (→ fig. 15).
7. Starting at one end of the rail, pre-tighten the rail screws to approximately 1/3 of their torque value. To maintain parallelism, be sure that the carriage is very close to the screws being tightened. (→ fig. 16).

Double-check for parallelism by running the carriages along their full stroke. Then, using a torque wrench, tighten the centre mounting screw. Tighten the remaining screws using the alternating pattern (→ fig.11, page 81). Torque values are listed in table 2, page 76.

NOTE: The resulting parallelism has to be according the values in table 6, page 79.

Fig. 12

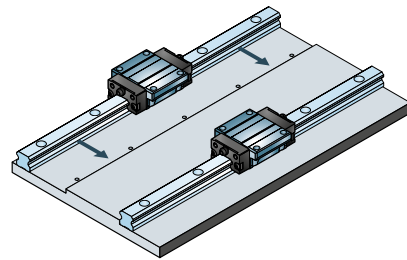

Fig.13

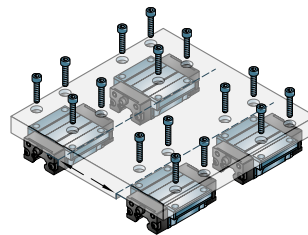

Fig.14

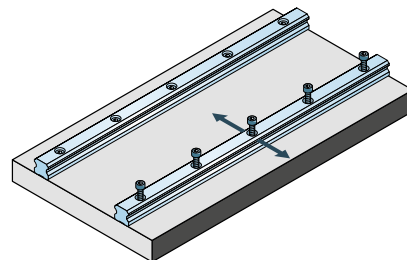

Fig. 15

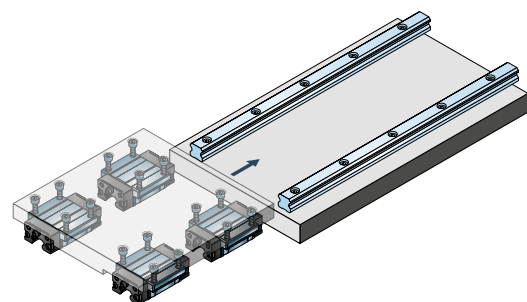
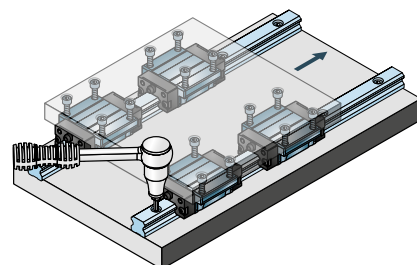

Fig. 16



Option III

Mounting with no stop edges

If there are no stop edges for the subsidiary rail on the base plate and no stop edges for the carriages on the mounting plate, then proceed as follows:

1. Place the subsidiary rail onto the base plate.
2. Insert the screws, making sure that they are unobstructed, e.g. the mounting holes are properly aligned (↳ **fig. 17**).
3. Partially tighten the screws so that the rail is still loose.
4. Slide a carriage onto the mounted master rail and affix a dial indicator to the top of the carriage. Place the tip of the indicator at the center of the ground reference edge of the subsidiary rail (↳ **fig. 18**).

Do the alignment and pre-fasten the screws with $\frac{1}{3}$ torque (↳ **fig. 19**).

5. Tighten all rail screws, beginning from the center, alternating to the ends (↳ **fig. 11 page 81**), with designated torque (↳ **table 2, page 76**) by using a torque wrench. Double check the parallelism along the full stroke.

NOTE: The resulting parallelism has to be according the values in **table 6, page 79**.

Fig.17

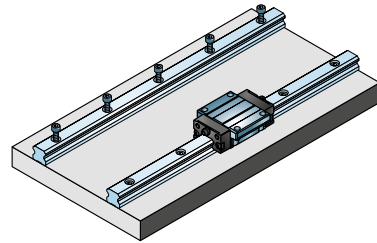

Fig.18

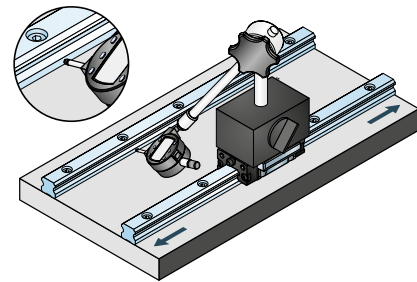
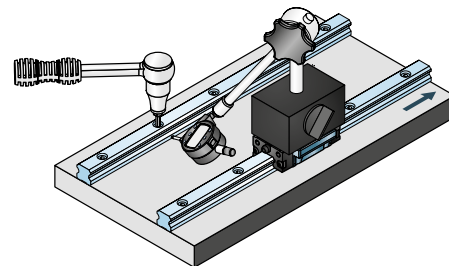

Fig. 19



4.2.6 Mounting a retaining strip

Profile rail guides can also be mounted without a retaining strip. However, guides are recommended because they absorb lateral forces and reduce the effort to straighten the rails. By using a retaining strip, the load capacity does not have to be reduced as shown on **page 77, table 3**. For details, refer to **pages 75 to 79**.

Before the retaining strips can be mounted, be sure that all screws are in place and slightly tightened.

1. Tighten the retaining strip screws (→ **fig. 20**) with a torque wrench.
2. Then, tighten the rail/carriage screws with a torque wrench. For permitted torque values, see **page 76, table 2**. Dimensions of the retaining strip, screws and distance between the screw holes depend on each specific customer case.

Check the straightness of the rail with a dial indicator by using a straight edge or an external reference edge (→ **page 81, fig. 10**).

4.2.7 Mounting jointed rails

Jointed rails are generally used when the longest rail length available (approximately 4 000 mm) is insufficient. When joining rails, Ewellix recommends grinding the base plate and stop edge which will significantly improve raceway alignment. As always, the bottom-side and the reference-edge of the rail are used for alignment. Do not use the top of the rail as a reference surface.

If the base plate does not have a stop edge, use clamps and a straight-edge during the entire installation process so that the rail being installed does not move out of position.

Make sure that the jointed rails are well aligned. The gap between two jointed rails should not exceed 20 µm. All rail sections are numbered continuously and close to the joint to avoid mounting errors (→ **fig. 21**).

Before using the system, move the carriage over the rail joints. There should be no perceptible difference in terms of noise or resistance. If there is a difference, please repeat the mounting process.

Fig. 20

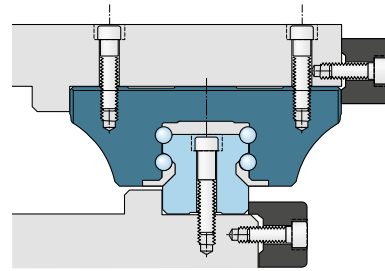
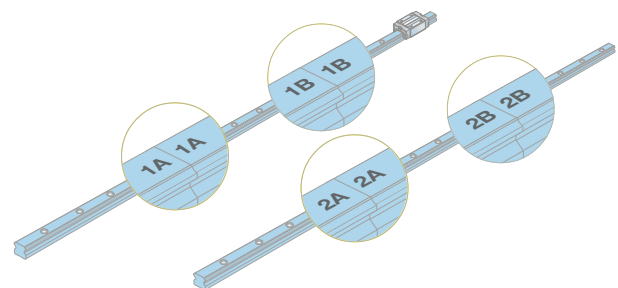

Fig. 21



4.2.8 Installing plastic caps

The plastic caps supplied with each rail guide must be installed flush with the rail surface.

NOTE: Caps sticking above the rail surface can damage the seal, generate debris and reduce the service life of the rail guide system. Caps that are sunk below the surface of the rail can collect dirt.

To install the caps, use a rubber mallet and a soft, e.g. plastic or aluminium, flat transition piece. Avoid sharp edges that could damage the rail (→ **fig. 22**).

Fig. 22

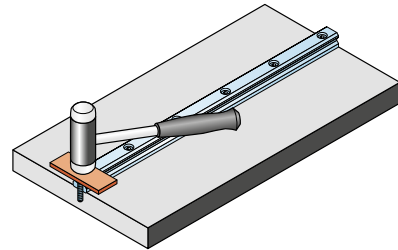

4.2.9 Installing metal plugs

1. Slide the mounting tool (→ **fig. 23**) onto the rail (→ **fig. 24**). Slide the mounting tool onto the rail, but remove all brass chips from the press block in advance.
2. Match the center of the mounting tool with the center of the metal plug, then use a hexagonal wrench to tighten the bolt (→ **fig. 25**). Stop tightening the bolt when the plug is flush with the rail surface.

Do not overtighten the bolt. 5–10 Nm is sufficient. Repeat this step for the remaining metal plugs.

Important: Before pressing in the plug and during plug alignment, make sure the top surface of the plug is parallel to the top surface of the rail.

After pressing the plugs into the rail, check that they are all flush with the rail surface. Then clean the rail to remove any debris.

With fastened rails the plugs have to be destroyed for removal.

Fig. 23

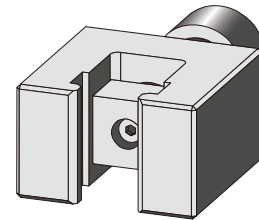

Fig. 24

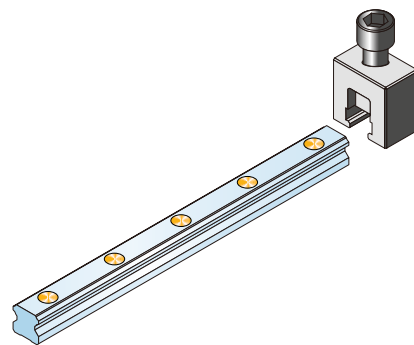
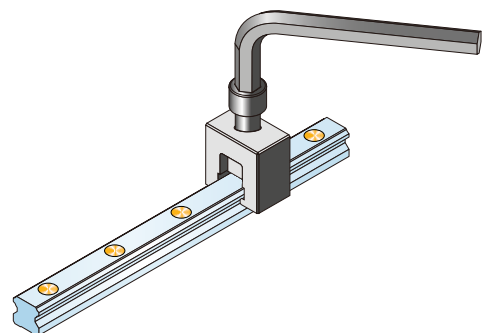

Fig. 25



4.3 Mounting accessories

4.3.1 Mounting the scraper plate (S1)

1. Remove the grease nipple (b) and washers (c.1 and c.2), or the set screw (a) (↳ fig. 26).
2. Remove the mounting screws (d)
3. Put the washers for mounting screws (6) into the fixation hole on each side.
4. Attach the metal scraper plate (5) onto the end plate, and position it accurately against the latter.
5. Install the mounting screws (4)
6. Install the grease nipple (2) and washers (3.1 and 3.2) if necessary.
7. If a grease nipple is not required, install a set screw (1) instead.

Fig. 26

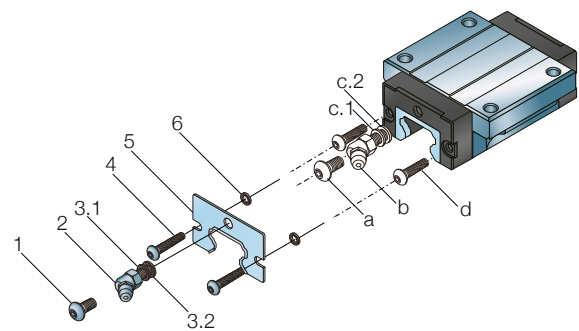

4.3.2 Mounting an additional front seal (S7)

1. Remove the grease nipple (b) and washers (c.1 and c.2), or the set screw (a) (↳ fig. 27)
2. Remove the mounting screws (d)
3. Attach the additional front seal (5) onto the end plate, and position it accurately against the latter.
4. Install the mounting screws (4)
5. Install the grease nipple (2) and washers (3.1 and 3.2) if necessary.
6. If a grease nipple is not required, install a set screw (1) instead.

Fig. 27

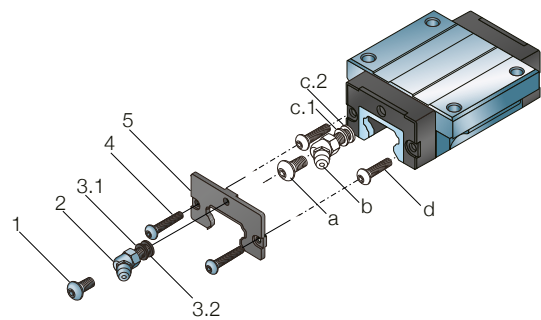

4.3.3 Mounting the seal kit (S3)

Fig. 28

1. Remove the grease nipple (b) and washers (c.1 and c.2), or the set screw (a) (→ fig. 28)
2. Remove the mounting screws (d)
3. Attach the additional front seal (7) onto the end plate, and position it accurately against the latter.
4. Put the washers for mounting screws (6) on both sides. The washers are put between the metal scraper (5) and the additional front seal (7)
5. Attach the metal scraper plate (5) on the additional front seal (7), and align them with each other.
6. Install the mounting screws (4)
7. Install the grease nipple (2) and washers (3.1 and 3.2) if necessary.
8. If a grease nipple is not required, install a set screw (1) instead.

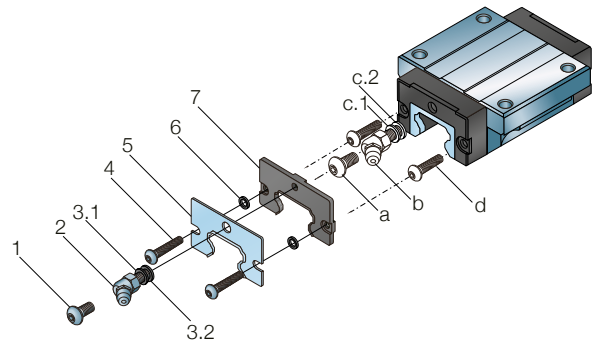

4.3.4 Mounting the low friction shield (S0)

Fig. 29

1. Remove the grease nipple (b) and washer (c.1 and c.2), or the set screw (a) (→ fig. 29)
2. Remove the mounting screws (d)
3. Remove the front seal (e) and replace it with the low friction shield (1).
NOTE: Make sure that the foam remains in its correct place.
4. Re-install the mounting screws (d)
5. Install back the grease nipple (b) and washers (c.1 and c.2) if necessary.
6. If a grease nipple is not required, install a set screw (a) instead.

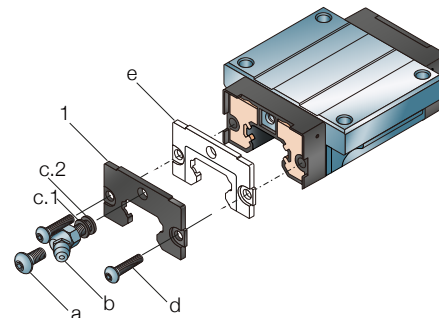

4.3.5 Mounting the LLT Lube element (S6)

Mounting

1. Remove grease nipple (b) and washers (c1, c2) or the set screw (a) (↳ fig. 30)
2. Remove the mounting screws (d) Remove the front seal (e) and replace it with the low-friction shield (h)
3. Position the lube element (g) in front of the low-friction shield (h)
4. Add the front seal (e) to the lube element (g)
5. Install the new mounting screws (f) and tighten them with the given torque
6. Move the carriage with the mounted lube element on the rail and check the sealing function (if bad, adjust the seal)
7. Install the grease nipple (b) and washers (c1, c2) if necessary
8. If the grease nipple (b) is not required, install the set screw (a) instead

Fig. 30

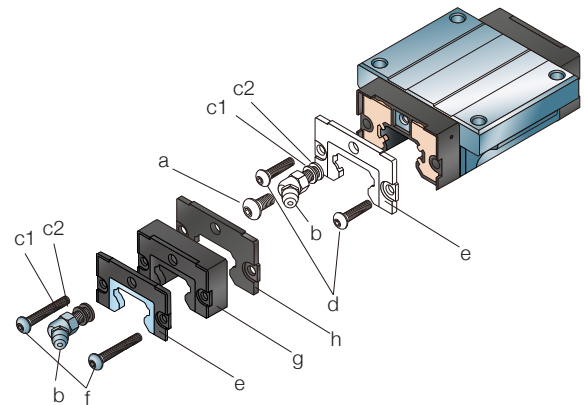

Replacement

1. Remove grease nipple (b) and washers (c1, c2) or the set screw (↳ fig. 31)
2. Remove the mounting screws (f)
3. Pull the front seal (e) away from the old lube element
4. Pull the old lube element away from the carriage and remove from the rail
5. Position the new lube element (g) onto the rail as shown
6. Push the front seal (e) together with the new lube element to the carriage
7. Install the mounting screws (f) and tighten them with the given torque
8. Move the carriage with the mounted lube element on the rail and check the sealing function (if bad, adjust the seal)
9. Install the grease nipple (b) and washers (c1, c2) if necessary
10. Re-grease the carriage as described on page 93
11. If grease nipple (b) is not required, install a set screw after re-greasing instead

Fig. 31

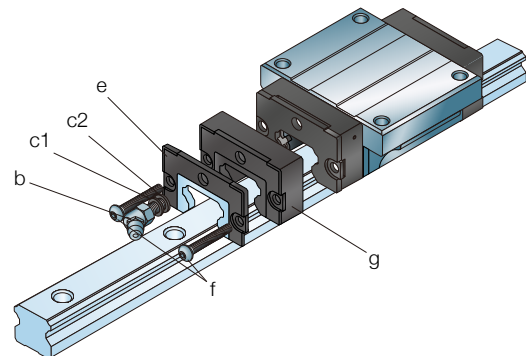

4.3.6 Mounting an adapter plate (PL)

1. Remove the grease nipple (b) and washers (c.1 and c.2), or the set screw (a) (↳ fig. 32)
2. Remove the mounting screws (d)
3. Attach the adapter plate with sealing ring (3) onto the end plate, and position it accurately against the latter.
4. Put the washers (4) for mounting screws on both sides.
5. Install the mounting screws (1)
6. Install the original grease nipple (b) and washers (c.1 and c.2) on the lateral side of the adapter plate.
7. Install the set screw (2) on the other side of the adapter plate.

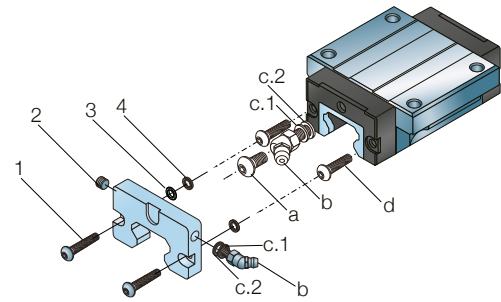

Fig. 32

4.3.7 Mounting the grease nipple and lubrication connector (VN UA)

1. Remove the grease nipple (b) and washers (c.1 and c.2), or the set screw (a) (↳ fig. 33)
2. Install the lubrication connector (1) onto the lube port.

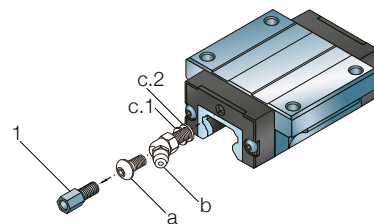

Fig. 33

4.3.8 Mounting the bellows

Bellows are available for all sizes of profile rail guides. The bellows are used to provide additional protection against dirt, dust and splashed liquids over the entire rail length. Grease nipples are applied laterally and are accessible without disconnecting the bellows.

Pre-assemble the adapter set

See 4.3.6 Mounting an adapter plate.

Assemble the bellows on the system

Move the carriage to the end of the rail. Then put the fixation plate (14) behind the last frame and tighten it together with the bellow and the screws (13) into the adapter plate on the carriage (→ fig. 35).

Take the end plate (8), the fixation plate (9), the screws (11) and the bellow and put the fixation plate behind the first frame of the bellow and screw all the parts together (→ fig. 36).

At least fix the end plate (8) with the screw (12) to the threaded hole at the end of the rail (15).

NOTE: To have a look onto the rail, remove the screw (12) at the end of the rail (→ fig. 36) and lift the bellow carefully from the rail or move to the end of the rail.

Fig. 34

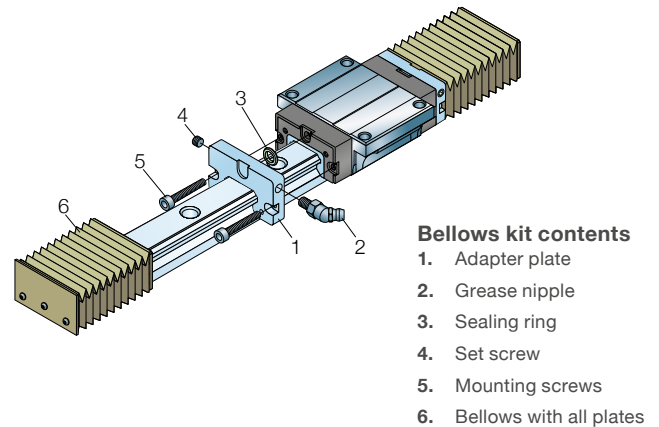

Fig. 35

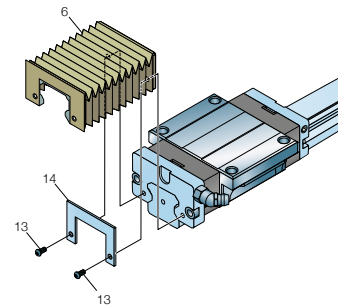
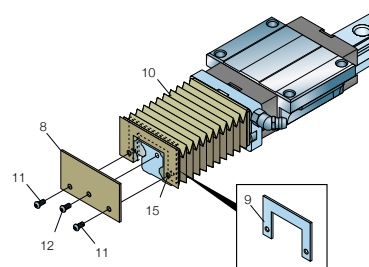

Fig. 36



4.4 Maintenance and repairs

4.4.1 Preventative maintenance

To avoid dirt from adhering to and embedding into the rails, the rails should be cleaned regularly with a cleaning stroke. Ewellix recommends a cleaning stroke over the entire length of the rails twice a day or at least after eight hours of operation.

Perform a cleaning stroke each time when switching the machine on or off.

4.4.2 Lubrication

The appropriate type and amount of lubricant is required for rolling bearings to function reliably. To reduce wear, the lubricant prevents direct metal-to-metal contact between the rolling elements and the raceways. In addition, the lubricant protects the rail and carriage from corrosion.

The guidance system can only realize its optimum operating temperature when a minimum amount of lubricant to reliably lubricate the profile rail guide is applied.

Grease lubrication

Under normal operating conditions, LLT profile rail guides should be lubricated with grease. The advantage of grease is that it is more easily retained in the bearing, which is par-

ticularly important when the axis of travel is inclined or vertical. Moreover, it contributes to sealing the bearing against the ingress of liquid contaminants or humidity.

Base oil viscosity

The viscosity of a lubricating oil is key to the formation of the hydrodynamic film that separates the rolling elements from the raceways.

In general, the viscosity of lubricating oils is based on the flow rate at 40 °C. These values also apply to the mineral base oils contained in lubricating greases.

The base oils of commercially available rolling bearing greases have viscosity values between 15 and 500 mm²/s (at 40 °C). Greases with higher base oil viscosities often release too slowly to sufficiently lubricate bearings.

Consistency class

Lubricating greases are divided into various consistency classes according to a scale by the National Institute of Grease Lubrication (NLGI). These are also reflected in DIN 51 818 and DIN 51 825.

Table 7

A selection of SKF rolling bearing greases

Properties	Lubricant (designation)			
	LGEP 2	LGMT 2	LGLT 2	LGFP 2
Thickener	Li	Li	Li	Al complex soap
Base oil	Mineral oil	Mineral oil	Di-ester oil	Medical white oil
Operating temperature, °C (steady state)	-20 up to +110	-30 up to +120	-55 up to +110	-20 up to +110
Kinematic viscosity of base oil mm ² /s	200	110	15	130
Consistency class (acc. to NLGI)	2	2	2	2
Temperature range / Application range	Grease with extreme pressure (EP) additives > best grease for standard environment	normal temperature	low temperature	food compatible

Greases with a metallic soap thickener with a consistency of 2 or 3 on the NLGI scale are particularly suitable for use with Ewellix profile rail guides. The grease consistency should not vary too much with changing operating temperatures or stress levels. Greases that soften at higher temperatures can leak from the bearing position, while greases that get stiffer at lower temperatures can impede the operation of the linear guidance system.

Specific requirements are placed on the lubricating grease's purity, composition and compatibility if the grease is to be used in special applications, for instance in the food sector, medical engineering, etc. In such cases, criteria should be further specified for the lubricant in addition to viscosity and consistency class.

Temperature range

The temperature range over which a lubricant can be used depends largely on the type of base oil and thickener as well as the additives.

The low temperature limit, the lowest temperature at which the grease enables the bearing to be started up without difficulty, is largely determined by the type of base oil and its viscosity. The high temperature limit is determined by the type of thickener and its dropping point. The dropping point is the temperature at which a grease changes its consistency and becomes a fluid.

NOTE: Grease will age with increasing rapidity at higher operating temperatures. The resulting by-products have a detrimental effect on the grease's lubrication properties and conditions in the rolling contact zone.

Lubricating greases with synthetic base oils can be used both at higher and lower temperatures than lubricants with a mineral oil base.

Corrosion inhibiting additives in lubricants

Lubricants typically contain additives to inhibit corrosion. In addition, the type of thickener is crucially important in this regard.

Lithium-base and calcium-soap greases provide excellent corrosion protection properties. They are also resistant to water wash-out.

In applications where corrosion protection is a key operational parameter, Ewellix recommends coated LLT profile rail guides and a grease with a good rust preservative (↳ [page 22](#)).

SKF bearing greases

The assortment of SKF greases has been developed based on the latest information about rolling bearing lubrication and has undergone extensive testing both in the laboratory and under field conditions.

Table 7 page 91 lists those SKF greases that are particularly well-suited for LLT profile rail guides. Additional information and special lubricant recommendations are available from Ewellix upon request.

NOTE: Tests have shown that SKF LGEP 2 grease will perform satisfactorily in the majority of applications.

Factory pre-lubrication

LLT carriages are normally supplied pre-lubricated with SKF LGEP 2 grease. The technical data for this grease can be found in **page 91, table 7**. A preservative is applied to the LLT rails and carriages to protect them during transport, storage and mounting. When using the recommended lubricants, it is not necessary to remove this preservative.

NOTE: The nickel-plated carriages are delivered unlubricated and must be greased by the customer prior to use and re-lubricated at regular intervals.

NOTE: In addition, there are unlubricated carriages available on request that are completely protected with a preservative. These carriages must be greased by the customer.

Initial lubrication

Initial lubrication is not required since Ewellix profile rail guides are delivered pre-greased and ready to install unless specified otherwise. In cases where a different type of grease is required, the carriages should be thoroughly cleaned and regreased prior to mounting. Alternatively, the carriages can be ordered without grease. Please refer to **table 8** for appropriate grease quantity.

This initial grease fill should be applied three times according to the steps below:

1. Grease each carriage according to the quantities listed (↳ **table 8**).
2. Move the carriage three times backwards and forwards with stroke longer than carriage length.
3. Repeat steps **1** and **2**, twice more.
4. Check if a lubricating film is visible on the rail.

Relubrication

The lubrication intervals for profile rail guides depend primarily on the average running speed, operating temperature and grease quality.

The intervals recommended for fixed operating conditions are listed in **table 9**. For appropriate grease quantity refer to **table 8**. Where contamination, use of coolants, vibration, shock loads etc. form part of the environmental conditions, it is advisable to reduce relubrication intervals accordingly.

NOTE: For P_m determination, please use **formula 8** to calculate constant mean load described on **page 26**. Also, consider recommended lubrication intervals in **table 9**.

Table 8

Size	Grease quantity		
	Carriage type A, U, R	LA, LU, LR	SA, SU
–	cm ³		
15	0,4	–	0,3
20	0,7	0,9	0,6
25	1,4	1,8	1,1
30	2,2	2,9	1,8
35	2,2	2,9	1,8
45	4,7	6,1	–

Table 9

Size	Lubrication intervals ¹⁾	
	Under normal operating conditions, $v \leq 1$ m/s Travel under load	
–	$P_m \leq 0,15$ C km	$P_m \leq 0,3$ C
15	5 000	1 200
20	5 000	1 200
25	10 000	2 400
30	10 000	2 400
35	10 000	2 400
45	10 000	2 400

¹⁾ NLGI 00 grease reduces the relubrication intervals to 75 % of the stated values

Short stroke applications

If the stroke is less than twice the carriage length, both lube ports must be used, each filled equally with the grease quantity stated for initial lubrication or relubrication.

Example

- Short stroke application
- Carriage type A
- Size 25

Apply 3 × 1,4 cm³ into the left and 3 × 1,4 cm³ into the right grease nipple.

Important: To avoid serious damage to the rail guides, it is important to consider the miscibility of greases when changing from one lubricant to another.

Moreover, you must also consider the possibility of reduced relubrication intervals when performing at a short stroke operation and reduced load carrying capacity as well as the possibility of chemical interaction with synthetic materials, lubricants and preservatives.

Please refer to the grease manufacturer’s instructions. In case of incompatibility between lubricants employed, the carriages should be thoroughly cleaned before re-greasing.

Central lubrication systems

If the application features a central lubrication system using greases with a consistency of 2 or higher on the NLGI scale, contact Ewellix.

Initial lubrication with adapter plate or bellow

During the first relubrication of a carriage with adapter plate, it is important to increase the amount of lubricant according to **table 10**.

4.4.3 Replacement

If the LLT profile rail guide system has reached the end of its service life and has to be replaced, Ewellix recommends replacing the whole system.

Please locate the name of the ordering key written on the carriage and measure the rail length and the E-dimension (the distance from the rail end to the first hole) for re-ordering.

Table 10

Size	Additional grease quantity
–	cm ³
15	0,2
20	0,4
25	0,4
30	0,5
35	0,6
45	0,7

4.5 Typical application areas

Typical application areas

Applications	Precision classes			Preload classes			Special requirements on	
	P5	P3	P1	T0	T1	T2	Speed	Sealing
Handling								
Linear robotics	•	•		•	•		•	
Linear tables	•	•	•	•	•	•	•	
Modules and axis	•	•		•	•			
Pneumatic automation	•	•		•	•		•	
Plastic injection moulding								
Clamping / injecting	•	•		•	•		•	
Machine hood	•			•				
Woodworking								
Portal and gantry	•	•	•	•	•	•	•	•
Machine hood	•			•				
Printing								
Cutting and transport systems	•			•	•			•
Packaging								
Labelling	•	•		•				
Stacking/palletizing	•	•		•	•		•	
Medical								
X-ray	•	•		•	•			
Patient tables	•	•		•	•			•
Laboratory automation	•	•		•	•			•
Machine tool								
Cutting	•	•	•	•	•	•	•	•
Sawing	•	•		•	•	•	•	

4.6 Customized solution

Basic customization

The basic design option can be implemented quickly and easily:

- Special E value (e.g., small than Emin...etc.)
- Special laser mark for rails/carriages
- Pitch of rail's mounting holes
- Bulk packages
- Smaller tolerance for E value
- Non initial lubrication carriage

Advanced customization

The design options are more complex and require a dedicated project with the customer:

- Dimensions of rail's mounting holes
- Special carriage's mounting holes
- Dowel pin hole for the rails/carriages
- Shorter length of carriages
- Special preload class

Fig. 37

Special carriage's mounting holes

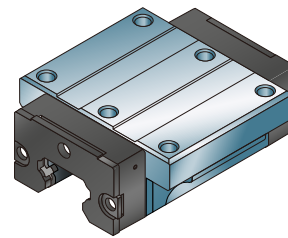

Fig. 38

Shorter length of carriages

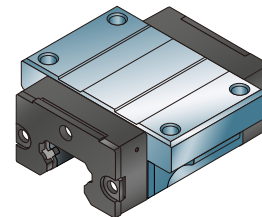

Fig. 39

Special Rail mounting holes

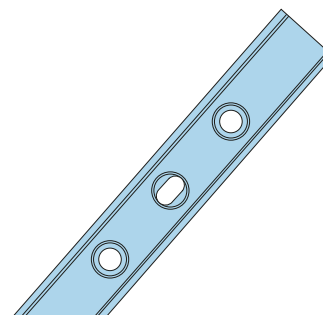
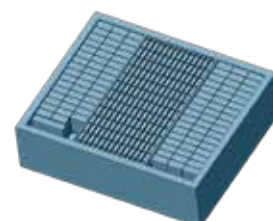

Fig. 40

Bulk packages



4.7 FAQ

What is a profile rail guide?

Profile rail guide systems, consisting of rails and carriages, are high precision linear guidings and can be found in almost all kinds of machines. Main characteristics are high load and moment carrying capacity, positioning accuracy and virtually unlimited stroke due to recirculating rolling elements. Available in a wide range of sizes, carriage types and accessories as well as in various preload and accuracy classes, LLT profile rail guides facilitate the adaptation to individual application demands.

What is the maximum permissible operating temperature?

LLT rail guides can operate continuously at temperatures ranging from -20 to 80 °C. They can operate at temperatures up to 100 °C for brief periods only.

What is a Precision Class?

Precision classes define the maximum permissible tolerance range of a rail system in terms of height, width and parallelism. Ewellix manufactures its LLT profile rail guides in three accuracy classes. This choice determines the positioning accuracy of the system within the application (→ page 17).

Which main constructional differences can be found on the market for Profile rail guides?

The market offer is separated into PRG with either X – or O-arrangement of the recirculating ball rows. The technical characteristics of these two arrangements are the same except for their behaviour when subjected to a torsional moment. Generally they show no difference in behaviour when it comes to compressive loads, lift-off loads and side loads

or under longitudinal moments. The profile rail guides from Ewellix feature an X-arrangement (→ fig. 41). The advantage of this arrangement is that deviations in parallelism and height, which usually appear in multi-axis systems, can be more effectively compensated for (→ fig. 42). Due to the design-related smaller lever arm, the X-arrangement provides better self-aligning capability. In combination with a two-point contact of the rolling elements, running friction is kept to a minimum. This results in smooth and stick-slip-free operation of the guidance system.

Fig. 41

Schematic illustration of the different ball-arrangements

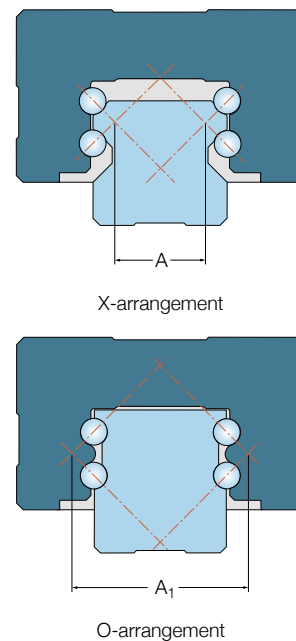
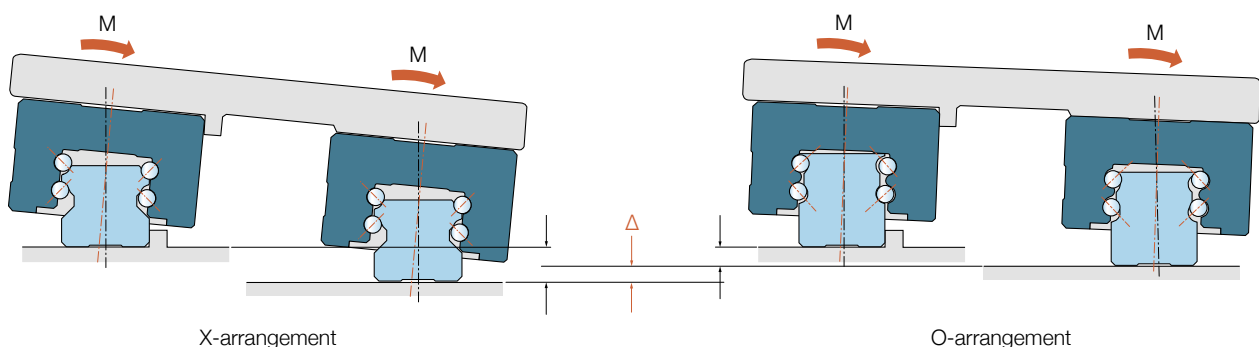

Fig. 42

Self-aligning capability in comparison



What is preload? Which influence has preload within a Profile rail guide system?

Preload is an initial load or "negative clearance" given to a profile rail guide. This results in the rolling element and race-way surfaces being under constant elastic compressive forces at their contact points. To adjust a profile rail guide to the specific demands of a given application, it is advisable to choose an appropriate preload. This will positively affect the operating behaviour of the entire linear guidance system. Preload increases the stiffness of linear guides and thus reduces the deviation under load. The preload should not amount to more than 1/3 of the bearing load F to avoid negative effects on the guide's service life. Preload can not be adjusted by the customer!

Which preload classes does Ewellix offer?

T0 – Zero preload (zero to light preload)

For extremely smooth-running rail guide systems with low friction and low external influences. This preload class is only available in P5 and P3 accuracy classes.

T1 – Light preload (2 % of dynamic preload C)

For precise rail guide systems with low external load and high requirements for overall stiffness.

T2 – Medium preload (8 % of dynamic preload C)

For precise rail guide systems with high external load and high requirements for overall stiffness, also recommended for single-rail systems. Above-average moment loads are absorbed without any significant elastic deformation. At only medium moment loads the overall stiffness is further improved.

What materials are used for the profile rail guides?

Material specifications.

The different parts of a profile rail guide system are shown in **fig. 44**.

1. Steel, inductive hardened
2. Steel, case hardened
3. Bearing steel
4. Steel, zinc coated
5. POM, reinforced
6. EPU foam
7. Elastomer
8. Steel
9. Steel, nickel coated

Fig. 43

Generation of preload

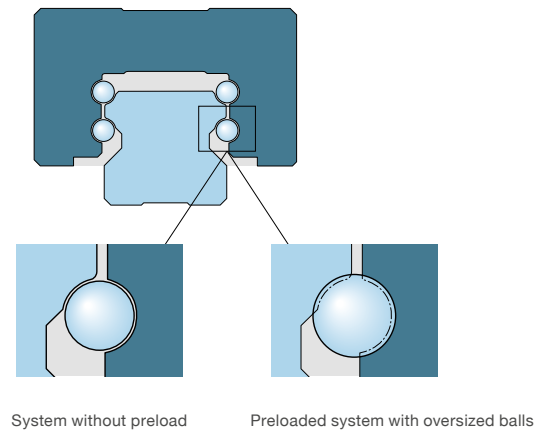
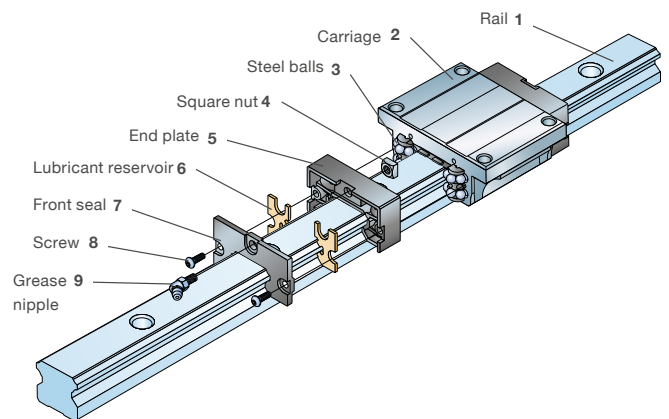

Fig. 44



What are the friction values for a LLT profile rail guide system?

The friction coefficient for lubricated LLT profile rail guides is typically between $\mu = 0,003$ and $0,005$. This is valid for carriages without seals. The use of seals increases the friction. An overview of the impact on the friction force is available at **page 20 and 21**.

What is the maximum rail length without joints?

The maximum length of a single rail L_{max} is approximately 4 000 mm. The exact dimensions are shown at **page 57**. For virtually unlimited stroke joint rails are available. The end faces of joint rails are ground and marked accordingly.

Can profile rail guides be equipped with a clamping element?

Yes - on request. Profile rail guides can be equipped with pneumatic, hydraulic, electric and manual operating brakes.

How can the profile rail guide be protected from contamination?

For protection several accessories are available (→ **page 62**).

Accessories:

S1 = Scraper plate

S3 = Seal kit, additional front seal with scraper plate

S7 = Additional front seal

B = Bellows

Can the rails be mounted from below?

Yes, we offer LLTHR ... D4 rails with blind holes (→ **page 58**).

Lubricant specification

LLT carriages are factory pre-lubricated with SKF LGEP 2 grease of consistency class NLGI 2, which is in accordance with DIN 51 825.

We recommend LAGG 18AE SKF Mobile grease pump for frequent use, or the Grease Gun LAGH 400 with the UMETA nozzle pipe for infrequent use.

Is a centralized lubrication possible?

Both ends of the carriage have metal threaded lubrication ports to accommodate an automatic relubrication system. The Lubrication connectors which are for the centralized lubrication system are referred to **page 70**.

Is it possible to lubricate the carriages from the side / lateral?

Lubrication from the side is only possible by using an additional adapter plate (component of the bellows kit see **page 72**).

What has to be considered concerning the lifetime of the lubricant?

The temperature range of -20°C to 80°C should not be exceeded for longer periods.

If the stroke is less than twice the carriage length, both lube ports must be used, each filled equally with the grease quantity stated for initial lubrication or re-lubrication.

For lubrication information please refer to **chapter 4.4.2**.

Is it possible to pull the carriage off the rail?

It is possible to remove the carriage from the rail. The de-mounting of a profile rail guide must be done carefully and requires the original mounting sleeve.

In case of remounting systems make sure that each carriage is mounted on the rail from which it was removed, in the same mounting direction.

Does the customer need to mount the carriage to the rail?

Yes, if a standard system is ordered. Optionally LLT systems can be ordered as an assembled system using "M" in the designation code.

What should be considered to make the right choice regarding a profile rail guide?

The specification sheet at **page 107** guides you through the dimensioning of a profile rail guide. It asks for all relevant information which includes loads, velocities, orientation, intended use, environment, etc. and results in the appropriate system.

Is it possible to replace only the carriage or the rail of a system that was in use?

Yes, due to our profile rail guide concept, the exchange is possible for the most common technical specifications. All carriages and rails of the same size and precision class P5 or P3 can be combined with each other while maintaining the initial precision class.

NOTE:

1. Precision class P1 is only as profile rail guide system available. Rails and carriages with precision class P1 are not interchangeable.
2. Preload/Precision class T2 P3 is only as profile rail guide system available. Rails and carriages with Preload/Precision class T2 P3 are not interchangeable.
3. It is recommended to replace the entire profile rail guide system when confirmation of a particular condition is required(e.g. end of life-cycle) even if only one part of it is damaged.

Why can dynamic load ratings deviate when comparing competitor products, especially of Asian companies, although the relevant dimensions are comparable?

The basic dynamic load rating and moment load rating of LLT is based on 100 km (according to ISO 14728 Part 1). However, the values of some other manufactures are frequently based on only 50 km. When comparing values, multiply the C values for LLT profile rail guides by 1.26.

What has to be considered in case of short-stroke application (stroke < 2x carriage length)?

If the given application stroke is less than twice the carriage length, both lube ports must be used, each filled equally with the grease quantity stated for initial lubrication or re-lubrication.

In case of oscillating motion or short-stroke it is recommendable to move the carriages frequently for a full stroke or at least more than twice the carriage length.

If the application desires short strokes, shocks loads or high speeds it is advisable to reduce the relubrication intervals accordingly. And EP/AW additive and NLGI 1 grease are recommended in this kind of application.

Is it possible to replace balls in case of accidental ball loss?

That is not recommended. The preload class depends on the ball diameter which varies minimally from carriage to carriage to meet the technical specifications. As long as the carriage is undamaged, balls will not fall out.

What could be causes for noise during the operation of a profile rail guide?

If a profile rail guide causes noise, different causes or a combination of them should be considered:

- Velocity exceeds the permitted maximum values
- Inaccurate mounting
- Interface construction not stiff enough
- Surface of interface construction not according to recommendations at **page 78 and 79**
- Wrong or insufficient grease

What is the stick-slip phenomenon?

Stick-slip (or "slip-stick") refers to the phenomenon of a spontaneous jerking motion that can occur while two objects are sliding over each other. This can lead to an undesirable noise. Stick-slip is caused by the surfaces alternating between sticking to each other and sliding over each other (mixed friction), with a corresponding change in the force of friction. Typically, the static friction coefficient between two surfaces is larger than the kinetic friction coefficient. If an applied force is large enough to overcome the static friction, then the reduction of the friction to the kinetic friction can cause a sudden jump in the velocity of the movement. Stick-slip phenomenon is comparative untypical for profile rail guides but can rarely occur when the actuator is lean / small designed or the system is moving slow.

4.8 Ordering key

4.8.1 Ordering key system

LLTH	S	25	A	2	T2	1000	P5	HD	S0	A	B0	D4	E0	M	S1	C	M
------	---	----	---	---	----	------	----	----	----	---	----	----	----	---	----	---	---

Size _____
 15, 20, 25, 30, 35, 45

Carriage type¹⁾ _____
 SA Flanged carriage, short length, standard height
 A Flanged carriage, standard length, standard height
 LA Flanged carriage, extended length, standard height
 SU Slim-line carriage, short length, standard height
 U Slim-line carriage, standard length, standard height
 LU Slim-line carriage, extended length, standard height
 R Slim-line carriage, standard length, extended height
 LR Slim-line carriage, extended length, extended height

Number of carriages per rail _____
 1, 2, 4, 6, ...

Preload class _____
 T0 Zero preload
 T1 Light preload, 2 % C
 T2 Medium preload, 8 % C

Rail length _____
 80 mm up to maximum rail length (1 mm steps)

Precision class _____
 P5 Standard
 P3 Medium
 P1 High

**Coating^{2) 3) 4) 5) 11)} (no code for standard: non coated rails and carriages) _____
 HD- Thin dense chrome rail with non coated carriage, available in Europe
 HA- Thin dense chrome rail with non coated carriage, available in USA/CAN
 HDN Thin dense chrome rail with nickel plated carriage, available in Europe
 HAN Thin dense chrome rail with nickel plated carriage, available in USA/CAN**

**Sealing^{9) 10)} (no code for standard sealing) _____
 S0 Low friction shield**

**Jointed rail track⁶⁾ (if not selected – no code) _____
 A Yes**

**Prepared for bellows (if not selected – no code) _____
 B0 Rails prepared for bellows (for ordering the bellow see ordering key bellows), available in Europe**

Rail _____
 D Rail, if customized according to drawing number
 D4 Rail with blind holes
 D6⁷⁾ Rail with metal plugs

Distance between end face and the center of the first mounting hole of the rail _____
 E0 If no “E” specified, the holes at both rail ends will be positioned equidistantly from either end of the rail (shortest possible “E” dimension)
 Exx “E” dimension to be specified, for calculation and minimum “E” dimension (↳ page 57)

LLTH	S	25	A	2	T2	1000	P5	HD	S0	A	B0	D4	E0	M	S1	C	M
------	---	----	---	---	----	------	----	----	----	---	----	----	----	---	----	---	---

Carriage mounted on rail (if not selected – no code) _____

M Yes

Additional seals, when part of a system (other and separate available parts see ordering key accessories) _____

- S1 Scraper plate
- S3 Seal kit, additional front seal with scraper plate
- S7 Additional front seal
- S6 Lube element
- 61 Lube element + Scraper plate
- 63 Lube element + Seal kit, additional front seal with scraper plate
- 67 Lube element + Additional front seal

Quantity of additional seals _____

- C (2) seals per carriage
- S (2) seals per system, outer surface of carriages to have seal mounted

Additional seals mounted on carriage ⁸⁾ (if not selected – no code) _____

M Yes

- ¹⁾ Not all combinations of preload / precision class available for each carriage type. Please refer to **pages 38 to 53**.
- ²⁾ Available coated carriage types refer to **page 22 (table 7)**.
- ³⁾ Only available in preload classes T0 and T1 and precision class P5.
- ⁴⁾ Please note: a system with coated rail can have a slightly higher preload and friction. This will be partly eliminated after a short running time. Be aware, that the end of the rail is not normally coated.
- ⁵⁾ For size 15 and 20, only carriages with low friction S0 shield shall be used. If seal function is needed, a combination with additional front seal S7 is recommended.
- ⁶⁾ Jointed rail code should be selected if the ordered rail length exceeds the maximum standard rail length (defined in dimension tables, **pages 38 to 53**).
- ⁷⁾ Available for size 25–45. Mounting tool needs to be ordered separately (→ **ordering key accessories**).
- ⁸⁾ Additional seals can only be mounted on carriage if full system is ordered (Carriage mounted on rail = Yes).
- ⁹⁾ Not for size 35 and 45.
- ¹⁰⁾ LLTH 15 and 20 HN are always equipped with S0 as STANDARD.
- ¹¹⁾ Without lubricant, corrosion protected only.

4.8.2 Ordering key carriages

LLTH	C	25	A	T2	P5	HN	S0
------	---	----	---	----	----	----	----

Size _____

15, 20, 25, 30, 35, 45

Carriage type ¹⁾ _____

- SA Flanged carriage, short length, standard height
- A Flanged carriage, standard length, standard height
- LA Flanged carriage, extended length, standard height
- SU Slim-line carriage, short length, standard height
- U Slim-line carriage, standard length, standard height
- LU Slim-line carriage, extended length, standard height
- R Slim-line carriage, standard length, extended height
- LR Slim-line carriage, extended length, extended height

Preload class _____

- T0 Zero preload
- T1 Light preload, 2 % C
- T2 Medium preload, 8 % C

Precision class _____

- P5 Standard
- P3 Medium
- P1 High

Coating ^{2) 3) 4) 7)} (no code for standard: non coated carriage) _____

HN Nickel plated carriage

Sealing ^{5) 6)} (no code for standard sealing) _____

S0 Low friction shield

- ¹⁾ Not all combinations of preload / precision class available for each carriage type. Please refer to **pages 38 to 53**.
- ²⁾ Only available for preload class T0 and T1, precision class P5. For an overview of the available carriages with coating, please refer to **page 22, table 7**.
- ³⁾ Please note: a system with coated rails can have a slightly higher preload and friction. This will be partly eliminated after a short running time.
- ⁴⁾ For size 15 and 20, only carriages with low friction S0 shield shall be used. If seal function is needed, a combination with additional front seal S7 is recommended.
- ⁵⁾ Not for size 35 and 45.
- ⁶⁾ LLTH 15 and 20 HN are always equipped with S0 as STANDARD.
- ⁷⁾ Without lubricant, corrosion protected only.



4.8.3 Ordering key rails

	LLTH	R	25	1000	P5	HD	A	B0	D4	E0
Size _____ 15, 20, 25, 30, 35, 45										
Rail length _____ 80 mm up to maximum rail length (1 mm steps)										
Precision class _____ P5 Standard P3 Medium P1 High										
Coating ¹⁾²⁾ (no code for standard: non coated rail) _____ HD Thin dense chrome rail, available in Europe HA Thin dense chrome rail, available in USA/CAN										
Jointed rail track ³⁾ _____ A Yes										
Prepared for Bellows _____ B0 Rails prepared for bellows. To order, see “ordering key bellows.”, available in Europe										
Rail ⁴⁾ _____ D Rail, if customized according to drawing number D4 Rail with blind holes D6 ⁵⁾ Rail with metal plugs										
Distance between end face and the center of the first mounting hole of the rail _____ E0 If no “E” specified, the holes at both rail ends will be positioned equidistantly from either end of the rail (shortest possible “E” dimension) Exx “E” dimension to be specified, for calculation and minimum “E” dimension, (↳ page 57)										

¹⁾ Only available in precision class P5.

²⁾ Please note: a system with coated rail can have a slightly higher preload and friction. This will be partly eliminated after a short running time. Be aware that, as standard, the end of the rail is not coated.

³⁾ Jointed rail code should be selected if the ordered rail length exceeds the maximum standard rail length (defined in dimension tables, [pages 38 to 53](#)).

⁴⁾ Plastic and metal plugs available as spare parts. Please contact Ewellix for further information.

⁵⁾ Available for sizes 25–45. Mounting tool needs to be ordered separately (see ↳ [ordering key accessories](#)).

4.8.4 Ordering key accessories (delivered separately)

	LLTH	Z	25	S1
Size _____ 15, 20, 25, 30, 35, 45				
Accessories (will be delivered as single units) _____ S0 ¹⁾ Low friction shield S1 Scraper plate S3 Seal kit, additional front seal with scraper plate S7 Additional front seal PL Adapter plate, used for side lubrication VN UA ²⁾ Lubrication connector D6 ³⁾ Mounting tool for metal plugs S6 Lube element 61 Lube element + Scraper plate 63 Lube element + Seal kit, additional front seal with scraper plate 67 Lube element + Additional front seal				

¹⁾ Available for sizes 15–30 to replace standard front seal.

²⁾ Fits for all types of carriages (↳ [page 37](#)), but not in combination with additional seals (S1/S3/S7).

³⁾ Available for sizes 25–45.

4.8.5 Ordering key bellows

LLTH	B	25	B	(xxx/xxx/xxx)	LAS
------	---	----	---	---------------	-----

Size _____
15, 20, 25, 30, 35, 45

Bellows ¹⁾ _____
 B Combination of bellows to cover the complete system
 B2 Kit, type 2 (carriage to the end of the rail)
 B4 Kit, type 4 (between two carriages)
 B9 Bellow as spare part (without any fastening system)

Bellows: definition of number of folds (max 150 folds per single bellow) _____
 xxx Number of folds
 / Splitting of sections
 - No bellows in this section

Bellows material _____
 STD Standard material "PUR", (temperature resistance +90 °C)
 LAS ²⁾ Special material suitable for laser applications – self fading, (temperature resistance +160 °C)
 WEL ³⁾ Special material suitable for welding applications, (temperature resistance +260 °C)

The bellows is only available in Europe.

¹⁾ Will be delivered unmounted

²⁾ Available for sizes 15-30

³⁾ Available for sizes 35-45

5

**Customer
specification sheet**



Specification sheet – Profile rail guide LLT

Please complete the form with all available information and send it to your Ewellix representative or authorized distributor for product selection.

Ewellix contact	Date
-----------------	------

General information

Customer

Company		
Address 1		
Address 2		
Post code / Zip	City	State
Country		

Contact

Contact name	
Job title	
Department	
Phone (including country code)	Mobile (including country code)
Mail	

Project title

Reason for request

<input type="radio"/> Replacement <small>Current product / brand</small>	<input type="radio"/> New design <small>Description</small>	<input type="radio"/> Other <small>Description</small>
--	---	--

Application / Industry

<input type="radio"/> Factory automation <input type="radio"/> Food and beverage <input type="radio"/> Machine tools <small>Description</small>	<input type="radio"/> Medical <input type="radio"/> Semiconductor <input type="radio"/> Other <small>Description</small>
---	--

Export control and Ewellix policy (mandatory to mark)

<input type="radio"/> The application is not subsidiary or part of industry of national defence and/or nuclear (also not with details of the function). The application is civil.
--

Commercial information

General

<input type="radio"/> One shot business <input type="radio"/> Yearly repeating business	Quantity, pcs	Batch size, pcs	Start of supply, YYYY MM DD	Target price / each	Currency
--	---------------	-----------------	-----------------------------	---------------------	----------

Application description

Specification sheet – Profile rail guide LLT

Stroke	Rail length	Center distance between	or Short part dimensions	Guiding system
<input type="text" value="mm"/>	<input type="text" value="mm"/>	carriages, c <input type="text" value="mm"/> rails, d <input type="text" value="mm"/>	Length <input type="text" value="mm"/> Width <input type="text" value="mm"/>	Maximum height <input type="text" value="mm"/>
				<input type="radio"/> No constraints

Required service life distance or time (fill in all fields)				Required static safety (in accordance to your business and application)
Distance <input type="text" value="km"/>	Total time <input type="text" value="h"/>	Period of one cycle <input type="text" value="s"/>	Stroke of one cycle <input type="text" value="mm"/>	<input style="width:100%; height:20px;" type="text"/>

Maximum speed ¹⁾	Maximum acceleration ¹⁾	Rigidity of guiding system	Running accuracy of guiding system
<input type="text" value="m/s"/>	<input type="text" value="m/s<sup>2</sup>"/>	<input type="text" value="N/μm"/>	Parallelism in height <input type="text" value="μm"/>
<input type="radio"/> No specific requirements		Parallelism in sideward direction <input type="text" value="μm"/>	

¹⁾ Here the maximum values. Enter load phase specific values in table "External loads and load phases"

Environment		
Presence of dust, dirt or fluids <input type="radio"/> Clean environment, e.g. laboratory <input type="radio"/> Standard industrial environment <input type="radio"/> Dirty environment, e.g. milling machine	Requirements on friction <input type="radio"/> Lowest possible friction <input type="radio"/> Standard friction <input type="radio"/> No requirement	Preferred sealing version <input type="radio"/> Low friction shield (S0) <input type="radio"/> Standard sealing <input type="radio"/> Scraper plate (S1) <input type="radio"/> Additional front seal (S7) <input type="radio"/> Seal kit (S3) <input type="radio"/> Bellow
<input type="radio"/> Humid or corrosive environment If yes, please describe:	Preferred material <input type="radio"/> No preference (standard) <input type="radio"/> Coated steel	

Temperature [°C]	<input type="radio"/> Shockloads or vibrations			
<table border="1" style="width:100%; border-collapse: collapse;"> <tr> <td style="width:33%;">Minimum <input type="text"/></td> <td style="width:33%;">Operating <input type="text"/></td> <td style="width:33%;">Maximum <input type="text"/></td> </tr> </table>	Minimum <input type="text"/>	Operating <input type="text"/>	Maximum <input type="text"/>	If yes, please describe:
Minimum <input type="text"/>	Operating <input type="text"/>	Maximum <input type="text"/>		

Lubricant	<input type="radio"/> Other
<input type="radio"/> Standard prelubrication by Ewellix, as stated in the catalogue.	Please specify:

Sketch of the application (or attach a drawing)

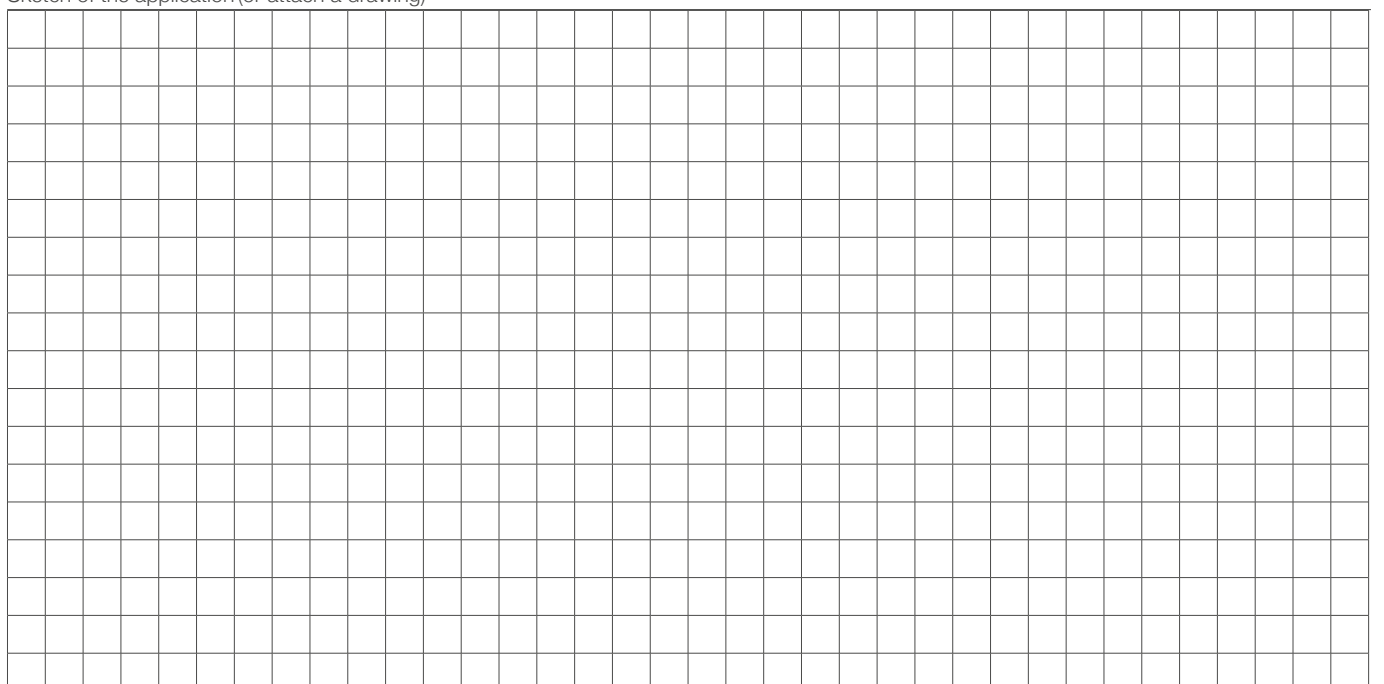

Product details

Product designation (if already known)

Carriage type



Rail type



Preload class

<input type="radio"/> T0 (Zero preload)	<input type="radio"/> T1 (Light preload 2% C)	<input type="radio"/> T2 (Medium preload 8% C)
---	---	--

Precision class

<input type="radio"/> P5 (Standard)	<input type="radio"/> P3 (Medium)	<input type="radio"/> P1 (High)
-------------------------------------	-----------------------------------	---------------------------------

Needed accessories

- Adapter plate (LLTHZ PL)
- Lubrication connector (LLTHZ VN UA)
- Lube element (LLTHZ S6)
- Assembly tool for metal plugs(LLTHZ D6)



ewellix.com

© Ewellix

All contents of this publication are the property of Ewellix, and may not be reproduced or given to third parties (even extracts) without permission. Although great care has been taken in the production of this catalog, Ewellix does not take any responsibility for damage or other loss resulting from omissions or typographical errors. The photo may differ slightly in appearance from the actual product. Due to continuous improvements being made in our products, the product's appearance and specifications are subject to change without notice.

PUB NUM IL-06004/1-EN-May 2020

SKF and SKF logo are trademarks of the SKF Group