



Special Bike Tools Catalogue



Beta has always been closely connected with the cycling world; our history winds along fabulous roads in one of the most cycling-oriented areas. Our company was first established in Erba, where the Colle del Ghisallo downhill road ends. The Madonna del Ghisallo is the Tour of Lombardy's crucial climb. **The Madonna del Ghisallo Sanctuary and the Cycling Museum** the world's best known and busiest destinations for cyclists.



Cycling Museum

Madonna del Ghisallo Sanctuary



The **Agostoni Cup**, the most important race of Trittico Lombardo, has been held on the roads around our current headquarters in Sovico for over 70 years, the greatest champions having crossed the finishing line first.





Agostoni Cup Finish – Lissone

We also have special consideration for the women’s world; we are a proud sponsor of the **Giro Rosa**, which honoured us by starting in our plant in Sovico in summer 2018.



Giro Rosa Start - Sovico

We partner UAE Team Emirates, which is led by the General Manager, Giuseppe Saronni, and competes at UCI World Tour level.

Valerio Conti, Maglia Rosa
A UAE mechanic at work





80°



For over **80 years** we have been Italy's leader in the design and production of professional working tools and instruments. We have **over 600 staff**, men and women employed in **3 factories** in Italy and in the branches in Europe, Asia and South America. We rely on a distribution network boasting no less than **8 commercial branches**, self-owned logistic facilities and over 200 distributors, to be active in the international market, thereby reaching professional users worldwide every day. Beta Utensili's catalogue comprises **28 product families** and over **12,000 coded items**.

28

FAMILIES

Each professional need finds an effective solution.



12.000 ITEMS

Beta produces tools for professional mechanics, from industrial maintenance to car repairs, and for all those whose hobbies are much more than a simple pastime.



3 FACTORIES

Sovico (Monza Brianza)



Castiglione d'Adda (Lodi)



Sulmona (L'Aquila)



600 STAFF

8 SUBSIDIARIES

*Active in over
100 countries
worldwide*

*Beta's far-reaching
distribution network serves
professional users
across the world.*



WWW.BETA-TOOLS.COM

An "easy" and complete website where you can find our updated catalogues, latest news, promotions and all our technical product information (manuals, spare parts and demo videos, which can also be found on YouTube)



A specific app of all the Beta catalogues for IOS and Android.

MADE IN ITALY



This “Special on Bicycle Tools”, which is meant for cycling professionals, contains an accurate selection of bicycle maintenance tools, selected from Beta’s comprehensive catalogue.

As well as special products, it features three main sections, dealing with general garage tools, garage equipment combinations, technical wear and bicycles under the brand name Beta respectively.



FRAME



7÷12



CENTRAL MOVEMENT

12÷15



BRAKES

16



WHEELS

17÷23



TRANSMISSION

24÷25



WRENCHES

27÷28, 30



SCREWDRIVERS, MALE-END

28÷31



WRENCHES AND BITS

37÷39



SOCKETS AND ACCESSORIES

31÷33



TORQUE WRENCHES

33÷34



PLIERS AND NIPPERS

34÷36



HAMMERS

39÷40



MEASURING TOOLS

40÷41



GENERAL MAINTENANCE TOOLS

41÷45



CONTAINERS AND ASSORTMENTS

47÷51



WORKSHOP EQUIPMENT

52÷55

ALPHANUMERIC INDEX

| | | | |
|-------------|----|------------|----|
| 1 | | | |
| 111 | 27 | 1767PMC | 41 |
| 111G | 27 | 1771 | 42 |
| 142 | 28 | 1772R | 42 |
| 142/B6 | 28 | 1838/11LED | 44 |
| 142/SC9I | 28 | 1838COB | 44 |
| 1009L/A | 35 | 1838FLASH | 43 |
| 1032 | 35 | 1895 | 44 |
| 1034 | 35 | 2 | |
| 1036 | 35 | 2028/VV | 47 |
| 1038 | 35 | 2029/VV | 47 |
| 1047 | 34 | 2250-0 | 45 |
| 1048 | 34 | 3 | |
| 1081 | 36 | 334 | 36 |
| 1084 | 36 | 334R | 37 |
| 1128BCX | 37 | 3912P | 8 |
| 1136 | 36 | 3912T | 7 |
| 1150 | 35 | 3916MM | 9 |
| 1166 | 36 | 3921 | 10 |
| 1168 | 36 | 3923 | 10 |
| 1201 | 37 | 3927 | 8 |
| 1201N | 37 | 3932U | 24 |
| 1202 | 37 | 3935 | 24 |
| 1202N | 37 | 3937 | 25 |
| 1203/D7 | 37 | 3948 | 13 |
| 1207TX | 38 | 3952 | 11 |
| 1207TX/D7 | 38 | 3952/S7 | 11 |
| 1256/C36-2 | 39 | 3953 | 13 |
| 1260 | 38 | 3955 | 12 |
| 1260N | 38 | 3961 3,2 | 17 |
| 1262 | 38 | 3961 3,3 | 17 |
| 1262N | 38 | 3961 3,5 | 17 |
| 1263/D8 | 38 | 3961U | 18 |
| 1266BP | 39 | 3962MV | 18 |
| 1266BP/S8 | 39 | 3962SH | 18 |
| 1370 | 39 | 3963P | 19 |
| 1370T | 39 | 3964 | 19 |
| 1390 | 39 | 3965 | 20 |
| 1390R | 40 | 3965C | 20 |
| 1458 | 34 | 3967 | 21 |
| 1599F | 42 | 3969 | 21 |
| 1650 | 40 | 3969K3 | 21 |
| 1651DGT | 40 | 3971 | 14 |
| 1692 | 40 | 3972 | 14 |
| 1695XS | 40 | 3973/1 | 15 |
| 1696 | 40 | 3973/2 | 15 |
| 1696B | 41 | 3973/3 | 15 |
| 1716A | 43 | 3973/4 | 15 |
| 1716P | 43 | 3973PF | 14 |
| 1716Q | 43 | 3975 | 12 |
| 1716R | 43 | 3984/1 | 22 |
| 1716U | 43 | 3984/2 | 22 |
| 1719BMA...M | 41 | 3984/3 | 22 |
| 1719BMA...Q | 41 | 3984/4 | 23 |
| 1719BMA...R | 42 | 3984/5 | 23 |
| 1719BMA6/S5 | 42 | 3984/6 | 23 |
| 1719BMA...T | 41 | 3991 | 16 |
| 1719BMA...P | 41 | 3992 | 16 |
| 1719BMA8/S5 | 42 | 4 | |
| 1726 | 42 | 42 | 27 |
| 1728BM | 42 | 42/B9 | 27 |
| 1737NX | 41 | 42/S17 | 27 |
| 1762 | 41 | 42/SC9I | 27 |
| | | 42/SP15 | 27 |
| | | 5 | |
| | | 55/B8 | 27 |
| | | 5980U/BIKE | 51 |
| | | 6 | |
| | | 605E | 33 |
| | | 666N | 34 |
| | | 8 | |
| | | 860/C27 | 31 |
| | | 9 | |
| | | 96 | 28 |
| | | 96/BG7 | 28 |
| | | 96/BGS7 | 28 |
| | | 96/SC9 | 28 |
| | | 96/SC12 | 28 |
| | | 96BPC | 29 |
| | | 96BPC/SC9 | 29 |
| | | 96T | 29 |
| | | 96T/S6 | 29 |
| | | 96T/S11 | 29 |
| | | 96T/SP11 | 29 |
| | | 96TBP | 29 |
| | | 96TBP/S6 | 29 |
| | | 97TX | 30 |
| | | 97TX/SC8 | 30 |
| | | 97TTX | 30 |
| | | 97TTX/S6 | 30 |
| | | 97TTX/S8 | 30 |
| | | 900ME/SB8 | 31 |
| | | 900TX/SB8 | 32 |
| | | 900/21 | 31 |
| | | 900/25 | 31 |
| | | 900/42 | 31 |
| | | 900/55 | 31 |
| | | 900/C39 | 32 |
| | | 900/SB13 | 31 |
| | | 910A/C16 | 32 |
| | | 920A/C20X | 33 |
| | | 920A/SB8 | 33 |
| | | 920A/SB13 | 33 |
| | | 920/22 | 32 |
| | | 920/25 | 32 |
| | | 920/42 | 33 |
| | | 920/55 | 33 |
| | | 941 | 30 |
| | | 941/S7 | 30 |
| | | C | |
| | | C13 | 47 |
| | | C20L | 47 |
| | | CP17 | 47 |
| | | C24S/5 | 49 |
| | | C24S/6 | 49 |
| | | C24S/7 | 49 |
| | | C24S/8 | 49 |
| | | C24SL | 49 |
| | | C41H | 48 |
| | | C41S | 48 |
| | | C55 | 54 |
| | | C55AB | 55 |
| | | C55PB/3 | 55 |
| | | C57SA | 50 |
| | | C57SB | 50 |
| | | C57SP | 51 |

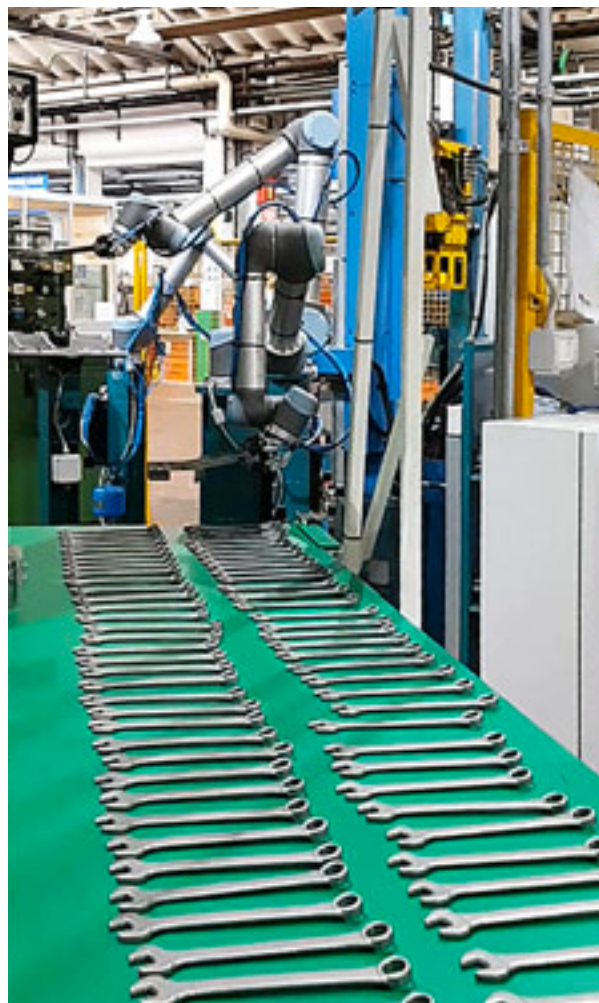



**DEDICATED
BIKE TOOLS**

BIKO ZONE
700

NOTAN



3912T

MADE IN ITALY

TOP WORKSHOP WORKBENCH FOR BICYCLE MAINTENANCE

- With support for central movement
- Tool drawer
- Bicycle can be fixed without rear wheel
- Supports specially designed for BMX bicycles

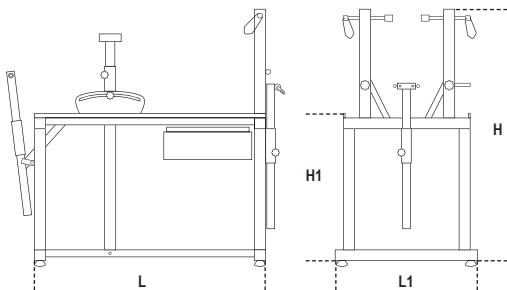

| H mm | L mm | L1 mm | H1 mm | kg | Code |
|------|------|-------|-------|----|-----------|
| 1010 | 910 | 580 | 610 | 47 | 039120010 |



- Professional workbench for bicycle assembly and maintenance.
- Allows you to work with both installed and removed wheels.
- Its weight (47 kg) provides both stability and sturdiness.



Stable, secure top for central movement.

Tool drawer allows you to always have everything within reach.





3912P

MADE IN ITALY

PRO WORKSHOP WORKBENCH FOR BICYCLE MAINTENANCE

- With support for central movement
- Bicycle can be fixed without rear wheel
- Supports specially designed for BMX bicycles

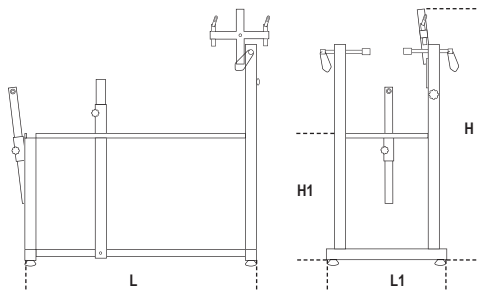

| H mm | L mm | L1 mm | H1 mm | kg | Code |
|------|------|-------|-------|----|-----------|
| 1000 | 785 | 455 | 590 | 21 | 039120110 |

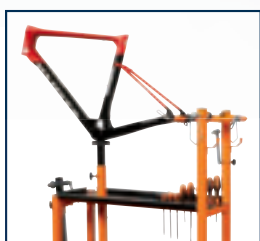

- Stable, secure workbench for bicycle assembly and maintenance.
- Allows you to work with both installed and removed wheels.



3927

MADE IN ITALY

HANDLEBAR CLAMP

- A must-have tool for maintenance jobs on stands without fork clamps
- Ideal for working with single-sided clamp **3916MM**, it allows you to hold handlebar in upright position, thereby avoiding annoying vibration.



| L mm | g | Code |
|------|-----|-----------|
| 365 | 405 | 039270010 |



3916MM

MADE IN ITALY

WORKSHOP SINGLE-SIDED CLAMP FOR BICYCLE MAINTENANCE

- Clamp can be rotated 360°
- Plastic tool tray
- Steel plate for unparalleled firmness
- Adjustable height

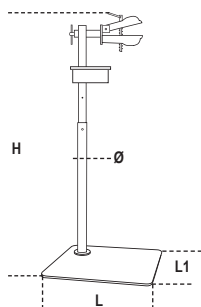

| H mm | Ø mm | L mm | L1 mm | kg | Code |
|-----------|------|------|-------|----|-----------|
| 1230÷1380 | 45 | 600 | 600 | 29 | 039160110 |

- Professional clamp suitable for workshop jobs with limited space available.
- The professional revolving clamp allows **360°** jobs, with safe bicycle rotation.
- The coated clamp jaws allow the clamped surface to be protected.



The tool tray is vertically adjustable.

The large, sturdy, heavy base allows safe jobs, even with E-BIKE.





3921

DERAILLEUR HANGER ALIGNMENT GAUGE

- Adjustable, for wheel 20" ÷ 29"
- A must-have tool for checking derailleur hanger alignment and dealing with gear shifting problems

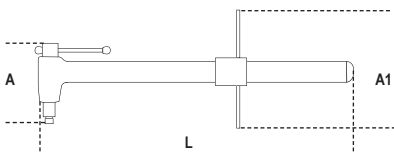
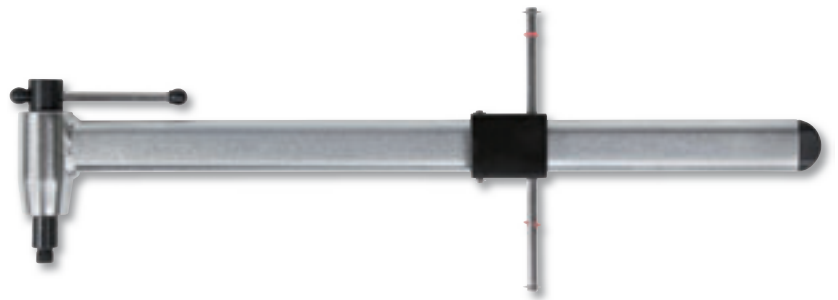

| L mm | A mm | A1 mm | g | Icon |
|------|------|-------|-----|-----------|
| 440 | 115 | 165 | 750 | 039210010 |



3923

BLADE GUIDE TOOL FOR CUTTING AIRFOIL SHAPED SEATPOSTS UP TO 80 MM AND TUBES 1" ÷ 1.1/2"

- Fixing through knurled clamp

Specifically designed to work on tubes and seatposts, including built-in and airfoil-shaped ones.

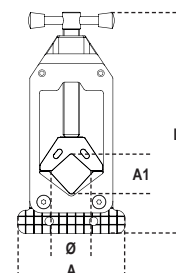

| L mm | A1 max mm | Ø max mm | A mm | g | Icon |
|------|-----------|----------|------|-----|-----------|
| 160 | 80 | 45 | 77,5 | 485 | 039230010 |





3952

MADE IN ITALY

SIMPLE CONE WRENCH, CHROME-PLATED

- Reduced thickness

Chromium-plated finish, reduced thickness (2 mm) and PVC handle coating allow the key to be used for a variety of bicycle maintenance purposes.



| mm | L mm | S mm | A mm | g | |
|----|------|------|------|----|-----------|
| 13 | 205 | 2 | 42,5 | 76 | 039520013 |
| 14 | 205 | 2 | 43,5 | 76 | 039520014 |
| 15 | 205 | 2 | 44,5 | 78 | 039520015 |
| 16 | 205 | 2 | 45,5 | 78 | 039520016 |
| 17 | 205 | 2 | 46,5 | 78 | 039520017 |
| 18 | 205 | 2 | 47,5 | 78 | 039520018 |
| 19 | 205 | 2 | 48,5 | 79 | 039520019 |
| 20 | 205 | 2 | 49,5 | 82 | 039520020 |
| 21 | 205 | 2 | 49,5 | 82 | 039520021 |
| 22 | 205 | 2 | 50,5 | 82 | 039520022 |
| 24 | 205 | 2 | 51,5 | 84 | 039520024 |

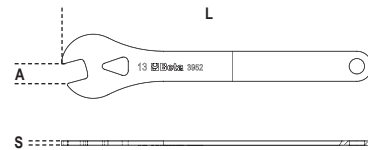

3952/S7

MADE IN ITALY

SET OF 7 SIMPLE CONE WRENCHES

13-14-15-16-17-18-19 mm

| g | |
|-----|-----------|
| 450 | 039520207 |





3955

MADE IN ITALY

OPEN END WRENCHES FOR UNIVERSAL HEADSETS, CHROME-PLATED

- Reduced thickness

Heat treatment and chromium-plated finish translate into remarkable durability, even in case of heavy-duty use.

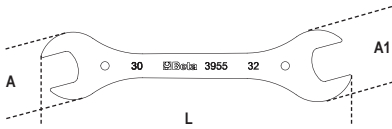

| mm | L mm | A mm | A1 mm | S mm | g | |
|-------|------|------|-------|------|-----|-----------|
| 30x32 | 292 | 63,5 | 67,5 | 4 | 278 | 039550108 |
| 32x36 | 319 | 63,5 | 76,0 | 4 | 330 | 039550114 |



3975

BEARING CUP PRESS

- For headset cup assembly, compatible with headset cups 1", 1.1/8", 1.1/4", 1.1/2" and 2"

Do not use with "zero stack" tubes



| L mm | Ø mm | Ø1 " | Ø2 " | Ø3 " | Ø4 " | Ø5 " | kg | |
|------|------|------|-------|-------|-------|------|-----|-----------|
| 360 | 16x1 | 1 | 1.1/8 | 1.1/4 | 1.1/2 | 2 | 2,7 | 039750010 |





3948

CRANK EXTRACTOR

- For 14 mm nuts
- Beta's crank extractor with interchangeable adapter can be used for square and grooved pins

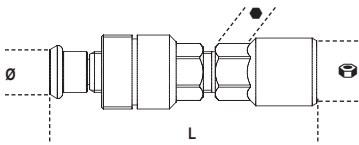

| mm | L mm | Ø mm | mm | g | |
|----|------|------|----|-----|-----------|
| 14 | 79 | 20 | 15 | 114 | 039480015 |



3953

MADE IN ITALY

PEDAL WRENCH, CHROME-PLATED

- Reduced thickness
- PVC handle

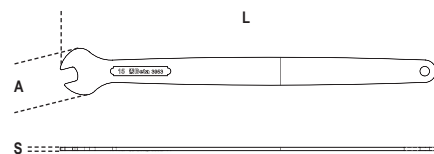

Its length (400 mm) and dedicated heat treatment allow intensive, prolonged use.

| mm | L mm | S mm | A mm | g | |
|----|------|------|------|-----|-----------|
| 15 | 401 | 4 | 50,5 | 378 | 039530015 |





3971

WRENCH FOR SHIMANO® PLASTIC BOLTS

- For installing and removing 8-notch counterbalance cap of Shimano® Hollowtech II cranksets
- Can also be used with 8 mm hexagon key wrench for increased force

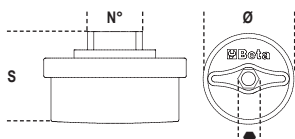

| N° | mm | Ø mm | S mm | g | |
|----|----|------|------|----|-----------|
| 8 | 8 | 38,8 | 25 | 68 | 039710010 |



3972

BOTTOM BRACKET REMOVAL WRENCH

- Suitable for Shimano® Hollowtech II, Campagnolo® Ultra-torque, FSA®, SRAM®
- 2PVC handle

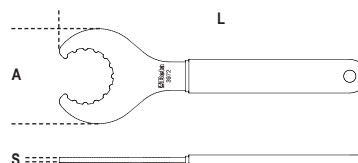

| L mm | A mm | S mm | g | |
|------|------|------|-----|-----------|
| 252 | 78 | 4 | 267 | 039720010 |



3973PF

PRESS-FIT BEARING REMOVAL TOOL

- Suitable for inside Ø 24 mm and 30 mm

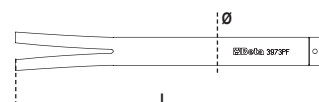

| L mm | Ø mm | g | |
|------|------|-----|-----------|
| 240 | 21,5 | 227 | 039730001 |





3973/1 1/2"

16-NOTCH BOTTOM BRACKET REMOVAL SOCKET

- Suitable for Shimano® XTR BB93, Dura-Ace® BB9000
- The 1/2" square drive and the 24 mm hexagon drive provide different solutions for use

| A1 mm | mm | L mm | g | |
|-------|----|------|-----|-----------|
| 12 | 24 | 34 | 115 | 039730010 |

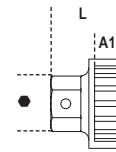

3973/2 1/2"

16-NOTCH BOTTOM BRACKET REMOVAL SOCKET

- Suitable for Shimano® BBR60 (Ultegra® 11 speeds)
- The 1/2" square drive and the 24 mm hexagon drive provide different solutions for use

| A1 mm | mm | L mm | g | |
|-------|----|------|-----|-----------|
| 13,5 | 24 | 35 | 114 | 039730020 |

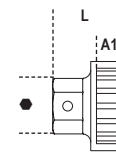

3973/3 1/2"

16-NOTCH BOTTOM BRACKET REMOVAL SOCKET

- Suitable for Shimano® Hollowtech II, Campagnolo® Ultra-torque, FSA®, SRAM®
- The 1/2" square drive and the 24 mm hexagon drive provide different solutions for use

| A1 mm | mm | L mm | g | |
|-------|----|------|-----|-----------|
| 15,3 | 24 | 53,5 | 220 | 039730030 |

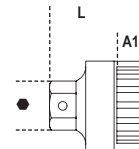

3973/4 1/2"

20-NOTCH BOTTOM BRACKET REMOVAL SOCKET WITH CENTRAL PIN, NICKEL-PLATED

- Suitable for Shimano® and ISIS
- The 1/2" square drive and the 24 mm hexagon drive provide different solutions for use

| A1 mm | mm | L mm | g | |
|-------|----|------|-----|-----------|
| 30 | 24 | 55 | 164 | 039730040 |

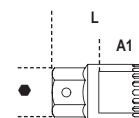



3991

MADE IN ITALY

LEVER FOR PUSHING BACK DISC BRAKE PADS, CHROME-PLATED

- 2PVC handle
- The flat, chromium-plated surface prevents brake pistons from getting damaged



| L mm | A mm | α | S mm | \bar{m} g | |
|------|------|----------|------|-------------|-----------|
| 222 | 36 | 7° | 4 | 200 | 039910010 |

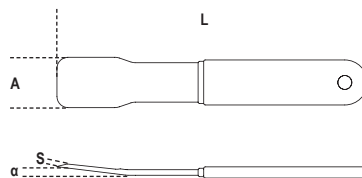

3992

DISC BRAKE STRAIGHTENER, CHROME-PLATED

- 2PVC handle
- The different grooves, with different angles, allow you to work in any situation, including the toughest ones



| L mm | S mm | A mm | A1 mm | \bar{m} g | |
|------|------|------|-------|-------------|-----------|
| 234 | 4 | 55 | 2,2 | 249 | 039920010 |

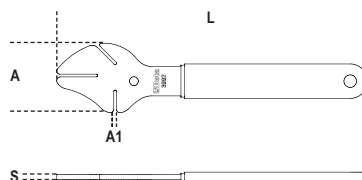



3961 3,2

SPOKE WRENCH, BLACK, 3.2 mm

- Coloured band for ease of identification
- The different colour allows quick, accurate size identification

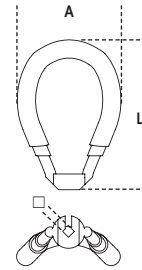

| □ mm | L mm | A mm | g | □ |
|------|------|------|----|-----------|
| 3,2 | 57 | 40 | 20 | 039610032 |



3961 3,3

SPOKE WRENCH, GREEN, 3.3 mm

- Coloured band for ease of identification
- The different colour allows quick, accurate size identification

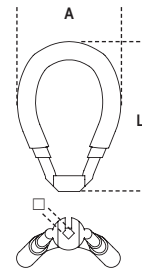

| □ mm | L mm | A mm | g | □ |
|------|------|------|----|-----------|
| 3,3 | 57 | 40 | 20 | 039610033 |



3961 3,5

SPOKE WRENCH, RED, 3.5 mm

- Coloured band for ease of identification
- The different colour allows quick, accurate size identification

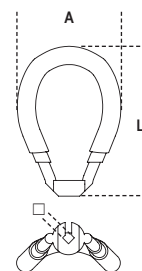

| □ mm | L mm | A mm | g | □ |
|------|------|------|----|-----------|
| 3,5 | 57 | 40 | 20 | 039610035 |



3961U

PROFESSIONAL SPOKE WRENCH, 3.2 - 4.0 mm

- Ergonomic rubber handle
- Allows most used sizes to be always at reach

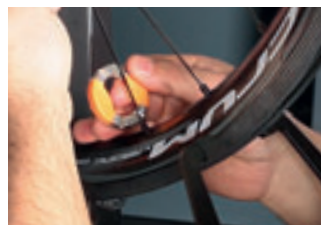
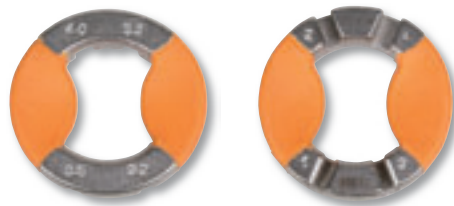

| □ mm | 👤 g | 📦 |
|-----------|-----|-----------|
| 3,2 - 4,0 | 40 | 039610100 |



3962SH

DOUBLE SPOKE WRENCH FOR SHIMANO®

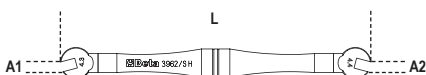

| L mm | A1 mm | A2 mm | 👤 g | 📦 |
|------|-------|-------|-----|-----------|
| 132 | 4,3 | 4,4 | 58 | 039620010 |



3962MV

DOUBLE SPOKE WRENCH FOR MAVIC®

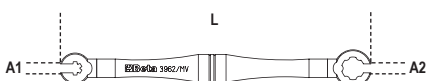

| L mm | A1 mm | A2 mm | 👤 g | 📦 |
|------|-------|-------|-----|-----------|
| 135 | 4,3 | 8,4 | 60 | 039620020 |



3963P

SPECIAL WRENCH FOR FLAT SPOKES

- Useful for installing flat spoke wheels.
- 6 different openings hold a wide range of flat spokes, preventing them from twisting

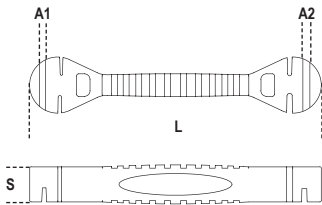

| L mm | S mm | A1 mm | A2 mm | g | Part No. |
|------|------|-------|-------|----|-----------|
| 129 | 15,5 | 2,2 | 2,5 | 31 | 039630010 |



3964

SPECIAL NIPPLE DRIVER

- Allows nipples to be screwed while wheel spokes are being installed
- With rotating handle for unparallelled operating comfort

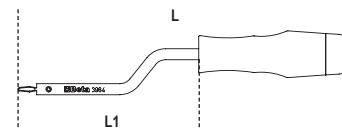
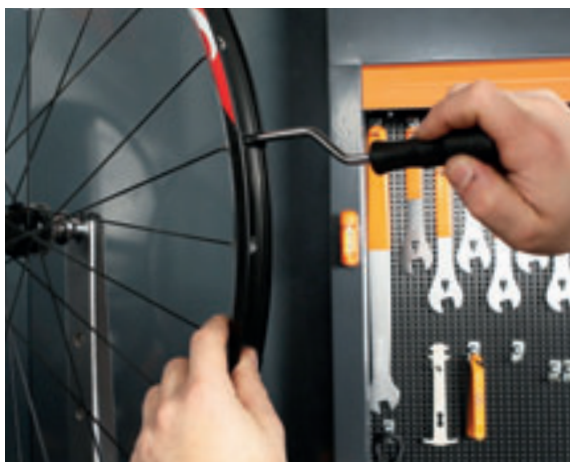

Supplied with a spare spring in handle

| L mm | L1 mm | g | Part No. |
|------|-------|----|-----------|
| 170 | 89 | 40 | 039640010 |





3965

WHEEL ALIGNMENT GAUGE, Ø 20" ÷ 29"

- Suitable for working on road, mountain bike and BMX wheels
- Can also be used with installed tyres
- Sliding pin



| L mm | g | |
|------|-----|-----------|
| 680 | 550 | 039650010 |



3965C

PROFESSIONAL WHEEL TRUING STAND

- Can be fixed onto both a workbench, with supplied clamps, and into a vice
- For Ø 20" ÷ 29" (29" without tyre)
- Through axle hub adapter, 10 ÷ 20 mm
- Can be used with hub spacings ranging from 85 mm to 195 mm



Supplied plates allow secure, stable fixing to workbenches

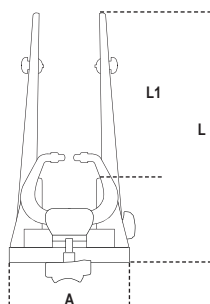

| L mm | L1 mm | A mm | kg | |
|------|-------|------|-----|-----------|
| 500 | 380 | 285 | 7,3 | 039650110 |



3967

MADE IN ITALY

SPROCKET REMOVAL WRENCH WITH CHAIN WHIP

- Caters for up to 11 speed cassettes
- 2PVC handle

Also suitable for fixed bicycles

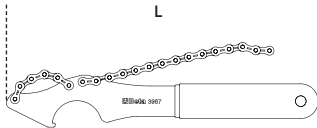

| L mm | S mm | g | |
|------|------|-----|-----------|
| 289 | 4 | 245 | 039670010 |



3969

STEEL TYRE LEVER

- 200 mm long
- Orange handle
- Suitable for heavy duty jobs

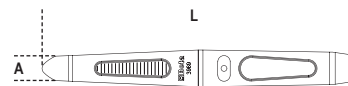

| L mm | A mm | g | |
|------|------|----|-----------|
| 200 | 15,6 | 79 | 039690010 |



3969K3

KIT WITH 3 TYRE LEVERS, MADE OF PLASTIC

- Suitable for both amateurs during their rides and mechanics in the workshop



| L mm | g | |
|------|----|-----------|
| 113 | 30 | 039690130 |





3984/1

BMX FREEWHEEL REMOVAL WRENCH,
4 GRAFTS, NICKEL-PLATED

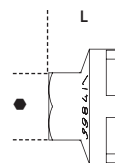

| L mm | ● mm | 📏 g | 🏠 |
|------|------|-----|-----------|
| 25,5 | 24 | 78 | 039840010 |



3984/2

SHIMANO® FREEWHEEL REMOVAL WRENCH

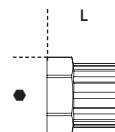

| L mm | ● mm | 📏 g | 🏠 |
|------|------|-----|-----------|
| 26 | 24 | 28 | 039840020 |



3984/3 12"

SHIMANO® FREEWHEEL REMOVAL WRENCH,
CASSETTE WITH PIN GUIDE, NICKEL-PLATED

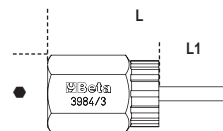
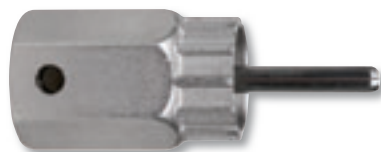

| L mm | L1 mm | ● mm | 📏 g | 🏠 |
|------|-------|------|-----|-----------|
| 65 | 25 | 24 | 74 | 039840030 |



3984/4

CAMPAGNOLO FREEWHEEL REMOVAL WRENCH, WITH GUIDE PIN, PHOSPHATIZED

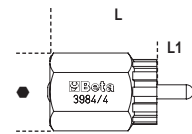

| L mm | L1 mm | ● mm | g | |
|------|-------|------|----|-----------|
| 51 | 13 | 24 | 49 | 039840040 |



3984/5 12"

FREEWHEEL REMOVAL WRENCH, 2 GRAFTS

- For SunTour wheels
- The 1/2" square drive and the 24 mm hexagon drive provide different solutions for use

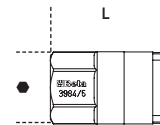
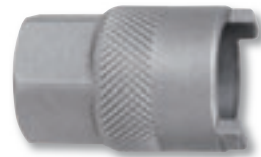

| L mm | ● mm | g | |
|------|------|----|-----------|
| 38 | 21 | 68 | 039840050 |



3984/6 12"

FREEWHEEL REMOVAL WRENCH, 4 GRAFTS

- For SunTour wheels
- The 1/2" square drive and the 21 mm hexagon drive provide different solutions for use.

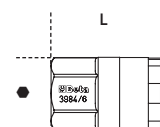

| L mm | ● mm | g | |
|------|------|----|-----------|
| 36 | 21 | 64 | 039840060 |



3932U

PROFESSIONAL CHAIN TOOL COMPATIBLE
WITH CHAINS FROM 5 TO 11 SPEEDS



| L mm | L1 mm | g | Part No. |
|------|-------|-----|-----------|
| 164 | 115 | 210 | 039320011 |



3935

CHAIN WEAR INDICATOR

- Suitable for checking chain elongation with "passes/does not pass" system
- $0\% \div 0.75\%$: chain does not need to be replaced
- $0.8\% \div 1\%$: chain needs to be replaced

- **A worn chain makes poor shifting and accelerates sprocket wear**
- **Poor chain maintenance can cause sudden breakage**

Beta's gauge is designed to immediately indicate wear and whether the chain has been subjected to such elongation as to require replacement.

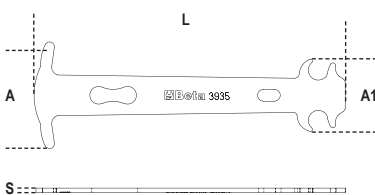

| L mm | A mm | A1 mm | S mm | g | Part No. |
|------|------|-------|------|----|-----------|
| 120 | 48 | 32 | 1,9 | 31 | 039350010 |





3937

MISSING LINK PLIERS

- 2PVC handle
- Useful for removing and installing missing link

Dirt and corrosion may make it difficult to remove the chain. Pliers 3937 deal with the problem simply and promptly.

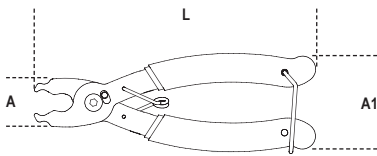

| L mm | A mm | A1 mm | g | 039370010 |
|------|------|-------|-----|-----------|
| 170 | 59 | 29 | 153 | |



GENERAL MANTEINACE TOOLS



42

COMBINATION WRENCHES, OPEN AND OFFSET RING ENDS

DIN 3113 UNI-ISO 7738



| mm | L mm | |
|-------|------|-----------|
| 6x6 | 95 | 000420006 |
| 7x7 | 105 | 000420007 |
| 8x8 | 116 | 000420008 |
| 9x9 | 127 | 000420009 |
| 10x10 | 137 | 000420010 |
| 11x11 | 148 | 000420011 |
| 12x12 | 158 | 000420012 |
| 13x13 | 169 | 000420013 |
| 14x14 | 180 | 000420014 |
| 15x15 | 190 | 000420015 |
| 16x16 | 201 | 000420016 |
| 17x17 | 212 | 000420017 |
| 18x18 | 222 | 000420018 |
| 19x19 | 233 | 000420019 |
| 20x20 | 243 | 000420020 |
| 21x21 | 254 | 000420021 |
| 22x22 | 264 | 000420022 |
| 24x24 | 275 | 000420024 |



42/B9

6-7-8-10-11-13-14-17-19 mm

737 g 000420064

42/S17

6-7-8-9-10-11-12-13-14-15-16-17-18-19-20-21-22 mm

1,6 kg 000420065



42/SP15

6-7-8-9-10-11-12-13-14-15-16-17-18-19-20-21-22 mm

2,1 kg 000420078



42/SC9I

8-10-11-12-13-14-15-17-19 mm

950 g 000420087



55/B8

6x7-8x9-10x11-12x13-14x15-16x17-18x19-20x22 mm

800 g 000550158

111

ADJUSTABLE WRENCHES WITH SCALES, CHROME-PLATED

- Movable jaw opening with right-hand rotation of pin
 - Head angled at 22.5 degrees, with mm and inch scale
- DIN 3117 ISO 6787

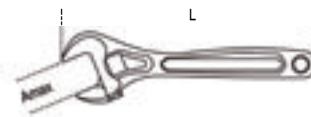

| L mm | L " | A max mm | |
|------|-----|----------|-----------|
| 100 | 4 | 15 | 001110010 |
| 150 | 6 | 24 | 001110015 |
| 200 | 8 | 28 | 001110020 |
| 250 | 10 | 34 | 001110025 |
| 300 | 12 | 35 | 001110030 |

111G

ADJUSTABLE WRENCHES WITH SCALES CHROME-PLATED

- Movable jaw opening with right-hand rotation of pin
 - Ergonomic handle
 - mm and inch scale
- DIN 3117 ISO 6787



| L mm | L " | A max mm | |
|------|-----|----------|-----------|
| 200 | 8 | 28 | 001110620 |
| 250 | 10 | 34 | 001110625 |

142

REVERSIBLE RATCHETING COMBINATION WRENCHES



| mm | L mm | 001420006 |
|-------|------|-----------|
| 6x6 | 136 | 001420006 |
| 7x7 | 136 | 001420007 |
| 8x8 | 136 | 001420008 |
| 9x9 | 143 | 001420009 |
| 10x10 | 159 | 001420010 |
| 11x11 | 168 | 001420011 |
| 12x12 | 174 | 001420012 |
| 13x13 | 180 | 001420013 |
| 14x14 | 190 | 001420014 |
| 15x15 | 200 | 001420015 |
| 16x16 | 216 | 001420016 |
| 17x17 | 233 | 001420017 |
| 18x18 | 239 | 001420018 |
| 19x19 | 248 | 001420019 |
| 21x21 | 285 | 001420021 |
| 22x22 | 285 | 001420022 |
| 24x24 | 325 | 001420024 |



142/B6

8-10-13-14-17-19 mm

800 g 001420066



142/SC9

8-10-11-12-13-14-15-17-19 mm

950 g 001420087



96

OFFSET HEXAGON KEY WRENCHES CHROME-PLATED

ISO 2936

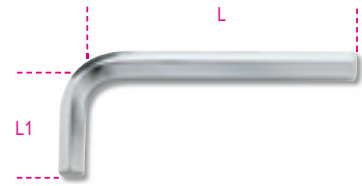

| mm | L mm | L1 mm | 000960013 |
|-----|------|-------|-----------|
| 0,9 | 35 | 8 | 000960013 |
| 1,3 | 39 | 10 | 000960014 |
| 1,5 | 45 | 15 | 000960015 |
| 2 | 50 | 17 | 000960020 |
| 2,5 | 57 | 20 | 000960025 |
| 3 | 64 | 22 | 000960030 |
| 3,5 | 68 | 25 | 000960035 |
| 4 | 72 | 28 | 000960040 |
| 4,5 | 78 | 30 | 000960045 |
| 5 | 83 | 32 | 000960050 |
| 5,5 | 88 | 35 | 000960055 |
| 6 | 94 | 37 | 000960060 |
| 7 | 99 | 40 | 000960070 |
| 8 | 105 | 43 | 000960080 |
| 9 | 111 | 46 | 000960090 |
| 10 | 119 | 49 | 000960100 |
| 11 | 126 | 52 | 000960110 |
| 12 | 134 | 56 | 000960120 |
| 13 | 142 | 62 | 000960130 |
| 14 | 151 | 69 | 000960140 |
| 16 | 165 | 75 | 000960160 |
| 17 | 174 | 79 | 000960170 |



96/BGS7

1,5-2-2,5-3-4-5-6 mm

150 g 000960367

96/BG7

2,5-3-4-5-6-8-10 mm

290 g 000960368



96/SC9

1,5-2-2,5-3-4-5-6-8-10 mm

300 g 000960374



96/SC12

2-2,5-3-3,5-4-4,5-5-6-7-8-9-10 mm

440 g 000960395

96BPC

BALL HEAD OFFSET HEXAGON KEY
WRENCHES CHROME-PLATED

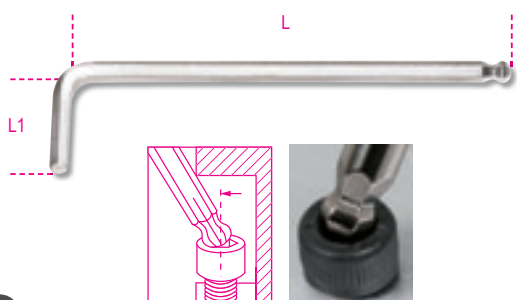

| mm | L mm | L1 mm | 000960340 |
|-----|------|-------|-----------|
| 1,5 | 79 | 13 | 000960340 |
| 2 | 84 | 15 | 000960341 |
| 2,5 | 89 | 17 | 000960342 |
| 3 | 99 | 19 | 000960343 |
| 4 | 108 | 24 | 000960344 |
| 5 | 126 | 27 | 000960345 |
| 6 | 148 | 31 | 000960346 |
| 7 | 157 | 33 | 000960353 |
| 8 | 168 | 35 | 000960347 |
| 10 | 187 | 39 | 000960348 |
| 12 | 220 | 55 | 000960352 |



96BPC/SC9

1,5-2-2,5-3-4-5-6-8-10 mm

400 g 000960354

96TBP

BALL HEAD OFFSET HEXAGON KEY WRENCHES
WITH HIGH TORQUE HANDLES

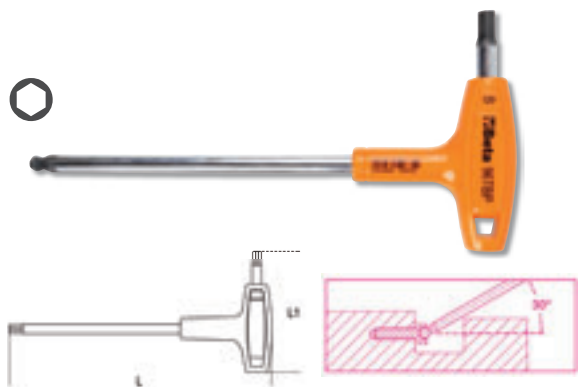

| mm | L mm | L1 mm | 000960685 |
|-----|------|-------|-----------|
| 2,5 | 153 | 55 | 000960685 |
| 3 | 153 | 55 | 000960686 |

| mm | L mm | L1 mm | 000960687 |
|----|------|-------|-----------|
| 4 | 179 | 70 | 000960687 |
| 5 | 200 | 84 | 000960688 |
| 6 | 221 | 103 | 000960689 |
| 8 | 255 | 117 | 000960690 |
| 10 | 285 | 132 | 000960692 |

96TBP/S6

2,5-3-4-5-6-8 mm

525 g 000960694

96T

OFFSET HEXAGON KEY WRENCHES,
WITH HIGH TORQUE HANDLES

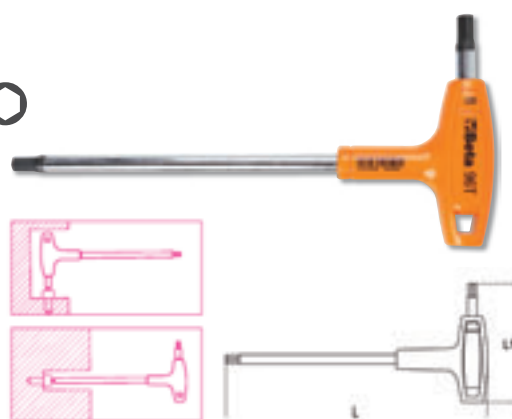

| mm | L mm | L1 mm | 000960934 |
|-----|------|-------|-----------|
| 2 | 139 | 52 | 000960934 |
| 2,5 | 153 | 55 | 000960935 |
| 3 | 153 | 55 | 000960936 |
| 3,5 | 179 | 70 | 000960937 |
| 4 | 179 | 70 | 000960938 |
| 4,5 | 200 | 84 | 000960939 |
| 5 | 200 | 84 | 000960940 |
| 6 | 221 | 103 | 000960941 |
| 7 | 236 | 106 | 000960942 |
| 8 | 255 | 117 | 000960943 |
| 10 | 285 | 132 | 000960945 |

96T/S6

2-2,5-3-4-5-6 mm

500 g 000960952

96T/S11

2-2,5-3-3,5-4-4,5-5-6-7-8-10 mm

1,1 kg 000960951



96T/SP11

2-2,5-3-3,5-4-4,5-5-6-7-8-10 mm

1,5 kg 000960957

97TX

OFFSET KEY WRENCHES,
FOR TORX® HEAD SCREWS



| ⊙ | L mm | L1 mm | 📄 |
|-----|------|-------|-----------|
| T6 | 42 | 16 | 000970006 |
| T7 | 48 | 16 | 000970007 |
| T8 | 48 | 16 | 000970008 |
| T9 | 48 | 16 | 000970009 |
| T10 | 51 | 17 | 000970010 |
| T15 | 54 | 18 | 000970015 |
| T20 | 57 | 19 | 000970020 |
| T25 | 60 | 20 | 000970025 |
| T27 | 64 | 21 | 000970027 |
| T30 | 70 | 24 | 000970030 |
| T40 | 76 | 26 | 000970040 |



97TX/SC8

⊙ T9-T10-T15-T20-T25-T27-T30-T40

120 g 📄 000970064

97TTX

OFFSET KEY WRENCHES WITH HANDLES
FOR TORX® HEAD SCREWS

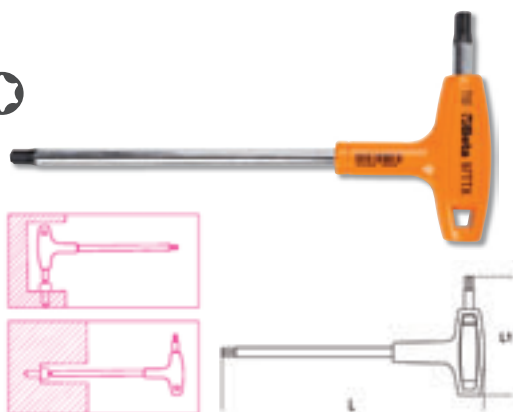

| ⊙ | L mm | L1 mm | 📄 |
|-----|------|-------|-----------|
| T6 | 130 | 52 | 000970706 |
| T7 | 130 | 52 | 000970707 |
| T8 | 139 | 52 | 000970708 |
| T9 | 139 | 52 | 000970709 |
| T10 | 179 | 70 | 000970710 |
| T15 | 179 | 70 | 000970715 |
| T20 | 179 | 70 | 000970720 |
| T25 | 179 | 70 | 000970725 |
| T27 | 200 | 84 | 000970727 |
| T30 | 200 | 84 | 000970730 |
| T40 | 221 | 103 | 000970740 |

97TTX/S6

⊙ T10-T15-T20-T25-T30-T40

380 g 📄 000970791

97TTX/S8

⊙ T8-T10-T15-T20-T25-T27-T30-T40

500 g 📄 000970808



941

HEXAGON / BI-HEX SOCKET WRENCHES,
WITH HIGH TORQUE HANDLES

- deep, hi-torque hexagon nut spinner on long side

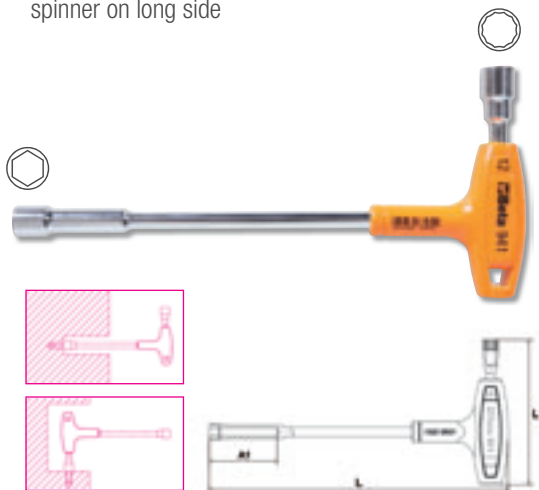

| ⊙ mm | L mm | L1 mm | A1 mm | 📄 |
|-------|------|-------|-------|-----------|
| 7x7 | 200 | 91 | 35 | 009410107 |
| 8x8 | 220 | 107 | 50 | 009410108 |
| 9x9 | 220 | 109 | 50 | 009410109 |
| 10x10 | 236 | 111 | 50 | 009410110 |
| 11x11 | 236 | 114 | 50 | 009410111 |
| 12x12 | 255 | 122 | 50 | 009410112 |
| 13x13 | 255 | 124 | 55 | 009410113 |

941/S7

⊙ 7-8-9-10-11-12-13 mm

1,3 kg 📄 009410170

860/C27

25 BITS, 1 CONNECTOR AND 1 REVERSIBLE RATCHET

- in plastic case



| | | |
|--|--------|-------------------------------|
| | 860/55 | 100 mm |
| | 860LP | 0,5x3-1,0x5,5-1,2x6,5 mm |
| | 860PH | PH1-PH2(x2)-PH3 |
| | 860PZ | PZ1-PZ2(x2)-PZ3 |
| | 860PE | 2-2,5-3-4-5-6 mm |
| | 860TX | T6-T8-T10-T15-T20-T25-T30-T40 |
| | 892/0 | ● 1/4 ■ 1/4 |

| | | | | |
|-----------|----|-----|---|-----------|
| | mm | | g | |
| 150x95x50 | | 785 | | 008600880 |

900/21

1/4" FEMALE AND MALE DRIVE EXTENSION BARS

UNI/ISO 3316 DIN 3123



1/4"

| | | |
|------|------|-----------|
| L mm | ∅ mm | |
| 150 | 11,5 | 009000822 |

900/25

1/4" DRIVE UNIVERSAL JOINT

UNI/ISO 3316 DIN 3123



1/4"

| | | |
|------|------|-----------|
| L mm | ∅ mm | |
| 41 | 12,5 | 009000830 |

900/42

1/4" DRIVE SLIDING T-HANDLE

UNI/ISO 3315 DIN 3122

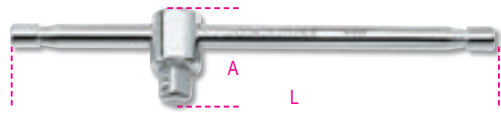

1/4"

| | | |
|------|------|-----------|
| L mm | A mm | |
| 115 | 22 | 009000854 |

900/55

1/4" DRIVE REVERSIBLE RATCHET, 48 TEETH

UNI/ISO 3315 DIN 3122



48 1/4"

| | | | |
|------|------|------|-----------|
| L mm | ∅ mm | A mm | |
| 125 | 25 | 18 | 009000870 |

900/SB13

SET OF 13 HEXAGON HAND SOCKETS, 1/4" FEMALE DRIVE, CHROME-PLATED



1/4"

| | |
|--|-----------|
| | |
| 4-4,5-5-5,5-6-7-8-9 10-11-12-13-14 mm | 009000150 |

900ME/SB8

SET OF 8 SOCKET DRIVERS FOR HEXAGON SCREWS, 1/4" FEMALE DRIVE, CHROME-PLATED



1/4"

| | |
|-----------------------|-----------|
| | |
| 2,5-3-4-5-6-7-8-10 mm | 009000518 |

900TX/SB8

SET OF 8 SOCKET DRIVERS FOR TORX® HEAD SCREWS,
1/4" FEMALE DRIVE, ON SUPPORT

14"



T9-T10-T15-T20
T25-T27-T30-T40

009000730

900/C39

ASSORTMENT OF 11 HEXAGON SOCKETS,
21 BITS AND 7 ACCESSORIES

- Compact easy to carry
- Complete everything that is required in little space
- Functional inserts easy to take out and put in



14" 1/4"

| | | |
|--|-----------|---------------------------------|
| | 900 | 5-5,5-6-7-8-9-10-11-12-13-14 mm |
| | 900/20 | 50 mm |
| | 900/20L | 100 mm |
| | 900/25 | |
| | 900BG/30C | |
| | 900/55 | |
| | 892/0 | |
| | 895/1 | 1/4" □ 1/4" □ |
| | 861LP | 0,6x4,5-1,2x6,5-1,2x8 mm |
| | 861PH | 1-2-3 |
| | 861PZ | 1-2-3 |
| | 861PE | 2,5-3-4-5-6 mm |
| | 861RTX | 10-15-20-25-27-30-40 |

mm

g



150x95x50

785

009000937

910A/C16

ASSORTMENT OF 16 HEXAGON SOCKETS
AND 5 ACCESSORIES



38"

| | | |
|--|--------|--|
| | 910A | 6-7-8-9-10-11-12-13-14-15-16-17-18-19-21 - 22 mm |
| | 910/21 | 125 mm |
| | 910/22 | 250 mm |
| | 910/25 | |
| | 910/42 | |
| | 910/55 | |

mm

kg



335x145x60

2,3

009100936

920/22

1/2" DRIVE EXTENSION BARS

UNI/ISO 3316 DIN 3123



12"

L mm

Ø mm



255

22

009200826

920/25

1/2" DRIVE UNIVERSAL JOINT

UNI/ISO 3316 DIN 3123



12"

L mm

Ø mm



75

12,5

009200830

920/42

1/2" DRIVE SLIDING T HANDLE

UNI/ISO 3315 DIN 3122

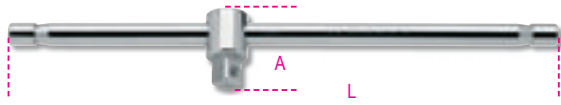

12"

| L mm | A mm | Icon | Part No. |
|------|------|------|-----------|
| 305 | 42 | | 009200854 |

920/55

1/2" DRIVE REVERSIBLE RATCHET, 72 TEETH

UNI/ISO 3315 DIN 3122



72 12"

| L mm | Ø mm | A mm | Icon | Part No. |
|------|------|------|------|-----------|
| 275 | 40 | 43 | | 009200882 |

920A/SB13

SET OF 13 HEXAGON HAND SOCKETS, 1/2" FEMALE DRIVE, ON SUPPORT



12"

| Icon | Part No. |
|------|-----------|
| | 009200040 |

10-11-12-13-14-15-16
17-18-19-20-21-22 mm

920A/SB8

SET OF 8 HEXAGON HAND SOCKETS, 1/2" FEMALE DRIVE, ON SUPPORT



12"

| Icon | Part No. |
|------|-----------|
| | 009200042 |

23-24-25-26-27-28-30-32 mm

920A/C20X

ASSORTMENT OF 20 SOCKETS AND 5 ACCESSORIES



12"

| Icon | Part No. | Dimensions |
|------|----------|--|
| | 920A | 10-11-12-13-14-15-16-17-18-19-20-21-22-23-24-26-27-28-30-32 mm |
| | 920/21 | 125 mm |
| | 920/22 | 255 mm |
| | 920/25 | |
| | 920/42 | |
| | 920/55 | |

| Icon | mm | kg | Icon | Part No. |
|------|------------|-----|------|-----------|
| | 420x185x60 | 5,1 | | 009200950 |

605E

CLICK-TYPE TORQUE WRENCHES WITH REVERSIBLE RATCHETS

- for right-hand and left-hand tightening
- torque accuracy: $\pm 6\%$
- UNI EN 26789 ISO 6789

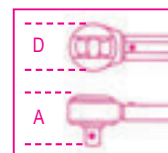

14"

| Nm | Kgfm | lbf.in | Icon | A mm | L mm |
|-----|---------|--------|------|------|------|
| 1÷5 | 0,1÷0,5 | 10÷45 | | 20 | 190 |

| Icon | g | Icon | Part No. |
|------|-----|------|-----------|
| | 180 | | 006050105 |

| Nm | Kgfm | lbf.in | Icon | A mm | L mm |
|------|---------|--------|------|------|------|
| 2÷10 | 0,2÷1,0 | 18÷90 | | 20 | 190 |

| Icon | g | Icon | Part No. |
|------|-----|------|-----------|
| | 180 | | 006050110 |

666N

CLICK-TYPE TORQUE WRENCHES WITH REVERSIBLE RATCHETS

- for right-hand tightening, torque accuracy: $\pm 3\%$
 - scale increased by 60% for improved visibility and setting accuracy
 - torque adjusting speed increased by 40%
 - handle and lens materials resistant to all chemical substances used in automotive sector, industry and aviation
 - red colour of o-ring indicates that wrench is unlocked and torque can be adjusted
 - when not in use, set torque to lowest value of torque wrench range
- UNI EN 26789 ISO 6789



| Nm | Kgfm | lbf.in | ■ | D mm | A mm | L mm |
|-------|------|--------|-----|------|------|------|
| 10÷50 | 1÷5 | 7÷37 | 3/8 | 30 | 33 | 325 |

| g | | ■ | |
|---------------|-----|-----------|--|
| 666N/5 | 660 | 006660005 | |

| Nm | Kgfm | lbf.in | ■ | D mm | A mm | L mm |
|--------|------|--------|-----|------|------|------|
| 20÷100 | 2÷10 | 15÷75 | 3/8 | 30 | 33 | 367 |

| g | | ■ | |
|----------------|-----|-----------|--|
| 666N/10 | 730 | 006660010 | |

| Nm | Kgfm | lbf.in | ■ | D mm | A mm | L mm |
|--------|------|--------|-----|------|------|------|
| 20÷100 | 2÷10 | 15÷75 | 1/2 | 30 | 37 | 367 |

| g | | ■ | |
|-----------------|-----|-----------|--|
| 666N/10X | 800 | 006660011 | |



1047

SLIP JOINT PLIERS, PUSH BUTTON ALIGNMENT



| L mm | A max mm | L1 mm | ■ |
|------------|----------|-------|-----------|
| 180 | 30 | 29 | 010470180 |
| 240 | 36 | 35 | 010470240 |

1048

SLIP JOINT PLIERS, BOXED JOINTS

- slip-proof double layer PVC coated handles
- 9-position model



| L mm | A max mm | L1 mm | ■ |
|------------|----------|-------|-----------|
| 175 | 30 | 29 | 010480010 |
| 250 | 48 | 39 | 010480015 |

1458

EXTERNAL BUTT-ENDED CIRCLIP PLIERS

DIN 5417



| ∅ mm | L mm | ■ |
|---------------|------|-----------|
| 30÷100 | 200 | 014580001 |

1009L/A

EXTRA LONG NEEDLE KNURLED NOSE PLIERS, FOR SPECIAL OPERATIONS

- slip-proof double layer PVC coated handles



| L mm | L1 mm | UNI |
|------|-------|-----------|
| 283 | 80 | 010090008 |

1032

INTERNAL CIRCLIP PLIERS, STRAIGHT PATTERN

- PVC-coated handles
UNI 7914 DIN 5256



| L mm | ∅ mm | UNI |
|---------|-------|-----------|
| 140x0,9 | 8÷12 | 010320013 |
| 140x1,3 | 12÷25 | 010320014 |
| 180 | 19÷60 | 010320017 |

1034

INTERNAL CIRCLIP PLIERS, BENT PATTERN, 90°

- PVC-coated handles
UNI 7914 DIN 5256



| L mm | ∅ mm | UNI |
|---------|-------|-----------|
| 130x0,9 | 8÷12 | 010340013 |
| 130x1,3 | 12÷25 | 010340014 |
| 170 | 19÷60 | 010340017 |

1036

EXTERNAL CIRCLIP PLIERS, STRAIGHT PATTERN

- PVC-coated handles
UNI 7915 DIN 5254

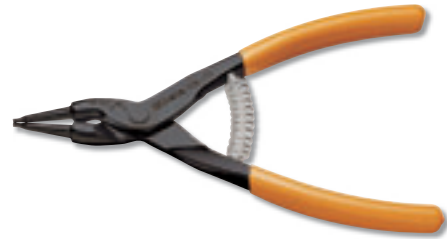

| L mm | ∅ mm | UNI |
|---------|-------|-----------|
| 140x0,9 | 3÷10 | 010360013 |
| 140x1,3 | 10÷25 | 010360014 |
| 175 | 19÷60 | 010360017 |

1038

EXTERNAL CIRCLIP PLIERS, BENT PATTERN, 90°

- PVC-coated handles
UNI 7915 DIN 5254



| L mm | ∅ mm | UNI |
|---------|-------|-----------|
| 135x0,9 | 3÷10 | 010380013 |
| 135x1,3 | 10÷25 | 010380014 |
| 175 | 19÷60 | 010380017 |

1150

COMBINATION PLIERS BRIGHT CHROME-PLATED

- slip-proof double layer PVC coated handles
ISO 5746

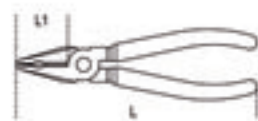

| L mm | L1 mm | W mm | UNI |
|------|-------|------|-----------|
| 160 | 37 | 1,6 | 011500006 |
| 180 | 41 | 1,8 | 011500008 |
| 200 | 45 | 2,0 | 011500010 |



1166

EXTRA LONG NEEDLE KNURLED NOSE PLIERS

- slip-proof double layer PVC coated handles
- ISO 5745

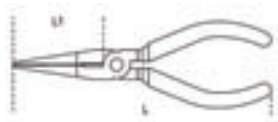
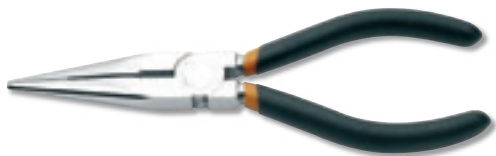

| L mm | L1 mm | ∅ mm | |
|------|-------|------|-----------|
| 160 | 56 | 1,6 | 011660006 |



1168

EXTRA LONG BENT NEEDLE KNURLED NOSE PLIERS

- slip-proof double layer PVC coated handles
- ISO 5745

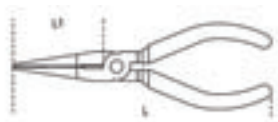

| L mm | L1 mm | ∅ mm | |
|------|-------|------|-----------|
| 160 | 54 | 1,6 | 011680006 |



1081

SEMI-FLUSH CUTTING NIPPERS

- slip-proof double layer PVC coated handles
- for micro-mechanics and heavy-duty electronics



| L mm | L1 mm | |
|------|-------|-----------|
| 125 | 16 | 010810130 |



1084

HEAVY DUTY DIAGONAL CUTTING NIPPERS

- slip-proof double layer PVC coated handles
- UNI/ISO 5749

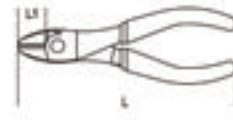

| L mm | L1 mm | ∅ mm | |
|------|-------|------|-----------|
| 140 | 20 | 1,4 | 010840004 |
| 160 | 22 | 1,6 | 010840006 |
| 180 | 25 | 1,8 | 010840008 |



1136

CABLE CUTTER FOR STEEL CABLES

- Ø 5 mm for cable R ≤ 160 Kg/mm²
- Ø 4 mm for mild steel bolts



| L mm | |
|------|-----------|
| 165 | 011360001 |



334

PIPE CUTTER FOR COPPER AND LIGHT ALLOY PIPES

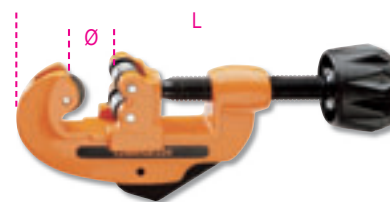

| ∅ mm - " | L mm | |
|--------------------|------|-----------|
| 3÷30 1/8"÷1"1/8 | 150 | 003340001 |

334R

spare cutter wheel for item 334
for copper and light alloy pipes

18 g  003340021



1128BCX

ELECTRICIAN'S SCISSORS, STRAIGHT STAINLESS STEEL BLADES

- with microteeth, cable cutting groove and crimping pliers for tube terminals
- tube terminal crimping: $1 \div 4 \text{ mm}^2$ with reduction unit
- in jointed plastic case



| L mm | L1 mm | mm^2 |  |
|------|-------|---------------|---|
| 155 | 55 | 50 | 011280080 |

1201

SCREWDRIVERS FOR SLOTTED HEAD SCREWS

ISO 2380



| SxAxL mm | L1 mm |  |
|-------------|-------|---|
| 0,4x2,5x50 | 146 | 012010003 |
| 0,5x3x75 | 171 | 012010009 |
| 0,8x4x125 | 221 | 012010033 |
| 1,0x5,5x125 | 234 | 012010042 |
| 1,2x6,5x100 | 220 | 012010048 |

1202

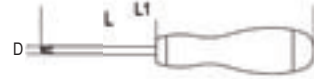

SCREWDRIVERS FOR CROSS HEAD PHILLIPS® SCREWS

UNI/ISO 8764



| PHxDxL mm | L1 mm |  |
|-----------|-------|---|
| 0x3x60 | 156 | 012020003 |
| 1x4,5x80 | 189 | 012020009 |
| 2x6x100 | 220 | 012020018 |

1203/D7

1201  0,5x3x75-0,8x4x100-1,0x5,5x100-1,2x6,5x150 mm
1202  PH0x3x60-PH1x4,5x80-PH2x6x100 mm

600 g  012030007



1201N

SCREWDRIVERS FOR SLOTTED HEAD SCREWS, EXTRA-SHORT SERIES

ISO 2380

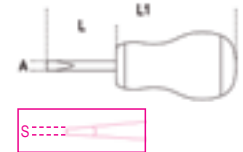

| SxAxL mm | L1 mm |  |
|------------|-------|---|
| 0,8x4x30 | 86,5 | 012010103 |
| 1,2x6,5x30 | 86,5 | 012010106 |

1202N

SCREWDRIVERS FOR CROSS HEAD PHILLIPS® SCREWS, EXTRA-SHORT SERIES

UNI/ISO 8764



| PHxDxL mm | L1 mm |  |
|-----------|-------|---|
| 1x4,5x30 | 86,5 | 012020103 |
| 2x6x30 | 86,5 | 012020106 |

1207TX

SCREWDRIVERS FOR TORX® HEAD SCREWS,
WITH HANDLES

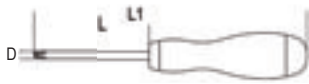

| ⊙ | L mm | L1 mm | D mm | 📄 |
|-----|------|-------|------|-----------|
| T5 | 50 | 150 | 3 | 012070005 |
| T6 | 60 | 156 | 4 | 012070006 |
| T7 | 60 | 156 | 4 | 012070007 |
| T8 | 60 | 156 | 4 | 012070008 |
| T9 | 60 | 156 | 4 | 012070009 |
| T10 | 80 | 189 | 5 | 012070010 |
| T15 | 80 | 189 | 5 | 012070015 |
| T20 | 100 | 209 | 5 | 012070020 |
| T25 | 100 | 209 | 5 | 012070025 |
| T27 | 100 | 220 | 6 | 012070027 |
| T30 | 100 | 220 | 6 | 012070030 |
| T40 | 130 | 262 | 7 | 012070040 |
| T45 | 130 | 262 | 8 | 012070045 |

1207TX/D7

⊙ T6-T8-T10-T15-T20-T25-T30

560 g 📄 012070207



1260

SCREWDRIVERS FOR SLOTTED HEAD SCREWS

UNI/ISO 8764



| SxAxL mm | L1 mm | 📄 |
|-------------|-------|-----------|
| 0,4x2,5x50 | 150 | 012600003 |
| 0,5x3x75 | 175 | 012600009 |
| 0,8x4x100 | 208 | 012600030 |
| 1x5,5x125 | 233 | 012600040 |
| 1,2x6,5x150 | 269 | 012600051 |

1262

SCREWDRIVERS FOR CROSS HEAD PHILLIPS® SCREWS

UNI/ISO 8764

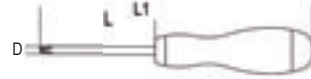

| PHxDxL mm | L1 mm | 📄 |
|-----------|-------|-----------|
| 0x3x60 | 200 | 012620003 |
| 1x4,5x80 | 188 | 012620009 |
| 2x6x100 | 219 | 012620018 |

1263/D8

1260 ⬤ 0,4x2,5x50-0,5x3x75-0,8x4x100-1x5,5x125-1,2x6,5x150 mm
1262 ⊕ PH0x3x60-PH1x4,5x80-PH2x6x100 mm

600 g 📄 012630008



1260N

SCREWDRIVERS FOR SLOTTED HEAD SCREWS,
EXTRA-SHORT SERIES

ISO 2380

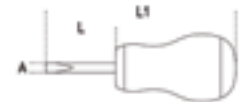

| SxAxL mm | L1 mm | 📄 |
|------------|-------|-----------|
| 0,8x4x30 | 87 | 012600103 |
| 1,2x6,5x30 | 87 | 012600106 |

1262N

SCREWDRIVERS FOR CROSS HEAD PHILLIPS®
SCREWS, EXTRA-SHORT SERIES

UNI/ISO 8764



| PHxDxL mm | L1 mm | 📄 |
|-----------|-------|-----------|
| 1x4,5x30 | 87 | 012620103 |
| 2x6x30 | 87 | 012620106 |

1266BP

BALL HEAD HEXAGON DRIVERS WITH HANDLES

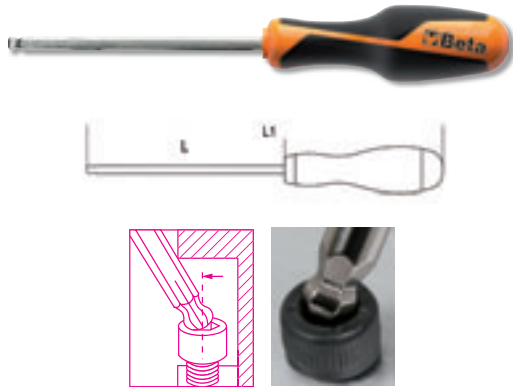

| mm | L mm | L1 mm | 📄 |
|-----|------|-------|-----------|
| 2 | 100 | 200 | 012660020 |
| 2,5 | 100 | 200 | 012660025 |
| 3 | 125 | 225 | 012660030 |
| 4 | 125 | 233 | 012660040 |
| 5 | 120 | 239 | 012660050 |
| 6 | 140 | 259 | 012660060 |
| 8 | 160 | 287 | 012660080 |
| 10 | 160 | 287 | 012660100 |

1266BP/S8

○ 2-2,5-3-4-5-6-8-10 mm

960 g 📄 012660308

1256/C36-2

BI-MATERIAL MICROSCREWDRIVER WITH 36 INTERCHANGEABLE 4-MM BITS AND MAGNETIC EXTENSION



| | | |
|--|---------|----------------------------------|
| | 1256TX | T3-T4-T5-T6-T7-T8-T9-T10-T15 |
| | 1256RTX | T6 - T7 - T8 - T9 - T10 |
| | 1256LP | 0,8-1,2-1,5-1,8-2-2,5-3-3,5-4 mm |
| | 1256PE | 0,7 - 0,9 - 1,3 - 1,5 - 2 mm |
| | 1256PH | PH000 - PH00 - PH0 - PH1 |
| | 1256PZ | PZ000 - PZ00 - PZ0 - PZ1 |
| | 1256/20 | |
| | 1256/30 | |

| mm | g | 📄 |
|-----------|-----|-----------|
| 130x60x35 | 200 | 012560100 |

1370

ENGINEER'S HAMMER, WOODEN SHAFT

UNI 7778 DIN 1041



| g | A mm | L mm | L1 mm | g | 📄 |
|-----|------|------|-------|-----|-----------|
| 200 | 19 | 280 | 95 | 236 | 013700052 |
| 300 | 23 | 300 | 105 | 439 | 013700053 |
| 500 | 27 | 320 | 118 | 669 | 013700055 |

1370T

MECHANIC'S HAMMERS FIBRE SHAFT



| g | A mm | L mm | L1 mm | g | 📄 |
|-----|------|------|-------|-----|-----------|
| 200 | 19 | 280 | 95 | 328 | 013700620 |
| 300 | 23 | 300 | 105 | 452 | 013700630 |
| 500 | 27 | 320 | 118 | 663 | 013700650 |

1390

SOFT FACE HAMMERS, WOODEN SHAFTS

UNI 7784



| Ø mm | L mm | L1 mm | g | 📄 |
|------|------|-------|-----|-----------|
| 22 | 260 | 70 | 134 | 013900022 |
| 28 | 280 | 85 | 230 | 013900028 |
| 35 | 310 | 95 | 365 | 013900035 |
| 45 | 320 | 107 | 698 | 013900045 |



1390R

spare faces for item 1390

| | | |
|---------|--|-----------|
| ∅ 22 mm | | 013900122 |
| ∅ 28 mm | | 013900128 |
| ∅ 35 mm | | 013900135 |
| ∅ 45 mm | | 013900145 |



1650

SLIDING GAUGE MADE FROM HARDENED STAINLESS STEEL IN LEATHER SHEATH

- Reading to 0.05 mm
- Spring locking
- UNI EN ISO 13385-1DIN 862

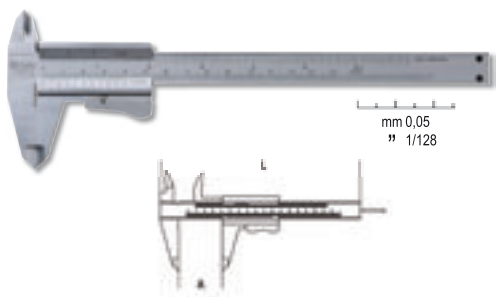

CE

| A max mm | L mm | |
|----------|------|-----------|
| 150 | 235 | 016500001 |

1651DGT

DIGITAL VERNIER MADE FROM HARDENED STAINLESS STEEL IN HARD PLASTIC CASE

- mm/inch conversion
- UNI EN ISO 13385-1DIN 862CE

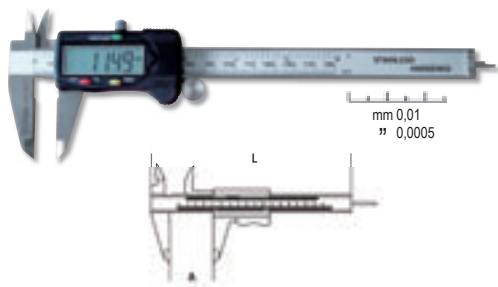

CE

| A max mm | L mm | |
|----------|------|-----------|
| 150 | 225 | 016510111 |

1692

MEASURING TAPES

- shock-resistant bi-material ABS casings, steel tapes, precision class II



CE

| | L m | S mm | |
|--------|-----|------|-----------|
| 1692/2 | 2 | 16 | 016920052 |
| 1692/3 | 3 | 16 | 016920053 |
| 1692/5 | 5 | 19 | 016920055 |

1695XS

POCKET SPIRIT LEVEL WITH MAGNETIC V-SHAPED BASE

- made from profiled aluminium
- 2 unbreakable vials accuracy: 1 mm/m
- ideal for pipes and round sections in general
- complete with clip



| L mm | H mm | S mm | |
|------|------|------|-----------|
| 70 | 48,5 | 20 | 016950250 |

1696

SPIRIT LEVELS MADE FROM ANODIZED PROFILE ALUMINIUM

- 2 unbreakable vials
- accuracy: 1 mm/m



| L mm | H mm | S mm | |
|------|------|------|-----------|
| 200 | 50 | 19 | 016960002 |

1696B

SPIRIT LEVELS WITH MAGNETIC BASES MADE FROM ANODIZED PROFILED ALUMINIUM

- 2 unbreakable vials
- accuracy: 1 mm/m



| L mm | H mm | S mm | |
|------|------|------|-----------|
| 200 | 49 | 22 | 016960202 |

1737NX

BRAKE SHOE CLEANING BRUSH
PLASTIC HANDLE STEEL WIRES



| L mm | |
|------|-----------|
| 270 | 017370010 |

1762

EVOLVING PUNCH PLIERS



| Ø mm | L mm | |
|-------------------|------|-----------|
| 2-2,5-3-3,5-4-4,5 | 210 | 017620001 |

1767PMC

MAGNETIC TOOL HOLDER, ROUND



| Ø mm | |
|------|-----------|
| 150 | 017670020 |

1719BMA...Q

SECOND-CUT SQUARE FILES, WITH HANDLES



| | L mm | L" mm | |
|------------|------|-------|-----------|
| 1719BMA6/Q | 150 | 6 | 017190021 |
| 1719BMA8/Q | 200 | 8 | 017190052 |

1719BMA...T

SECOND-CUT TRIANGULAR FILES,
WITH HANDLES



| | L mm | L" mm | |
|------------|------|-------|-----------|
| 1719BMA6/T | 150 | 6 | 017190023 |
| 1719BMA8/T | 200 | 8 | 017190054 |

1719BMA...P

SECOND-CUT FLAT FILES, WITH HANDLES



| | L mm | L" mm | |
|------------|------|-------|-----------|
| 1719BMA6/P | 150 | 6 | 017190025 |
| 1719BMA8/P | 200 | 8 | 017190056 |

1719BMA...M

SECOND-CUT HALF-ROUND FILES,
WITH HANDLES



| | L mm | L" mm | |
|------------|------|-------|-----------|
| 1719BMA6/M | 150 | 6 | 017190027 |
| 1719BMA8/M | 200 | 8 | 017190058 |

1719BMA...R

SECOND-CUT ROUND FILES, WITH HANDLES



| | L mm | L" mm | 📄 |
|------------|------|-------|-----------|
| 1719BMA6/R | 150 | 6 | 017190029 |
| 1719BMA8/R | 200 | 8 | 017190060 |

1719BMA6/S5

L 150 mm - ■▲▶●●

560 g 📄 017190030

1719BMA8/S5

L 200 mm - ■▲▶●●

870 g 📄 017190070

1771

UTILITY KNIFE, 18 MM

- supplied with 3 blades



| L mm | A mm | 📄 |
|------|------|-----------|
| 170 | 18 | 017710000 |

1772R

UTILITY KNIFE WITH RETRACTABLE TRAPEZOIDAL BLADE

- supplied with 5 blades
- interior blade storage
- belt clip
- sturdy aluminium frame



| L mm | A mm | 📄 |
|------|------|-----------|
| 125 | 18 | 017720006 |

1726

HACKSAW FRAME, BLADE ATTACHMENT SYSTEM IN THE HANDLE

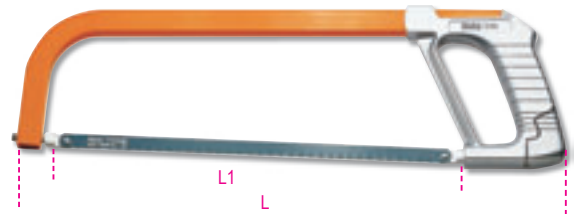

| L mm | L1 mm | 📄 |
|------|-------|-----------|
| 440 | 300 | 017260001 |

1728BM

blades for hacksaw frames - L 300 mm

18 g 📄 017280010



1599F

PARALLEL BENCH VICES

- with hardened top and slides

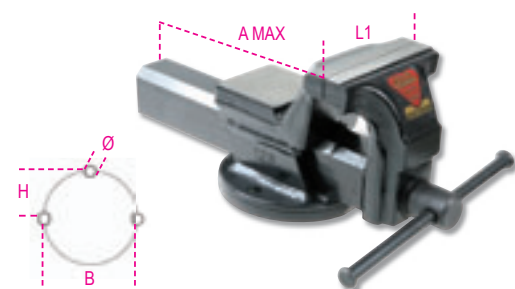

| L1 mm | BxH mm | Ø mm | A max mm | 📄 |
|-------|--------|------|----------|-----------|
| 100 | 92x46 | 11 | 125 | 015990100 |
| 125 | 108x54 | 13 | 150 | 015990125 |
| 150 | 125x62 | 13 | 200 | 015990150 |

1716A

ANGLED BIT FOR GENERAL USE

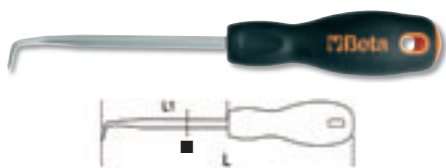

| L mm | L1 mm | ■ mm | |
|------|-------|------|-----------|
| 240 | 125 | 6 | 017160040 |

1716U

HOOK BIT FOR GENERAL USE

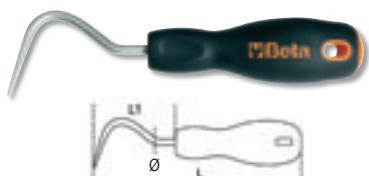

| L mm | L1 mm | Ø mm | |
|------|-------|------|-----------|
| 195 | 80 | 6 | 017160025 |

1716P

PACKING SCRAPER

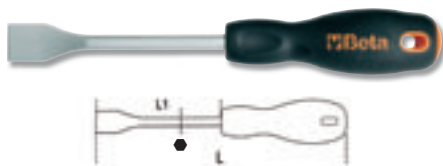

| L mm | L1 mm | ■ mm | |
|------|-------|------|-----------|
| 250 | 125 | 6 | 017160020 |

1716Q

SQUARE BIT REAMER

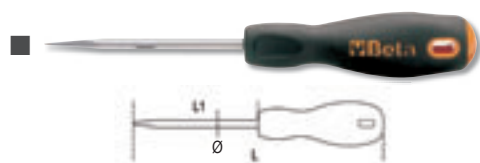

| L mm | L1 mm | Ø mm | |
|------|-------|------|-----------|
| 215 | 100 | 6 | 017160010 |

1716R

ROUND BIT REAMER

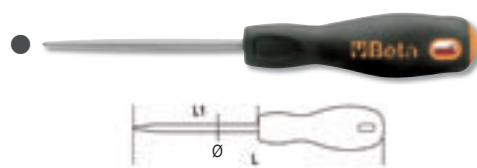

| L mm | L1 mm | Ø mm | |
|------|-------|------|-----------|
| 215 | 100 | 6 | 017160001 |



1838FLASH

RECHARGEABLE, ULTRACOMPACT SPOTLIGHT

- Designed to offer the best possible solution for each use
- IP65 - without external power supply-
- Dual brightness: 720 / 360 lumens
- Lithium polymer battery 7.4 V 4000 mAh
- Life 4-7 hours (depending on brightness)
- 12V cigarette lighter or 230V plug socket charger, it also allows operation with a completely flat battery
- 12V rubber bayonet connector
- Recharge/on-off cable, 5 m long
- White light, 4500 °K



CE

| 1838FLASH | IP65 | 018380300 | |
|-----------|------|-----------|--|

1838COB

COMPACT RECHARGEABLE INSPECTION LAMP WITH ULTRA-BRIGHTNESS LEDS

- Lithium polymer battery
- Compact body made of antislip rubber
- Swinging hook
- Magnetic base can be rotated 180 degrees
- With charger 100-240Vac / 50-60Hz
- 100/200 lumens; SPOT 75 lumens
- Operating range: 6h / 3h; SPOT 4h



CE

| | | |
|---------|------|-----------|
| 1838COB | IP65 | 018380010 |
|---------|------|-----------|

1838/11LED

RECHARGEABLE INSPECTION LAMP WITH ULTRA-HIGH BRIGHTNESS LEDS

- Lithium polymer battery
- Compact body made of antislip rubber
- Easy-to-replace front glass
- Swinging hook
- With charging station, 110-230Vac
- 320 lumens
- With multidirectional head LED



CE

| | | |
|------------|------|-----------|
| 1838/11LED | IP65 | 018380111 |
|------------|------|-----------|

1895

ULTRASONIC CLEANING TANK

- With special degas function
- Ultrasonic cleaning relies on fluid heating to effectively clean spare parts and metal pieces in general (carburetors, valves etc.)
- Digital display for temperature and cleaning time selection
- Two cleaning modes: "soft" and "normal"
- For normal cleaning, just use water at a temperature of 50/60 °C
- For more accurate cleaning, add non-foaming detergent solutions specific for ultrasonic tanks
- Using the degas mode speeds up air release throughout the tank, thereby improving ultrasonic cleaning efficiency



| | | | |
|---------------------|--------------------|--------------------|--------------------|
| Tank capacity | 6 litri | 13 litri | 27 litri |
| Drain tap | ✓ | ✓ | ✓ |
| Power | 150 Watt | 300 Watt | 500 Watt |
| Heating power | 300 Watt | 400 Watt | 500 Watt |
| Temperature range | 0÷80°C | 0÷80°C | 0÷80°C |
| Cleaning time range | 0-99 min | 0-99 min | 0-99 min |
| Frequency | 40 kHz | 40 kHz | 40 kHz |
| Power supply | 220/230V | 220/230V | 220/230V |
| Dimensions | 330x180 x310 mm | 350x325 x320 mm | 530x330 x380 mm |
| Tank dimensions | 300x155 x150 mm | 325x235 x145 mm | 500x300 x200 mm |

CE

| | | | |
|---------|----|------|-----------|
| | l | kg | |
| 1895 6 | 6 | 8,1 | 018950060 |
| 1895 13 | 13 | 12,5 | 018950130 |
| 1895 27 | 27 | 13,5 | 018950270 |

2250-0

HEAVY DUTY SWIVEL CREEPER SEAT WITH TRAY

- Round swivel seat
- Height can be adjusted through a gas piston mechanism (410-530 mm)
- 2 tote/tool trays, one being vertically adjustable
- 5 pivoting castors



| H mm | kg | Barcode |
|-----------|----|-----------|
| 410 ÷ 530 | 6 | 022500011 |



Oliviero Troia, Fernando Gaviria



**CONTAINERS
AND
ASSORTMENTS**



2028/VV

TOOL CASE, MADE OF POLYPROPYLENE,
EMPTY

- 2 tool panels
- Interior bottom with removable partitions
- Double combination lock



| mm | kg | |
|-------------|-----|-----------|
| 470x410x185 | 4,9 | 020280010 |

2029/VV

TOOL CASE, MADE OF THICK POLYPROPYLENE,
ALUMINIUM EDGED, EMPTY

- 2 interior tool panels



| mm | kg | |
|-------------|-----|-----------|
| 490x380x230 | 6,1 | 020290000 |

C13

TOOL TRUNK WITH CASTORS,
MADE OF STURDY POLYPROPYLENE



| mm | kg | |
|-------------|-----|-----------|
| 870x410x350 | 7,2 | 021130000 |

CP17

TOOL BOX, MADE OF STAINLESS STEEL
AND PLASTIC, REMOVABLE TOTE-TRAY



| mm | kg | |
|-------------|-----|-----------|
| 500x200x220 | 2,5 | 021170500 |

C20L

FIVE-SECTION CANTILEVER TOOL BOX,
MADE FROM SHEET METAL



| mm | kg | |
|-------------|-----|-----------|
| 550x200x210 | 5,4 | 021200002 |



C41H

TWO-MODULE TOOL TROLLEY

- Sheet metal frame and plastic tops, synonymous with remarkable sturdiness and reduced weight.
- 2 detachable modules:
 - 1 upper tool box,
 - 1 module with 2 drawers 95 mm in height, 1 pull-out case made of plastic, 66 mm high, and 1 drawer 295 mm in height.
- Oversized castors (160 mm), built into frame for easy transport - for example, on steps.
- Side centralized lock for closing drawers of lower module.
- Drawers with ball bearing slides and double closing hook.
- Telescopic aluminium handle.
- Small tool holder built into upper tool box.
- Lower drawer with double ballbearing slide.



| | RAL | kg | 041000002 |
|--------|------|----|-----------|
| C41H-O | 2011 | 21 | 041000002 |
| C41H-N | 9005 | 21 | 041000005 |
| C41H-B | 5002 | 21 | 041000006 |
| C41H-R | 3000 | 21 | 041000008 |
| C41H-G | 7016 | 21 | 041000010 |
| C41H-Y | 1023 | 21 | 041000012 |
| C41H-W | 9016 | 21 | 041000021 |
| C41H-V | 6016 | 21 | 041000024 |

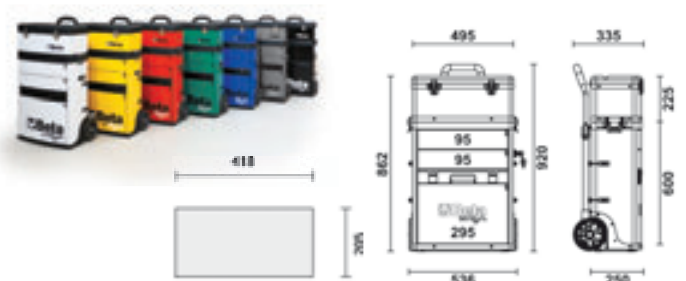

C41S

TWO-MODULE TOOL TROLLEY

- Sheet metal frame and plastic tops, synonymous with remarkable sturdiness and reduced weight.
- 2 detachable modules:
 - 1 upper tool box,
 - 1 module with 2 drawers, 95 mm and 295 mm high respectively.
- Oversized castors (160 mm), built into frame for easy transport - for example, on steps.
- Side centralized lock for closing drawers of lower module.
- Drawers with ball bearing slides and double closing hook.
- Telescopic aluminium handle.
- Small tool holder built into upper tool box.
- Lower drawer with double ballbearing slide.



| kg | 041000001 |
|----|-----------|
| 16 | 041000001 |

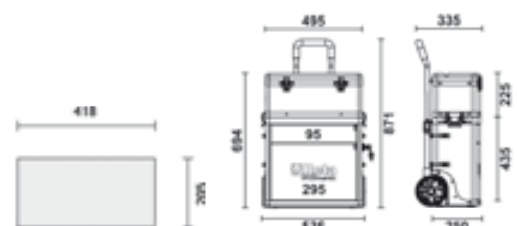

C24S

MOBILE ROLLER CAB

- Drawers (588x367 mm) with ball bearing slides.
- Drawer bases protected by foamed rubber mats.
- Four castors 125 mm in Ø:
2 fixed and 2 steering (one with brake).
- Front centralized safety lock.
- Static load capacity: 800 kg.
- Thermoplastic worktop designed to match tool chests C22S, C23S, C23SC and C23ST
- Integrated side bottle holder.
- Paper roll holder item 2400S-R/PC can also be included.



| | h | max | |
|--------|---|--------|-------|
| C24S/5 | 2 | 70 mm | 25 kg |
| | 2 | 140 mm | 30 kg |
| | 1 | 280 mm | 35 kg |
| C24S/6 | 4 | 70 mm | 25 kg |
| | 1 | 140 mm | 30 kg |
| | 1 | 280 mm | 35 kg |
| C24S/7 | 5 | 70 mm | 25 kg |
| | 1 | 140 mm | 30 kg |
| | 1 | 210 mm | 30 kg |
| C24S/8 | 6 | 70 mm | 25 kg |
| | 2 | 140 mm | 30 kg |

| | Ral 2011 ● | Ral 7016 ● | Ral 3000 ● | kg |
|--------|------------|------------|------------|----|
| C24S/5 | 024002051 | 024002052 | 024002053 | 52 |
| C24S/6 | 024002061 | 024002062 | 024002063 | 55 |
| C24S/7 | 024002071 | 024002072 | 024002073 | 58 |
| C24S/8 | 024002081 | 024002082 | 024002083 | 61 |

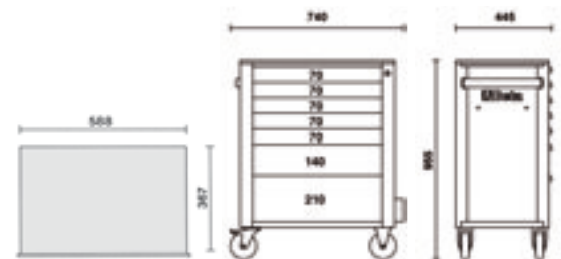

C24SL

MOBILE ROLLER CAB WITH SEVEN DRAWERS AND SIDE TOPS

- Seven drawers (588x367 mm) with ball bearing slides:
5 drawers, 70 mm high
1 drawer, 140 mm high
1 drawer, 210 mm high.
- Drawer bases protected by foamed rubber mats.
- Four castors 125 mm in Ø:
2 fixed and 2 steering (two with brakes).
- Front centralized safety lock.
- Static load capacity: 1.100 kg.
- Multi-ply wood worktop with holes for a vice (1599F/100, to be ordered separately).
- Side compartment with vertically adjustable top.
- Integrated paper roll holder.
- Double rear bottle holder.

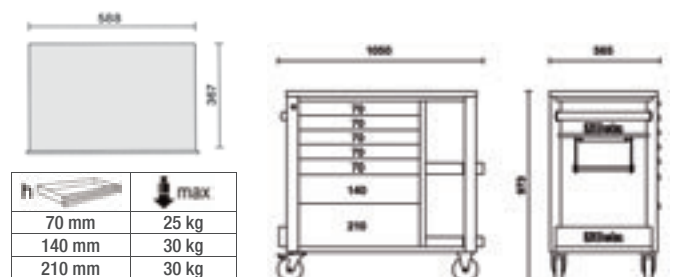

| | kg | |
|---------|----|-----------|
| C24SL-O | 80 | 024002101 |
| C24SL-G | 80 | 024002102 |
| C24SL-R | 80 | 024002103 |

C57SA

MASTERCARGO WORKBENCH

- Model with tool storage board (C57P) and one drawer cabinet.
- Drawer cabinet: five drawers, 588x367 mm, 390 mm high, 1180 mm and 1280 mm high, with ball bearing slides.
- Can accommodate thermoformed trays.
- Centralized lock.
- Panel tool holder with holes on back for wall mounting.
- Vertically operated aluminium shutter, with lock.
- Three removable perforated panels for supporting tools.
- Multi-ply worktop, coated in plastic laminate with three holes for vice item 1599F/150, to be ordered separately.



| | kg | |
|----------|-----|-----------|
| C57S/A-0 | 205 | 057001005 |
| C57S/A-G | 205 | 057001205 |
| C57S/A-R | 205 | 057001405 |

| h | max |
|--------|-------|
| 90 mm | 30 kg |
| 180 mm | 40 kg |
| 280 mm | 40 kg |

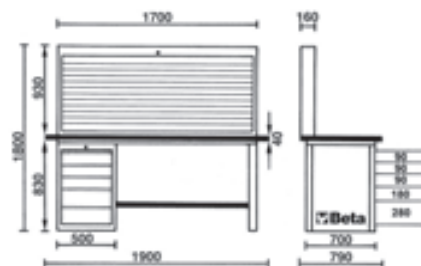

C57SB

MASTERCARGO WORKBENCH

- Model with tool storage board (C57P) and two drawer cabinets.
- Drawer cabinet: five drawers, 588x367 mm, 390 mm high, 1180 mm and 1280 mm high, with ball bearing slides.
- Can accommodate thermoformed trays.
- Centralized lock.
- Panel tool holder with holes on back for wall mounting.
- Vertically operated aluminium shutter, with lock.
- Three removable perforated panels for supporting tools.
- Multi-ply worktop, coated in plastic laminate with three holes for vice item 1599F/150, to be ordered separately.



| | kg | |
|----------|-----|-----------|
| C57S/B-0 | 243 | 057001006 |
| C57S/B-G | 243 | 057001206 |
| C57S/B-R | 243 | 057001406 |

| h | max |
|--------|-------|
| 90 mm | 30 kg |
| 180 mm | 40 kg |
| 280 mm | 40 kg |

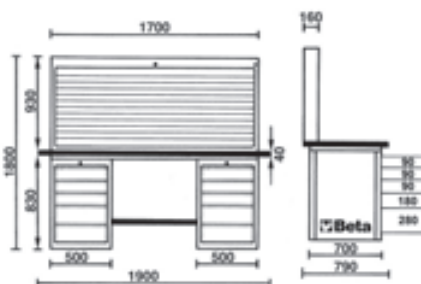

C57SP

PANEL TOOL HOLDER

- Panel tool holder with two holes on back for wall mounting.
- Aluminium shutter, vertically adjustable, with lock.
- Three removable perforated panels for tool holding.



| | kg | |
|---------|----|-----------|
| C57SP-0 | 46 | 057001020 |
| C57SP-G | 46 | 057001220 |
| C57SP-R | 46 | 057001420 |

5980U/BIKE

ASSORTMENT OF 90 TOOLS FOR BICYCLE REPAIRS

Assortment recommended in combination with CP17 - C20L



| Quantity/Description | Beta N. | Quantity/Description | Beta N. |
|---|-----------|---|------------|
| 9 combination wrenches 6-7-8-10-11-13-14-17-19 mm | 42 | 1 Slip joint pliers boxed joints 250 mm | 1048 |
| 9 ball head offset hexagon key wrenches ○ 1,5-2-2,5-3-4-5-6-8-10 mm | 96BPC/SC9 | 1 diagonal cutting nippers ∇ 160 mm | 1082 |
| 8 offset hexagon key wrenches 2-2,5-3-4-5-6-8-10 mm | 96T/S8 | 1 electrician's scissors, straight blades 145 mm | 1128BM |
| 8 drivers for Torx® head screws, with handles ⊕ T8-T10-T15-T20-T25-T27-T30-T40 | 97TTX/S8 | 1 half-round needle nose pliers \equiv 180 mm | 1150 |
| 1 adjustable wrenches with scales chrome-plated 200 mm | 111G | 1 screwdrivers for slotted head screws \bullet 160 mm | 1166 |
| 1 pipe cutter for copper and light alloy pipes | 334 | 7 3x75-4x125-5,5x150-6,5x150-PH0x60-PH1x80-PH2x100 mm | 1203/D7 |
| 1 click-type torque wrenches with reversible ratchets 2÷10 Nm | 605E | 1 engineer's hammer 300 g | 1370 |
| 13 ○ 4-4,5-5-5,5-6-7-8-9-10-11-12-13-14 mm | 900/SB13 | 1 soft face hammer \emptyset 35 mm | 1390 |
| 8 ○ 2,5-3-4-5-6-7-8-10 mm | 900ME/SB8 | 1 sliding gauge 150 mm | 1650 |
| 8 ⊕ T9-T10-T15-T20-T25-T27-T30-T40 | 900TX/SB8 | 1 measuring tape 3 m | 1692 |
| 1 1/4" drive extension bar | 900/21 | 1 second cut files 200 mm | 1719BMA8/P |
| 1 1/4" drive universal joint | 900/25 | 1 second cut files 200 mm | 1719BMA8/M |
| 1 1/4" reversible ratchet \oplus | 900/55 | 1 second cut files 200 mm | 1719BMA8/R |
| | | 1 hacksaw frame, aluminium handle 300 mm | 1725 |
| | | 1 snap - off blade utility knife 18 mm | 1771 |

| |
|-----------|
| 059800040 |
|-----------|

WORKSHOP EQUIPMENT C55

The modular workshop combination that allows you to create a modern work environment customized to fit your space and storage needs. Choose from a wide range of solutions sharing high quality standards, designed to make the most of your time by optimizing work.

QUALITY

Beta's best "Made in Italy" quality to furnish your workshop

ORGANIZATION

A rationally organized workbench system as synonymous with optimized work

MODULARITY

Modular workshop system, customized to fit your space and storage needs

DESIGN

Refined finish to make your workplace a neat, aesthetically captivating environment

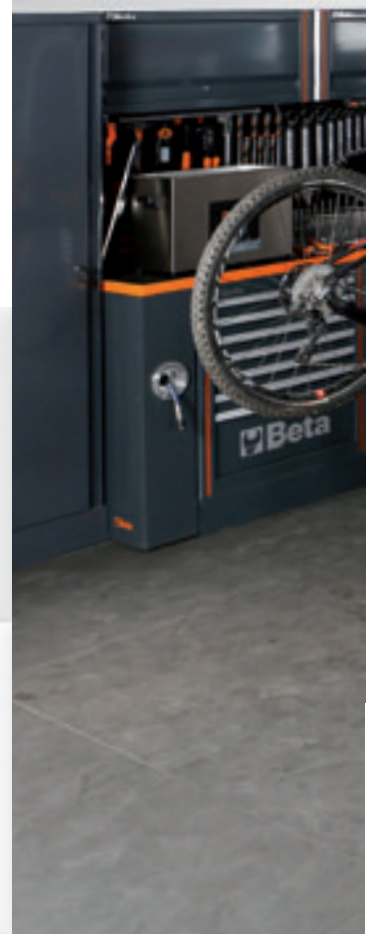

IMAGINE AND CREATE...

MADE IN ITALY



*Configure your workshop
in 3D online*

WWW.RSC55.COM



C55

COMPREHENSIVE WORKSHOP EQUIPMENT COMBINATION

Comprehensive combination comprising:

- Single-door tool cabinet (C55A1)
- Two-door tool cabinet (C55A2)
- Workbench (C55B0/2)
- Workbench with sockets (C55PRO B0/2)
- Mobile roller cab with 7 drawers (C55C7)
- Fixed module with 2 storage drawers (C55M2)
- Fixed module with 7 drawers (C55M7)
- Fixed service module (C55MS)
- Tool panel with suspended cabinets (C55/2PM)
- Tool panel with shutter (C55PS-0)

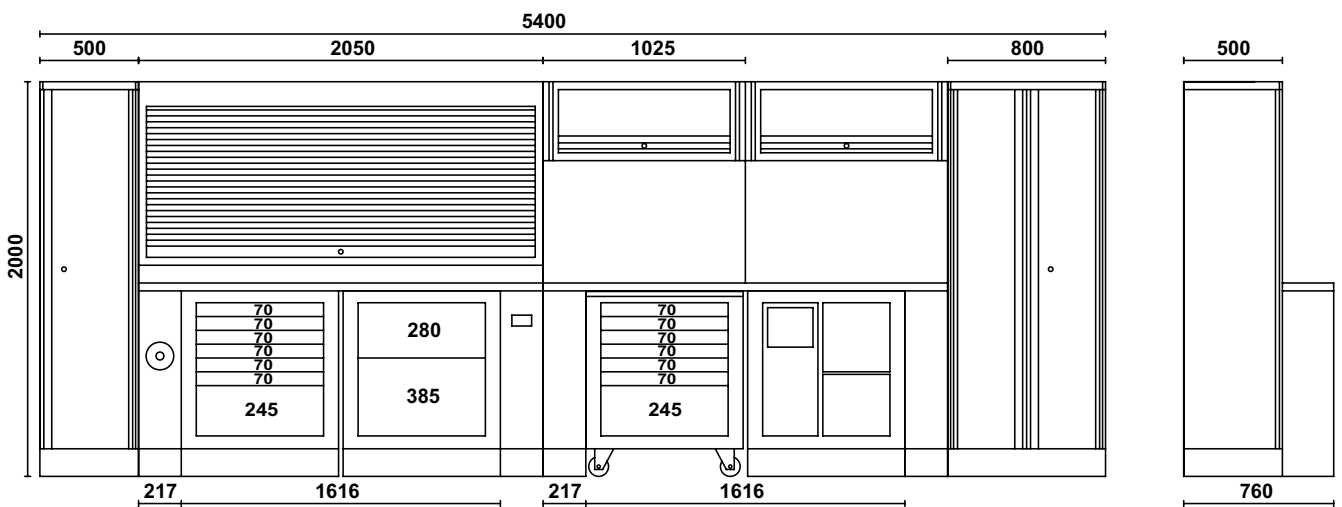

| | |
|-----|-----------|
| kg | |
| 801 | 055000000 |

Beta Collection







 **Beta**
www.beta-tools.com



The images are for reference only. Beta Utensili S.p.A. reserves the right to update and upgrade its product range without notice.

Beta Utensili S.p.A. | via Volta, 18 |
20845 Sovico (MB) | tel +39 039 20771 |